



# CENTRAL IOWA BROADBAND INTERNET STUDY

## STUDY PARTNERS



Adair County  
Board of  
Supervisors



Pella Cooperative Electric  
Your Touchstone Energy® Cooperative



Produced by

HR Green

In Partnership with

B & G Global

Smart Source

KAS

# EXECUTIVE SUMMARY

Broadband has become a significant component of the quality of life of most people in the United States and world. Now referred to as the Fourth Utility, broadband is as important to economic development as access to water, sewer, electricity and transportation infrastructure. The recent COVID-19 pandemic has brought into sharp focus the reality that access to advanced broadband has become not just a nicety for video streaming and social media, but an integral part of how Central Iowans learn, work and receive medical care.

The Central Iowa Broadband Internet Study was initiated in early 2021 with a goal to create a framework under which governments, the public and providers can align in new and innovative ways to create solutions to the digital divide present in Central Iowa.

The study confirmed the suspected presence of a bifurcation in the region. Issues of accessibility, affordability and digital literacy exist across the region. In many of the urban and suburban areas, homes and businesses have good access to broadband services that meet the State's new definition of acceptable broadband. In rural and remote areas, provider options are often more limited, with speeds that are frequently not adequate to fully participate in the communication applications that enable children to participate in distance learning, companies and workers to effectively work remotely and sick individuals or families to receive access to telemedicine. Additionally, broadband adoption has lagged in some urban areas due to adoption challenges such as cost of service for lower-income residents.

Efforts to close the broadband gap have the potential to create significant economic benefits for the region. There is an opportunity to improve broadband access and increase adoption by up to **19% of households** (or approximately 181,500 people), which would create estimated 20-year net

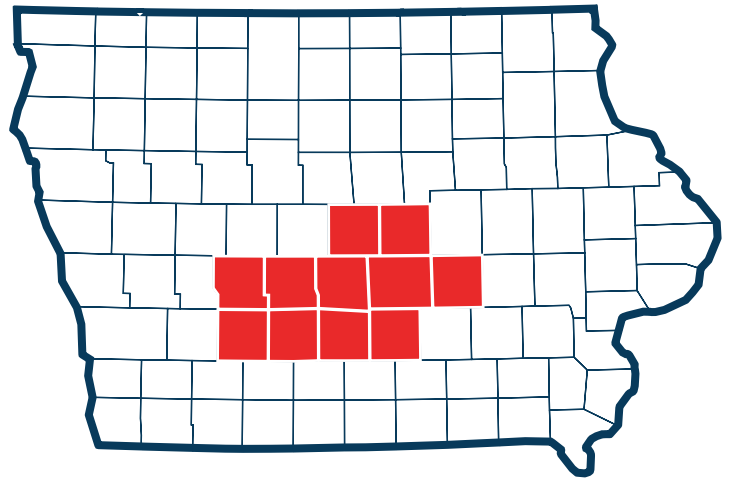

## COUNTY PARTICIPANTS

Adair County, Dallas County, Guthrie County, Jasper County, Madison County, Marion County, Marshall County, Polk County, Poweshiek County, Story County, and Warren County.

present value of **\$1.25 billion to the Greater Des Moines region** (i.e., the current value of the 20-year projection). This shows clearly how improvements can drive not just quality of life but create tangible economic impacts in Central Iowa.

**The key findings of this study are summarized in this Executive Summary and documented more thoroughly in the following report ([centraliowabroadbandsurvey.com](http://centraliowabroadbandsurvey.com)) and in future Greater Des Moines Partnership resources.**

***There are real opportunities in the region to take positive steps forward to create this new, more inclusive future.***

*This document contains a number of technical terms. A full glossary of common broadband terminology can be found in **Appendix A**.*

## KEY FINDINGS

### THE DIGITAL DIVIDE IS REAL IN CENTRAL IOWA

More than 4,500 residents and businesses participated in the Central Iowa Broadband Internet Study survey. The study included a speed test, and those results show a real divide between urban/suburban and rural/remote areas of Central Iowa. In aggregate, and somewhat surprisingly, more than 40% of homes reported download speeds of less than 25 Megabits per second (Mbps), which not only are insufficient for the advanced communication uses now required, but do not meet even the FCC's definition of high-speed broadband.

*There are a number of interesting findings related to available broadband services in the 11-county region:*

- **The median speeds in urban/suburban communities were approximately three times higher than rural/remote speeds**
- **Overall, 42.6% of download speeds tested were lower than the FCC broadband definition of 25 Mbps**
  - Among rural speed tests, 64.0% were lower than 25 Mbps
  - Among town/city speed tests, 32.2% were lower than 25 Mbps
- **Overall, 31.5% of upload speeds tested were lower than the FCC broadband definition of 3 Mbps**
  - Among rural speed tests, 64.0% were lower than 3 Mbps
  - Among town/city speed tests, 32.1% were lower than 3 Mbps

### NEW GRANT PROGRAMS SHOULD DRIVE DEPLOYMENT OF BROADBAND IMPROVING TECHNOLOGIES

Broadband grant programs from the State and Federal levels will offer a once-in-a-lifetime opportunity to create economically sustainable models to deploy broadband improving technologies in the region's underserved rural and remote areas for the region's providers.

*The willingness of regional providers to access these funds is crucial to solving the current gaps in the market.*



#### FEDERAL

**The Federal government** is providing either broadband specific grants or funds that can be used for broadband. Examples of these are the American Rescue Plan Act, funding which was given to states, counties and cities for their determination of use, the United States Treasury Capital Improvement Fund (which will be provided to states) and the infrastructure plans that are working their way through Congress as of the time of this report.



#### STATE

**The State of Iowa** has announced its goal to provide \$450 million in broadband grants to rural and remote Targeted Service Areas between 2021 and 2024. The State of Iowa provided \$98 million in grants through Notice of Funding (NOFA) #6. Providers in Central Iowa received \$7.4 million in funding in this round (this number can be found in the Provider Engagement Section on page 62). The State opened NOFA #7 on October 25, 2021, which includes \$200 million in grant funding.

## BROADBAND IS CRUCIAL TO HOW CENTRAL IOWANS LEARN, WORK AND STAY HEALTHY

According to the Fiber Broadband Association (FBA), residential demand for both upstream and downstream bandwidth has been growing at a rate of 20-25% annually for over two decades. The FBA projects that peak demand for a family of four should exceed 400 Mbps symmetric in roughly seven years, with bandwidth needs accelerating in the years after that. For more information on broadband growth, see page 89.

This study occurred during the COVID-19 pandemic, which has highlighted broadband's crucial role driving the adoption of new technologies. During meetings with educators, health officials, government leadership and business leaders, it is now apparent that broadband adoption is not just a nicety but is crucial to participate in the pandemic and post-pandemic world.

- **Education:** Interviews with representatives from the education community in Central Iowa identified bandwidth limitations as the largest impediment to learning (particularly in adjusting to the pandemic). For more information on insights from educators, [see page 47](#).
- **Workplace:** Comments from meetings with representative businesses in Central Iowa, confirmed that the internet is essential for the operation of a business. These stakeholders unanimously agreed the internet should be treated as a utility. Reliability was a major concern voiced when referencing the current levels of private service. For greater detail from the discussions with these businesses, [refer to page 41](#).
- **Telemedicine:** Health care providers felt technology and connection limitations have been an impediment to the success of telehealth in some client situations. For other insights from the health care community regarding telehealth, [refer to page 45](#).

---

## PROVIDERS FACE BARRIERS BUT SUPPORT EXPANDING SERVICE

Three provider meetings were held throughout the study phase and meetings were well attended (averaging 20 to 25 people per meeting). Many expressed a strong interest in expanding their networks to solve the divide, but the economics of deploying to rural and remote areas have been a historic barrier.

---

## SOLVING THE DIVIDE HAS DRAMATIC ECONOMIC BENEFIT TO CENTRAL IOWA

As mentioned previously, but to underscore the potential impact, analysis of the survey data showed significant potential economic benefit of reaching those who are underserved.

- **\$1,300 annual household benefits**
- **Ag-sector benefits of \$12,000 per operation**
- **If 19% of households (or approximately 181,500 people) see improvement, there is an estimated 20-year NPV of \$1.25 billion to the Greater Des Moines region.**

## RECOMMENDATIONS

### ESTABLISH A SPONSOR TO IMPROVE COORDINATION AND FACILITATION

The Greater Des Moines Partnership (The Partnership) has played an important leadership role in improving broadband by initiating this study and intends to continue to provide resources to track regional progress. Additionally, it is crucial a sponsoring organization be identified to tackle important work of executing this plan's recommendations. Feedback from public and private sector representatives has shown the need for an ongoing, sponsoring entity or entities to coordinate and facilitate broadband improvement.

*Examples of those steps are:*

- **Regional Collaboration:** Economies of scale and middle mile transport can reduce costs of projects (and possibly make grant applications more viable) which requires a regional perspective. An entity that can continue to define the right people to work on those topics and to convene those discussions could have an impact.
- **Grant Support:** Grant programs can be a substantial administrative burden for many of the small providers in the region. With focused State and Federal grant preparation, significant dollars could be brought to Central Iowa that could transform broadband. The Des Moines Metropolitan Planning Organization (MPO) could be a resource to coordinate applications for State and Federal funding.
- **Financing:** Even with grant funding availability, providers will need access to private capital to meet matching grant requirements. Having a group who can bring projects and financial resources together can be a significant enabler of expansion in the region.

In addition to this study data and report, the State Office of the Chief Information Officer (OCIO) also developed a resource for more information. They engaged a private company, Fiber Utilities Group, to offer basic education and help in establishing next steps. As of October 2021, it is still being developed, but could be helpful.

While the OCIO resources may be useful, this assistance is intentionally limited in scope. Without a coordinated effort, it is possible that the resources provided through this study may not be enough to realize the full benefits of the potential regional broadband improvements.

---

### GOVERNMENTS SHOULD ADOPT PROGRESSIVE BROADBAND POLICIES

Counties and cities can help broadband improvement through their policies. A county's or city's policies can either help encourage broadband or discourage providers from investing in extending their networks. Providers consistently indicate a desire to deploy infrastructure in geographies where public sector administrators have adopted facilitative policies.

County or city policies help a provider stretch investment dollars and hasten speed to market, providers will be more likely to deploy broadband assets in those communities. Conversely, if policies and permitting processes increase the costs of broadband and slow the implementation, providers will likely build in other areas.

A prototype Colocation Policy was developed after consultation with governments and private sector providers and is attached as Appendix B of this report. We recommend the adoption of this policy by participants in the Central Iowa Broadband Internet Study as a way to encourage partnerships with the private sector to facilitate improvements in the region.

The Recommended Practices section (starting on Page 136) also provides recommendations related to the administration and coordination of resources in partnership with the private sector. Public entities should consider carefully how they facilitate these partnerships and have key levers which can enable more deployment in their geographies, such as:

- **Pursuing grants** (helping in grant writing, providing letters of support, etc.)
- **Working on investment that can stretch provider deployment dollars** (ARPA funds, grant matching funds, placing conduit, middle mile, etc.)
- **Other policies that can make deployment faster and less expensive**

---

## IMPROVE REGIONAL SUCCESS WITH BROADBAND GRANT FUNDING

In the first round of the State's new grant funding program, Central Iowa providers received just 7.6% of the total funding amount. This represents an almost \$3.4 million underperformance based on the number of counties in Iowa and a population-based pro-rata share of the available NOFA #6 funding total. It is crucial the region receive at least a proportional share of grant funding to remain competitive in the market.

Counties and private sector partners must be more aggressive in their pursuit of State and Federal funding as many areas are not economically viable for new buildouts without grant support.

---

## CREATE DIGITAL ADOPTION STRATEGIES

While much of the study focuses on the execution of strategies intended to provide access to better broadband technologies, it is critical to also develop effective adoption strategies for lower-income and socioeconomically disadvantaged communities in the 11-county region.

Despite the increased importance of broadband, cost continues to remain a barrier to broadband adoption. Only 18.5% of Iowa's population has access to a low-priced internet plan costing \$60 or less per month. These will be discussed in greater detail in this report, but there are agencies that can provide great insight and connection with those struggling with adoption whether those reasons are because of income, language barriers, difficulty with technology, etc. Also, there are communities like the City of West Des Moines that have organized a system to help connect those with financial need with the Federal government program that helps offset broadband costs.

---

## IMPLEMENT A REGIONAL BROADBAND DASHBOARD

In order to facilitate deployment, a beta-site broadband dashboard was created. This dashboard houses many of the results of this study and, importantly, will provide a data resource for providers considering the pursuit of grant funding to deploy next-generation technologies. It is our recommendation that The Partnership, or another sponsoring regional agency, maintain this data as a long-term resource to align with future grant programs and to track progress of the region toward its goals. Data included in this Dashboard includes:

- **Satisfaction and speed test results from the survey portion of the Central Iowa Broadband Internet Study**
- **Cost of deployment data**
  - *The technology study includes a projected build cost by Census block based on a combination of fiber and fixed wireless deployment.*
- **Integration with OCIO data**
  - *The dashboard should integrate with OCIO to reflect current programs and their impact on financial viability of potential projects.*

# SUMMARY

This Central Iowa Broadband Internet Study is intended to provide a launching point through which key stakeholders in the region have access to detailed analysis of the current broadband situation in the Central Iowa. More importantly, the study is intended to equip residents, government officials, funders and the private sector provider community with clear, actionable information with which to move forward. Solving the digital divide issues in Central Iowa will drive significant economic, quality of life, learning and medical service benefits that will position the area for long-term success and viability in the 21st century.

Two tools have been developed as part of the study to meet The Partnership's goal to create a more effective and efficient broadband dashboard. These deliverables help to define, inform and coordinate efforts to improve broadband in the 11-counties in the form of Recommended Practices and Technology Plans.

---

## RECOMMENDED PRACTICES

In the Recommended Practices section (starting on page 136), there are four categories, one for each key stakeholder group. These Recommended Practices provide step-by-step guidance that each entity can leverage to improve broadband.

*The four categories are:*

- Public sector
- Providers
- Financing entities
- Organizations focused on working with those who are facing difficulties accessing available broadband services

## TECHNOLOGY PLANS

Each county has been analyzed to develop a technology plan to show the most cost-effective technology deployment methodology. The models were developed to deploy higher-speed technologies in areas with density, where it will make fiber and DOCSIS coaxial deployments financially viable to create wired connectivity. In rural and remote areas, technologies like point-to-point wireless are more financially appropriate. These layouts show options based on density with their high-level cost at a Census block level, enabling private and public sector providers with important information that can be utilized to evaluate the financial feasibility of potential expansion projects.

Grants can change the math to make more rural areas more affordable. These technology plans also contain key information that is required in grant applications such as farm counts, public safety and school location, etc. While the costs of deployment have been developed without grant funding, the information being made available will also enable providers to quickly identify areas where grants can improve the economics of deployment and fuel more rapid expansion of service by reducing initial deployment costs.

**There is a very real opportunity for Central Iowans to realize the stated benefits of improved broadband in the region. Federal and State government have recognized the necessity of investing in improved broadband as a national priority. *This plan, and its accompanying deliverables, positions the region to move forward aggressively with that expansion, enabling Central Iowa's place as a continuing leader.***

# Table of Contents

<b>Background, Process and Methodology .....</b>	<b>10</b>
<b>Data Gathering and Analysis .....</b>	<b>12</b>
<b>GIS Base Map .....</b>	<b>12</b>
<b>Survey.....</b>	<b>12</b>
<b>Survey Results.....</b>	<b>14</b>
<b>Executive Summary of Survey Analysis .....</b>	<b>14</b>
<b>Median and Average Speeds .....</b>	<b>25</b>
<b>Advertised Speeds Compared to Recorded Speeds.....</b>	<b>26</b>
<b>Broadband Technology .....</b>	<b>28</b>
<b>Defining Broadband Service Areas.....</b>	<b>29</b>
<b>Urban .....</b>	<b>29</b>
<b>Suburban (Including Towns) .....</b>	<b>29</b>
<b>Rural (Unincorporated Areas) .....</b>	<b>30</b>
<b>Remote .....</b>	<b>30</b>
<b>Evaluating Current and Emerging Broadband Technologies.....</b>	<b>31</b>
<b>Fiber to the Premises (FTTP) .....</b>	<b>32</b>
<b>Coaxial Cable (DOCSIS 3.0/3.1) .....</b>	<b>33</b>
<b>Digital Subscriber Link (DSL) .....</b>	<b>33</b>
<b>Fixed Wireless .....</b>	<b>34</b>
<b>Satellite Broadband – Geostationary Earth Orbit .....</b>	<b>34</b>
<b>Satellite Broadband – Low Earth Orbit .....</b>	<b>35</b>
<b>Cellular Broadband .....</b>	<b>36</b>
<b>Technology Options Criteria Evaluation .....</b>	<b>36</b>
<b>Matching Technologies to Geography .....</b>	<b>36</b>
<b>Stakeholder Meetings .....</b>	<b>38</b>
<b>Public Sector Meeting .....</b>	<b>51</b>
<b>Public Engagement Topical Meetings .....</b>	<b>57</b>
<b>The Rural Broadband Experience.....</b>	<b>57</b>
<b>The Challenges of Learning From Home.....</b>	<b>58</b>
<b>Getting Care from Anywhere – Telehealth in Central Iowa .....</b>	<b>59</b>
<b>Remote Work Challenges and Opportunities.....</b>	<b>60</b>



<b>Provider Engagement.....</b>	<b>62</b>
<b>Identify Providers and Conduct Meetings.....</b>	<b>63</b>
<b>Grant Opportunities.....</b>	<b>69</b>
<b>Economic Benefits of Broadband Improvement .....</b>	<b>76</b>
<b>Executive Summary of Economic Benefits .....</b>	<b>76</b>
<b>Introduction of Economic Benefits of Improved Broadband .....</b>	<b>77</b>
<b>Methodology to Determine Economic Benefits of Improved Broadband .....</b>	<b>77</b>
<b>Adoption.....</b>	<b>78</b>
<b>Underserved Household Adoption .....</b>	<b>79</b>
<b>Economic Benefits.....</b>	<b>80</b>
<b>Broadband and Post-Pandemic Normal.....</b>	<b>93</b>
<b>Broadband and Post-Pandemic Normal Executive Summary .....</b>	<b>93</b>
<b>Current and Future Broadband Needs and Trends.....</b>	<b>94</b>
<b>Public Policy.....</b>	<b>120</b>
<b>Potential Risks of Strategic Broadband Approaches .....</b>	<b>124</b>
<b>Introduction to Risk Mitigation .....</b>	<b>124</b>
<b>Ongoing Measurement of Progress.....</b>	<b>133</b>
<b>Recommended Practices.....</b>	<b>136</b>
<b>Government Recommended Practices.....</b>	<b>136</b>
<b>Provider Recommended Practices.....</b>	<b>143</b>
<b>Financing Entities Recommended Practices .....</b>	<b>146</b>
<b>Consumer Adoption Advocacy Recommended Practices .....</b>	<b>150</b>
<b>Appendix A - Glossary of Terms .....</b>	<b>152</b>
<b>Appendix B – Colocation Policy.....</b>	<b>155</b>
<b>Appendix C – County Speed and Satisfaction Maps .....</b>	<b>157</b>
<b>Appendix D – Public Policy Whitepaper.....</b>	<b>168</b>
<b>Appendix E – Financing Options Whitepaper.....</b>	<b>177</b>
<b>Appendix F – Governors Broadband Whitepaper .....</b>	<b>181</b>

## Background, Process and Methodology

The broadband analysis for the 11-county region has followed the process in Figure 1 below. To guide the process, a Steering Committee was formed. The members of the Steering Committee were:

### Steering Committee Co-Chairs

Chris Costa	Knapp Properties, Inc.	Tej Dhawan	Principal Financial Group
-------------	------------------------	------------	---------------------------

### Steering Committee

Todd Ashby	Des Moines Area Metropolitan Planning Organization	Stacie LoVan	Greater Des Moines Partnership
Jerry Beyer	Vermeer Corporation	Debra Lucht	Minburn Communications
Robert Bledsoe	Des Moines Public Schools	David Maahs	Retired, Greater Des Moines Partnership
Todd Chapman	Central Iowa Satellite	Matt McCoy	Polk County Board of Supervisors
Mike Colwell	Retired, Greater Des Moines Partnership	Tanya Michener	Newton Development Corporation
Brian Crowe	Greater Des Moines Partnership	Linda Murken	Story County Board of Supervisors
Jeff Davidson	Jasper County Economic Development Corporation	Nancy Mwiroti	Pi515
Deidre DeJear	Caleo Enterprises	Bryan Nelson	OmniTel Communications
Mike Dickson	Guthrie County Board of Supervisors	John Norris	Polk County
Carla Eysink	Marion County Development Commission	Andrew Potter	Marshalltown Area Chamber of Commerce
Rachel Gocken	Warren County Economic Development Corporation	Scott Sanders	City of Des Moines
Leanne Harter	Story County	Amelia Schoeneman	Story County
Peter Johnson	Midwest Partnership Development Corporation	Courtney Shaw	Greater Des Moines Partnership
Scott Johnson	Aureon	Barry Smith	Knoxville Community School District
Michael Kacmarynski	PPI - Precision Pulley & Idler	Nick Sorensen	Ames Chamber and Economic Development
Rachael Kinnick	Grinnell Area Chamber of Commerce	Antoinette Stevens	Cisco Meraki
Tony Kioko	Principal Financial Group	Dave Stone	United Way of Central Iowa
Barb Kniff-McCulla	KLK Construction	Scott Tonderum	Greenfield Municipal Utilities
Tom Leners	Madison County Development Group	Jerry Walker	Adair County Board of Supervisors
Jamie Letzring	City of West Des Moines	Dan Warren	Des Moines Public Schools
Katie Lord	MidAmerican Energy Company		

Also, Work Groups were formed to execute different needs in the study. The Work Groups consisted of:

- Promotions – Created to promote the survey across the 11-counties
- Legislative and Grants – Created to evaluate and influence the legislative and grants processes.

During this study, the State of Iowa legislature began work on new legislation regarding broadband funding. This Work Group collaborated with the Partnership to inform study

participants of developments in this legislation and to, ultimately, work in influencing the language for the betterment of broadband in Iowa and for the grant opportunities in Central Iowa.

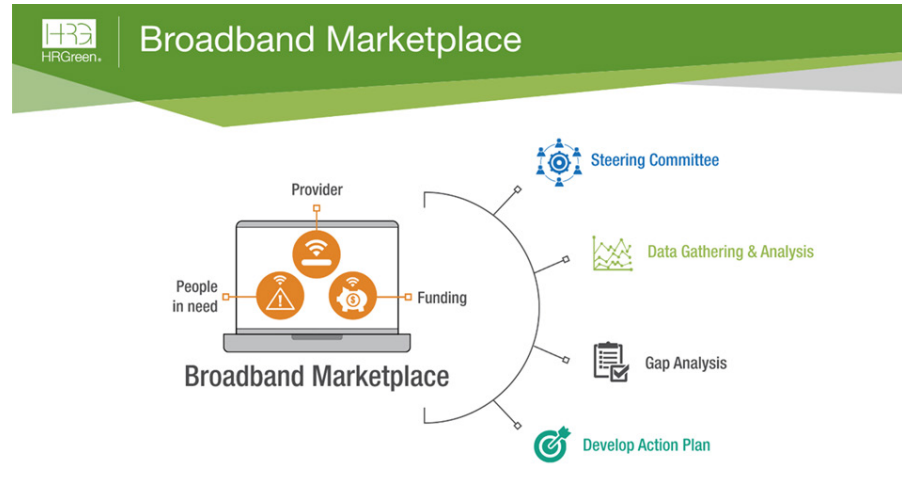

Figure 1 - The Broadband Marketplace Process

A significant goal in the overall study was to, as Steven Covey made famous, begin with the end in mind. The need for good data was clear from the initial development of the study. A process was put in place to develop a survey (including a speed test), promote the survey and record the results in GIS. Meetings with other stakeholders were also conducted along with a series of public topical meetings.

Rather than just collect information to study a problem, the end in mind was also how to use that data to take steps to improve broadband in Central Iowa. This concept, developed for this project, is the Broadband Marketplace.

The Broadband Marketplace is a three-legged stool. The first leg is based on the data (determination and understanding of the needs of lack of broadband access or adoption).

The second leg is the providers who would be expected to take most of the steps of either deploying infrastructure and/or extending their existing networks). Providers are not the only option and do not work in a vacuum, but they would likely be the ones to provide the vast majority of the broadband infrastructure.

The third leg is financing. Broadband improvement steps require capital. As will be shown later in this report, the needs for better broadband in Central Iowa are great enough that the amounts of capital needed can be sizeable.

There are multiple sources of funding for capital for broadband. Providers use sizeable amounts of their own funds to build networks. Those dollars can be for direct costs or used to provide matching funds for grant requirements. Another potential source of funding for broadband projects are grants. The State of Iowa has just released and awarded \$97 million in grants for broadband in NOFA #6. Some of that grant money will come to Central Iowa. At the time of completion of this study, the State released another \$200

million via NOFA #7. There will be more NOFAs from the State of Iowa for broadband. Also, the Federal government is allocating grant dollars through American Rescue Plan Act funds, US Treasury Capital Projects funds and infrastructure legislation funds. These grant dollars will be greater than any broadband programs in the past. Lastly, communities can provide funds through allocating ARPA or deploying infrastructure that can be used for improving broadband (conduit, towers, etc.).

Additionally, there are opportunities for other funding sources like bonding, banks and private capital invested to obtain a return that could be accessed.

Because of the order of magnitude of dollars needed for Central Iowa broadband improvements, all of these sources of funding can have significant impact on broadband in Central Iowa. A coordinated effort to bring these funding options to the table will likely determine the level of broadband improvement in a given area of the study.

Focusing on bringing these three legs of the Broadband Marketplace together is the power of beginning with the end in mind.

To move from data to taking steps in the Broadband Marketplace, each leg was developed in the course of this study. Then, action plans have been developed in the form of Recommended Practices, which are discussed later in this report.

## Data Gathering and Analysis

One of the key deliverables of this project is the data gathered from county GIS, a survey and stakeholder meetings.

### GIS Base Map

HR Green received GIS documents from all 11-counties and incorporated those into one map for the 11-county study area. This was important to be able to have a GIS based survey (that received results by location) and to develop a portal by which stakeholders could monitor progress during the survey.

### Survey

A significant deliverable in the Central Iowa Broadband Internet Study is a survey of all 11-counties. To undertake this scale of a survey, several steps were required.

- A. A Promotions Work Group was formed that consisted of representatives from each county. The members of this group were tasked with helping develop materials and utilizing those materials and the toolkit to reach people to take the survey
- B. Promotional materials were developed, including a promotions toolkit
- C. Distribution of a GIS-based survey

D. A survey review portal was established.

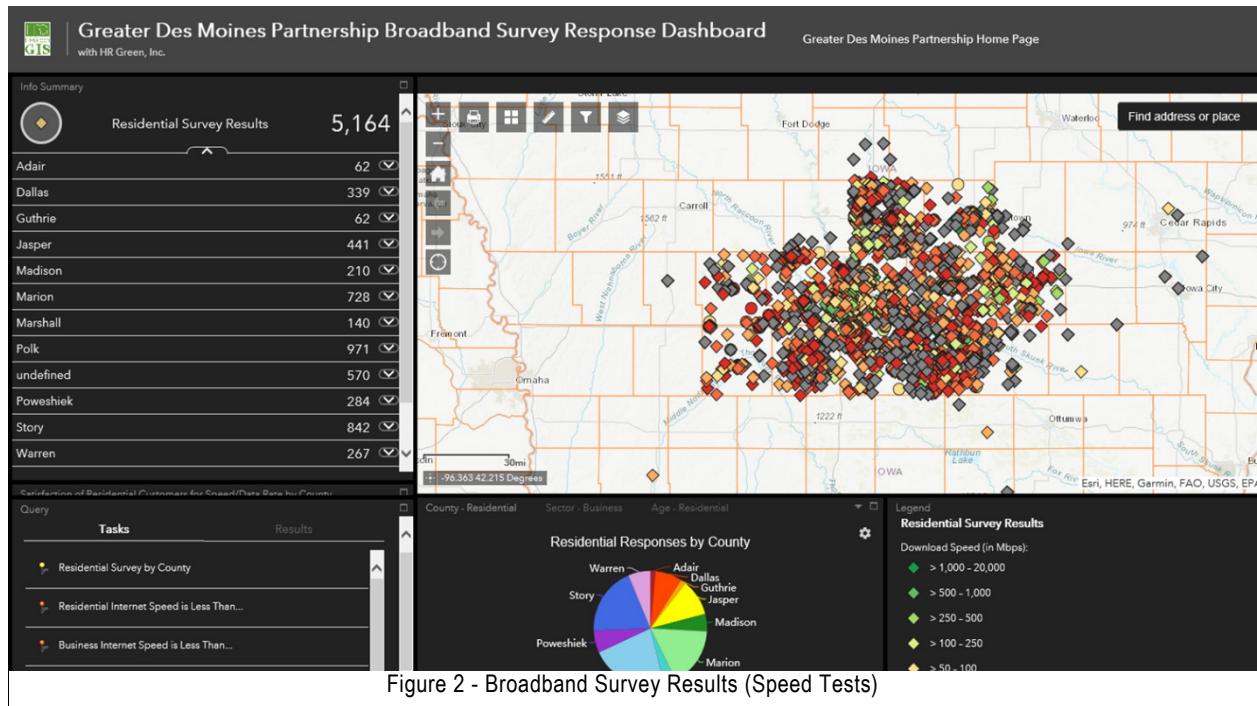

Figure 2 - Broadband Survey Results (Speed Tests)

# Survey Results

## Executive Summary of Survey Analysis

The survey portion of the Central Iowa Broadband Internet Study was conducted in the first half of 2021. Over 4,500 survey responses were recorded from residents and businesses in Adair, Dallas, Guthrie, Jasper, Madison, Marion, Marshall, Polk, Poweshiek, Story and Warren counties in Iowa (collectively, the Center Iowa Study Area [CISA]).

The survey produced a lot of data. Rather than just providing reams of paper related to the data that was collected, this report will focus on data directly related to some of the primary goals of the study:

- Identifying areas in the CISA without sufficient access to broadband internet
- Identifying who the internet adopters and non-adopters
- Identifying the reasons for non-adoption
- Identifying consumer attitudes among adopters related to their internet service.

Data collected by the survey and supported by the Iowa Office of Chief Information Officer (OCIO) broadband maps<sup>1</sup>, shows that a small but significant geographical area in the CISA does not have access to broadband (as defined by the U.S. Federal Communications Commission as 25 Megabits per second (Mbps) download speed and 3 Mbps upload speed). While 6.7% of survey respondents reported that no internet service was available at their home, the actual number of unserved homes is likely higher since persons without internet may not have been able to take the online survey.

90.4% of residential and survey respondents and 92.8% of business respondents say they subscribe to internet at their home or business. Adoption is significantly lower in rural areas, primarily due to lack of availability of a quality connection.

Among non-adopters – i.e., homes or businesses that do not have internet service - there are two main categories: those that are non-adopters by choice (service is available but they choose not to subscribe for various reasons) or forced non-adopters (no service is available at their location). Among the non-adopters by choice, the primary reason they don't subscribe is available services are too expensive. Non-adopters in cities appear to be more price sensitive to those in rural areas. While 62% of rural residents are willing to pay \$61 or more per month for internet if it were available, only 36% of town/city residents said the same. Other respondents reported that available internet was too slow to justify a subscription or too unreliable. Only a small percentage of non-adopters reported they didn't have a suitable device to connect to the internet or were concerned about privacy.

Among adopters, the speed tests taken as part of the survey revealed a clear split between the speeds being received by persons living in a town or city and those living in rural areas. The median download speed test among town/city respondents was three times higher than those

---

<sup>1</sup> Iowa Broadband Map version 4, Iowa OCIO.

<https://iowa.maps.arcgis.com/apps/webappviewer/index.html?id=3847e55ad45b4cecb88173d00d6108fe>

in rural areas. The gap was even greater among upload speeds measured, with the median town/city upload speed being six times that of rural respondents.

Being an adopter does not necessarily mean being satisfied with the connection you have. The Net Promoter Score (NPS) among all internet subscribers was -40 among city/town residents and -50.7 for rural residents. Since an NPS of 0 is considered average, this indicates that Central Iowans have a much lower than average level of satisfaction in their provider. The primary pain points reported were price, reliability, and customer service quality.

## **Introduction**

This survey section of the report will focus on what data was gathered from the Central Iowa Broadband Internet Study that will best provide direction or decision-makers, providers and citizens on the priorities moving forward, namely increasing access to reliable broadband networks and increasing adoption of broadband services.

## **Methodology**

The survey portion of the Central Iowa Broadband Internet Study was launched on March 24, 2021. Responses were collected over an eight-week period in March, April and May 2021. During the survey window, a total of 4,839 residential and 443 business responses were recorded.

Across the CISA, the responses represented a likely margin of error of less than 5% with a confidence level of 95%.<sup>2</sup> On a county-by-county level; however, only five counties (Dallas, Jasper, Marion, Polk and Story) had enough responses to reach a similar margin of error.

Surveys of this sort are susceptible to a certain amount of self-selection bias. In an ideal survey, a random sample of respondents is chosen from among the population. Due to the size and scope of the CISA, this was not possible. Since Central Iowans chose whether or not to participate in the study, there is a possibility the respondents may share certain characteristics with each other (such as access to internet) that non-respondents do not share. Indeed, a look at the overall demographics of the survey respondents indicates that certain population segments were overrepresented, and others were under representative. The results, while generally indicative of conditions and opinions in the CISA, may not represent an exact picture.

## **Survey Participant Demographics**

As mentioned above, a survey of this nature can lead to a certain amount of self-selection bias. Therefore, the goal was to capture a large enough sample that, even taking self-selection bias into account, we are left with actionable data.

### **Gender**

Female survey respondents outnumbered male respondents by 57% to 41%. According to the U.S. Census Bureau statistics from April 1, 2020, females outnumber males in Iowa by a much

---

<sup>2</sup> <https://americanresearchgroup.com/moe.html>

smaller margin of 50.2% to 49.8%.<sup>3</sup> Census data shows the percentage of females in the CISA ranges from a high of 51.4% in Poweshiek County to a low of 47.8% in Story County. While interesting, the female bias to the survey responses is similar to what SmartSource Consulting has seen in other broadband surveys in Iowa. Possible explanations for this imbalance may be interest in the topic or that female heads of household are more likely to make buying decisions on internet service.

## **Age**

The age distribution of the survey respondents was consistent with Census data, except for a shortage of persons under the age of 20. This is to be expected from a survey that is taken primarily by heads of households.

## **Household Income**

Survey respondents tended to report higher household income than Census figures would support. 39.7% of the respondents reported an annual household income of \$100,000 or greater. While exact Census breakdowns on income level are not yet available, this likely represents an over-representation of higher income households.

## **Ethnicity**

Despite outreach efforts to minority populations across the CISA, the percentage of survey respondents who identified as White or Caucasian (93.6%) was greater than overall 2020 Census figures for Iowa (90.6%). Two ethnic groups in particular - Black or African American and Latinx – were significantly underrepresented in the survey sample.

## **Education Level**

The education level of the survey respondents is likely much higher than the general population. 61.1% of the survey respondents reported that they had a bachelors or graduate college degree. Only 9.2% reported having a high school education or less.

## **Access**

Internet providers utilize a variety of means to connect their customers to their backbone network. This final connection is often referred to as the “last mile”. There are two primary types of networks that can provide this last mile connection. **Terrestrial networks** are ones that use some form of wiring to connect the end user to the network. Terrestrial network operators use some combination of copper DSL over telephone networks, copper hybrid fiber-coaxial (HFC) over cable networks or fiber optic connections. Because customers are “hard-wired”, terrestrial-based networks tend to offer higher reliability and the potential for greater speeds, depending on the type of technology used.

**Non-terrestrial networks** utilize some form of radio frequency wireless technology to connect to the customer. Providers using fixed wireless use antennas on a tower or other tall structure

---

<sup>3</sup> <https://www.census.gov/quickfacts/fact/table/IA/POP010220>



to beam data through the air to an antenna attached to the customer premise. Mobile wireless providers use cellular technology to transmit data to and from the customer, who then uses a device such as a mobile hotspot to connect to devices using Wi-Fi. Satellite providers have traditionally utilized satellites in geosynchronous orbit to transmit and receive data from subscribers with small dish antennas at their premise.

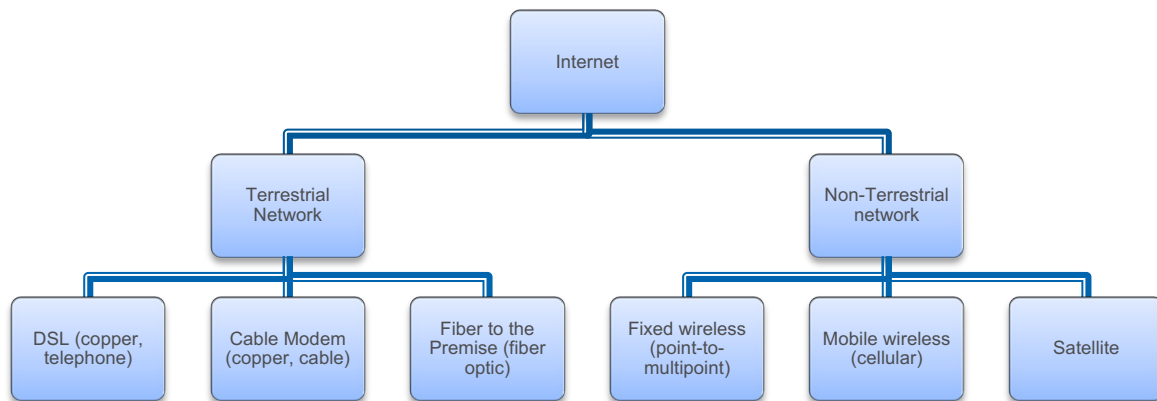

Figure 3 - Last Mile Networks

One of the primary goals of the Central Iowa Broadband Internet Study Survey was to help identify areas of the CISA where access to broadband is not available. On one hand, it could be argued there is access everywhere due to the near universal availability of satellite-based internet service. However, services provided by traditional satellite internet companies such as HughesNet and others are generally considered less desirable than terrestrial connections due to slower speeds, higher latency and susceptibility to weather. Newer satellite services such as Starlink, using low earth orbit satellites, promise better performance when fully deployed.

The survey showed a clear divide between town/city respondents and those living in rural areas regarding what type of network their provider uses. Of internet providers in a town or city, only 1.5% reported they use a non-terrestrial provider. In rural areas, this figure jumps to 27.5%. Of the rural respondents using non-terrestrial networks, 40.9% rely on satellite-based providers, 29.7% connect to a fixed-wireless provider and 29.4% use a cellular network.

The fact that more than a quarter of rural survey respondents have a non-terrestrial provider does not necessarily mean a terrestrial network is not available to them. Among the reasons a consumer might choose satellite, fixed wireless or cellular over a wired alternative include available speeds, reliability, experience with existing providers and other reasons. But it is likely

that a sizeable portion of the non-terrestrial connected customers do so because there is simply no other choice.

## Adoption

For purposes of this report, a survey respondent that has a home internet connection is considered an adopter. Adoption rates were high, with 90.4% of survey takers reporting they subscribe to internet service at home. That figure is slightly higher than the 85-86% estimates reported by the U.S. Census Bureau as of 2018.<sup>4</sup> However, since the Census estimates are from three years ago, it is likely the adoption rate found in the Central Iowa Broadband Internet Study survey is consistent with national trends.

## Adopters

The residential survey asked consumers a series of questions about their internet service and how they use it.

## Pricing

Overall, 73.7% of residential internet customers in the CISA say they are paying \$61 or more per month for internet service. A significant share (17.4%) are paying \$100 a month or more for their service.

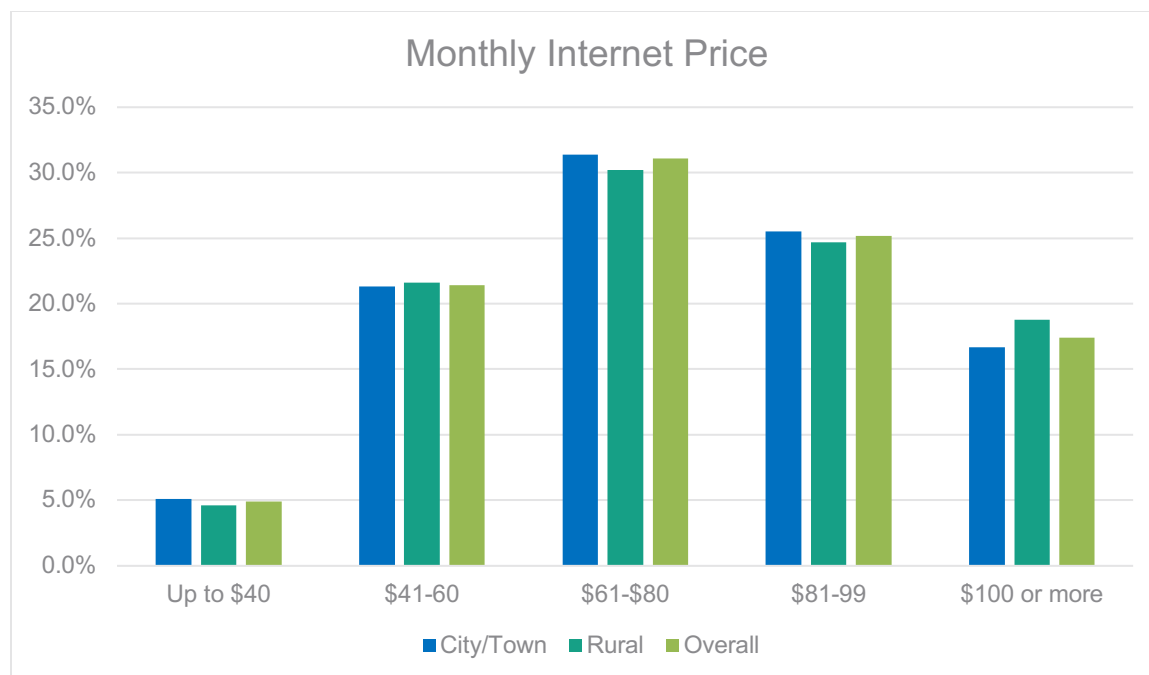

Figure 4 - Monthly Internet Price

<sup>4</sup> <https://www.census.gov/content/dam/Census/library/publications/2021/acs/acs-49.pdf>

## Importance of Broadband

The survey also asked consumers to rate the importance of broadband in relationship to several community attributes. Overall, the results show that residential consumers in the CISA are very aware of how important fast, reliable broadband service is within their individual households and the communities where they live.

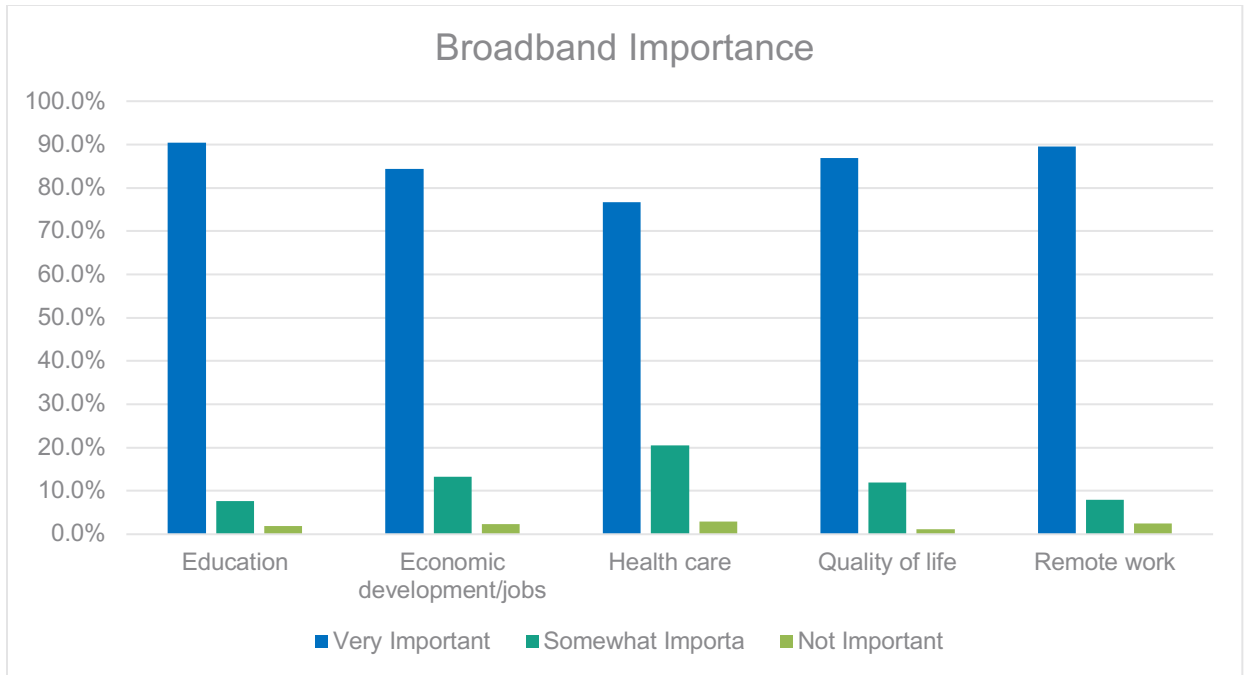

Figure 5 - Broadband Importance

## Internet Applications

Among survey respondents, the most cited uses of home internet were email, shopping, social media, streaming video and banking/investing. Among these common uses, the prevalence of streaming video from services such as Netflix, Disney+ and others is a key driver of the explosion of bandwidth uses at the consumer level over the past several years. It has also placed considerable strains on the ability of internet service providers to keep up with the demand for more speed and more bandwidth.

## Non-Adopters

Non-adopters (meaning, households without an internet subscription) can be divided into two categories: non-adopters by choice (i.e., internet is available, but they do not subscribe) and forced non-adopters (i.e., no internet service is available at their location).

---

*“The only option we have at our address is Satellite internet - it is extremely expensive at over \$200 per month. The service is unreliable - if there is a storm or rain then we lose service. We have looked into DSL, the phone lines at our address are so out of date that they have to be consistently repaired when it rains, also, DSL is not currently an option.”*

*- Comment on Broadband Internet Survey*

---

To say some people choose not to adopt internet at home is somewhat misleading. In the survey, non-adopters were asked the reasons why they don't have a home internet subscription. 52.6% said it was because the price of available internet options is too high. 14.9% said the slow speeds available to them were holding them back, while another 8.2% indicated available options were not

reliable enough. By selecting one of these reasons, the survey taker is indicating that non-adoption is less of a choice than it might appear. For example, if price was no longer an objection, the overall adoption rate in the CISA could rise significantly.

6.7% of survey respondents said that no internet service is available at their home. For many of these respondents, it likely means that there is no terrestrial network available. Cable networks are usually limited to more densely populated areas. Fiber networks have been built in many rural areas, but generally not in rural areas served by larger companies such as CenturyLink/Lumen, Windstream or Frontier. While the copper telephone network is available universally, DSL broadband service may not be available due to the total distance from the nearest fiber interconnection.

Survey respondents who said that internet service is not available at their home were asked how much they would be willing to pay for service if it was available. Overall, 60.9% reported that they would be willing to pay \$61 or more per month for internet service if it were an option. Non-adopters in cities and towns appear to be more price sensitive than those in rural areas. While 62% of rural residents are willing to pay \$61 or more for internet if it were available, only 36% of city/town residents say the same.

In these areas not served by a terrestrial network, only satellite or fixed-wireless service may be available, however, even when available, they may not be an option. Either of these two last mile options usually require a direct line of sight between the transmitting satellite or

tower and the consumer's home or business. The presence of large trees on the customer's property is often a significant obstacle to receiving service. A prospective customer may be faced with removing or trimming trees in order to "see" the satellite or wireless provider antenna or installing reception equipment beyond the tree line at significant cost. Terrain can also be a challenge. A home located in a low area may not have line of sight to a wireless or satellite signal, and changing the terrain is not an option. Rural customers especially have been forced to be creative to receive service, locating antennas on grain bins, poles or other

---

*“We have the highest data plan available in our location, with any available provider. We had to have several large trees taken down to get the service we do have.”*

*- Comment on Broadband Internet Survey*

---

structures on their property. And finally, other structures may stand in the way of a good signal. If those structures are on the occupant's property, workarounds may be available. But if that structure is on a neighbor's property those options may be off the table.

For some consumers, the provider of last resort may be a cellular signal. All the major mobile wireless providers offer a data device or mobile hotspot that can be used to provide connectivity to devices without cellular capabilities, such as computers. Or a customer can tether their cellular phone to a device to use its wireless data. An advantage of cellular, especially 4G, is signals are less affected by terrain and trees. However, data offerings by cellular wireless services tend to have significant limitations consumers must consider. First, download and upload speeds are likely to be much lower than what could be provided by terrestrial networks. Like any wireless signal, cellular can be subject to interference. Besides speed, the most significant limitation is total data allowance. While many cellular companies advertise unlimited data, the fine print usually specifies that customers may be subject to overage charges or data slowdowns once reaching a certain consumption allowance.

### Consumer Attitudes

Just because a home or business has broadband internet service does not mean they are happy with that service. The survey attempted to gauge consumer attitudes about their internet service. A great deal of data and anecdotal evidence indicates that there is an undercurrent of dissatisfaction among internet consumers in the CISA.

### Overall Satisfaction

A common tool used to measure consumer attitudes about companies is called the Net Promoter Score, or NPS. The NPS asks a simple question: "On a scale of 0 to 10, how likely is it that you recommend (company or service) to a friend or colleague?" The graphic below is a visual representation of how those answers indicate if a consumer is a PROMOTER of that product/service, a PASSIVE, or a DETRACTOR.

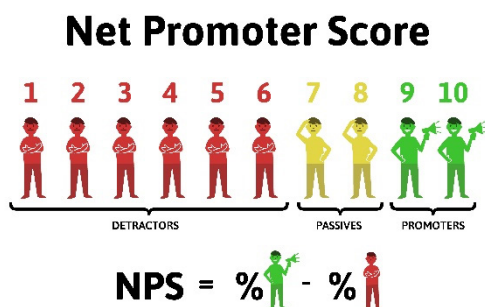

Respondents are grouped as follows:

- Promoters (score 9-10) are loyal enthusiasts who will keep buying and refer others, fueling growth.
- Passives (score 7-8) are satisfied but unenthusiastic customers who are vulnerable to competitive offerings.
- Detractors (score 0-6) are unhappy customers who can damage a brand and impede growth through negative word-of-mouth.

Net Promoter Scores are different across different industries. Internet service providers are consistently ranked among the lowest in terms of NPS. NICE Satmetrix, the co-developer of the Net Promoter Score, reported average NPS for internet service providers in 2018 was -1.0.<sup>5</sup>

For purposes of the Central Iowa Broadband Internet Study survey, we asked the following question:

**“How likely is it that you would recommend your Internet Service Provider (ISP) to a friend or colleague?”**

Dozens of providers serve the CISA. Overall, among all respondents to the question on the residential survey (4,204), the Net Promoter Score was -43.9. Respondents in cities or towns were slightly more favorable toward their provider (-40.0) compared to rural respondents (-50.7) and those whose residential location is unknown (-62.5).

---

*“In today’s farm setting it is almost impossible to use the internet to keep up with the demands of today’s farm equipment from a data transmission standpoint.”*

*- Comment on Broadband Internet Survey*

---

Net Promoter Scores varied widely among the different providers in the CISA. In general, smaller independent providers (i.e., cooperatives, mutuals and municipals) had NPS’s of greater than zero, with the highest-ranked providers capturing scores of +60 to +85. Larger providers tended to have NPS’s below zero, with scores as low as -56.0.

In addition to the use of the Net Promoter Score metric, the survey also asked residential consumers to rate their provider on several satisfaction metrics. The survey used a standard Likert Scale<sup>6</sup>, then assigned a score to those responses as follows:

- 5 – Very Satisfied
- 4 – Somewhat Satisfied
- 3 – It’s OK
- 2 – Somewhat Dissatisfied
- 1 – Very Dissatisfied

Respondents were asked to rate their overall satisfaction with their internet service, as well as their rating for several key characteristics of internet service: reliability (frequency and length of service interruptions), customer service experience, price, speed and data allowances. Using this scale, a score of three would be considered average.

---

<sup>5</sup> <http://info.nice.com/rs/338-EJP-431/images/NICE-Satmetrix-infographic-2018-b2c-nps-benchmarks-050418.pdf>

<sup>6</sup> <https://www.surveygizmo.com/resources/blog/likert-scale-what-is-it-how-to-analyze-it-and-when-to-use-it/>



Figure 6 - Average Rating by Service Characteristic

While the graph above represents average ratings among all providers, these metrics varied among individual providers similarly to the variance of Net Promoter Scores. It is not surprising providers with higher NPS's had higher ratings on these metrics.

### Speed Tests

A key element of the survey was speed testing. During the survey, respondents were asked to conduct a speed test using the popular Ookla platform [www.speedtest.net](http://www.speedtest.net), then transcribe the results into the appropriate fields on the survey form. When the survey was closed, results were reviewed and instances where respondents transcribed their speed test with input errors were removed for accuracy purposes. As a result, a total of 4,194 download tests and 3,074 upload tests were recorded and used for analysis.

The average download speed recorded was 80.7 Mbps, but the median download speed was just 34.0 Mbps. This indicates that a smaller number of higher speed tests were offset by a larger number of lower tests.

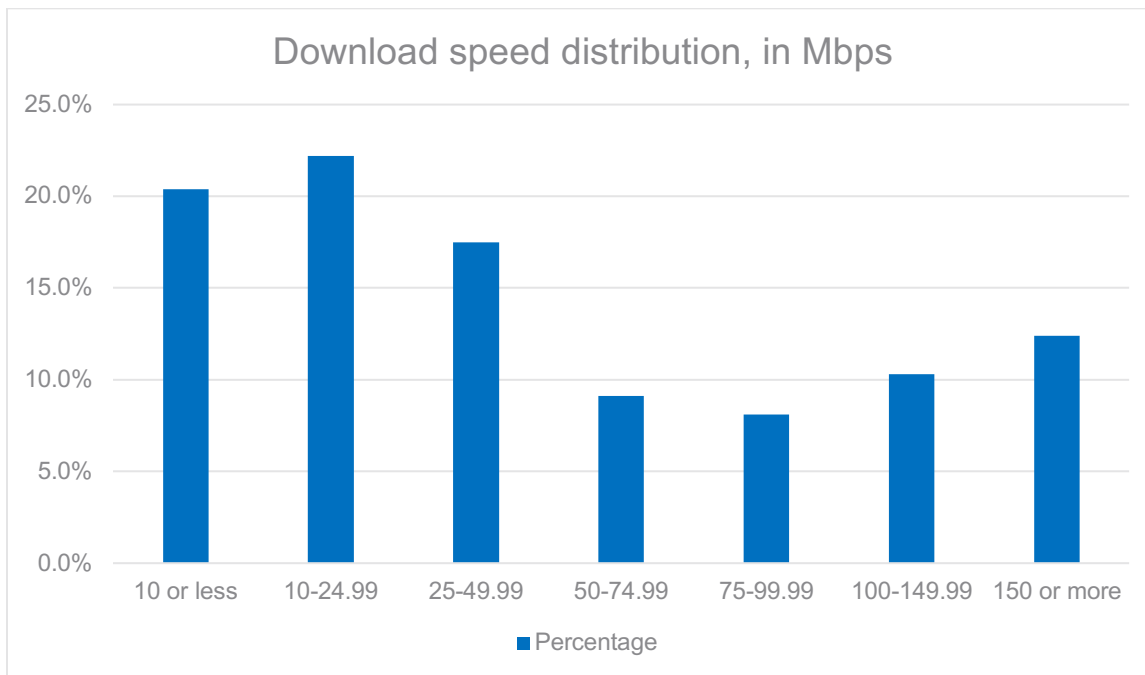

Figure 7 - Download Speed Distribution, in Mbps

The median download speed for city/town respondents (101.6 Mbps) was three times higher than the median speed among rural respondents (34.0 Mbps). A similar disparity exists in the percentage of respondents whose download speeds did not meet the FCC’s definition of “broadband”, 25 Mbps. Area wide, 42% of download speed tests failed to reach 25 Mbps. The number of town/city respondents failing to meet the threshold (32.1%) was double the number in rural areas (64.3%).

---

*“We need better speeds in rural areas, just as cities have.”*

*- Comment on Broadband Internet Survey*

---

Similar gaps were found when examining upload speeds. The FCC defines the upload threshold for broadband to be 3 Mbps. Across the entire CISA, 31.5% of upload speed tests failed to meet the FCC

definition. Again, a higher percentage of rural speed tests (38.9%) were below the threshold than town/city tests (15.6%).

Several factors can impact the speed test results that a respondent received. Many of those factors are beyond the control of the internet service provider. For example, while the survey instructions encouraged respondents to take the speed test from a device that was hard-wired into a gateway or router using an ethernet cable, it is likely that most of the tests were taken over a Wi-Fi connection. While Wi-Fi technology has advanced greatly over the years, many customers are likely to still have older routers with poorer performance. Also, a variety of factors impact Wi-Fi signals within a home and can significantly reduce performance. The speed that a provider advertises to a customer may in reality be delivered to the router itself but is not delivered to the device.



Despite this, the speed test results offer valuable information because they speak directly to the customer’s experience. If the customer’s reality is slow speeds in their home due to Wi-Fi limitations, the provider’s reality may not matter to them. They will perceive that their internet is under-performing and that will impact their overall opinion of their provider. Ideally, providers in the CISA will request the raw data from their own customers so they can conduct their own analysis and identify ways to close the gap between network reality and consumer perception.

**Survey Summary**

Survey results were primarily analyzed by SmartSource Consulting. 4,838 persons participated in the survey from across the 11-county region. Of note, surveys lacking the minimum needed input information were removed. Because of that, the number being analyzed for results is lower than what may have been shown on the survey dashboard initially.

**Adoption and Usage**

- 90.0% of survey takers reported they subscribe to internet service at home
- 6.8% reported no internet service is available at their home
- 3.2% reported internet service is available at their location, but they do not subscribe
- Among non-adopters, the cost of internet service was the most cited reason. Other common reasons for not having internet included poor reliability among available providers, speeds that are too low or not having a device with which to use the internet.

For more information on adoption and adoptions strategies, see Appendix F which describes the results and recommendations from the national governors’ recent study.

**Speed Tests**

A total of 4,195 download speeds were recorded. A lesser number of upload speeds (3,075) were recorded.

For comparison's sake, analyzing the median value is more useful than analyzing the average as, in this case, the average is significantly skewed due to a relatively small number of speed tests on the higher end of the range.

**Median and Average Speeds**

	Download (in Mbps)		Upload (in Mbps)	
	Median	Average	Median	Average
All Tests	34.0	80.7	10.8	50.3
Town/City Tests	49.3	101.6	16.1	63.4
Rural Tests	15.7	37.8	2.5	23.7

## Advertised Speeds Compared to Recorded Speeds

Advertised “Up To” Download Speed	Download		Upload	
	Median	Average	Median	Average
Less than 10 Mbps	5.1	13.2	0.9	8.9
10-24 Mbps	13.0	15.6	1.4	15.6
25-49 Mbps	30.0	37.0	4.5	20.0
50-99 Mbps	53.1	66.5	15.0	27.0
100-249 Mbps	94.0	106.5	18.0	58.6
250-499 Mbps	240.0	224.6	39.0	96.5
500-999 Mbps	132.6	213.6	62.2	145.4
1,000 Mbps	201.5	319.8	61.3	222.1

### Summary Observations

- The median download speed for town/city survey respondents was approximately 3x higher than rural speeds
- Overall, 42.6% of download speeds tested were lower than the FCC broadband definition of 25 Mbps
  - Among rural speed tests, 64% were lower than 25 Mbps
  - Among town/city speed tests, 32.2% were lower than 25 Mbps
- Overall, 31.5% of upload speeds tested were lower than the FCC broadband definition of 3 Mbps
  - Among rural speed tests, 64.0% were lower than 3 Mbps
  - Among town/city speed tests, 32.1% were lower than 3 Mbps
- In most cases, the speed test recorded was on the lower end of the range of advertised speeds. This does not necessarily mean that, in all cases, providers are advertising speeds that are not achievable. Other factors that would affect speed test results must be considered, including the tester’s device and how it was connected to the home internet connection (e.g., wired vs. Wi-Fi).

### County Survey Results Maps

The below maps show survey results for Adair County. The first map displays the actual speed tests that were recorded for survey participants in the County and the second shows the respondents’ overall satisfaction with their internet service. The maps for the other counties can be found in Appendix C.

The pink areas of the background represent Targeted Service Areas by the State of Iowa. These are areas the State has determined are underserved for broadband, and thus, are eligible for grants. The white background indicates adequate broadband is available. In both the speed

test and satisfaction maps, there are survey results that indicate a need for better broadband in areas that are shown as not eligible. These areas could be appealed to the State in the grant process to see if they could be changed to be eligible for grants.

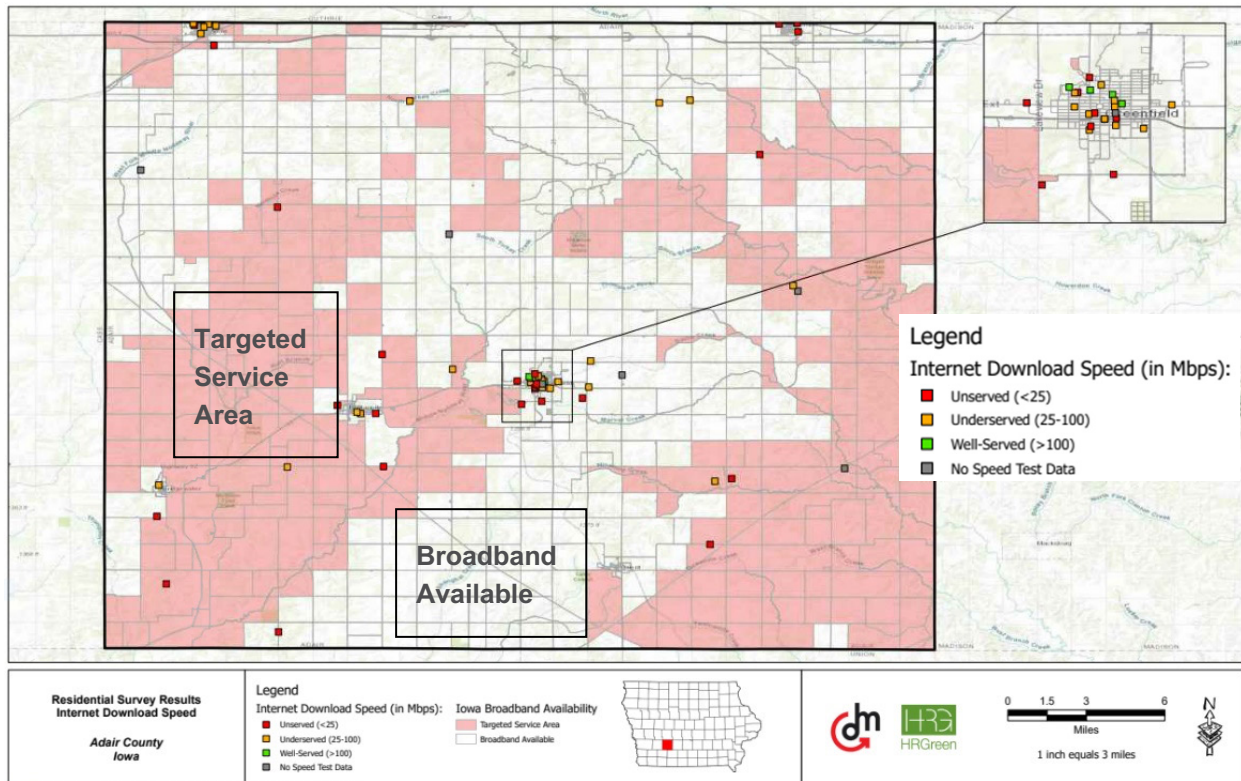

Figure 9 - Speed Test Results in Adair County

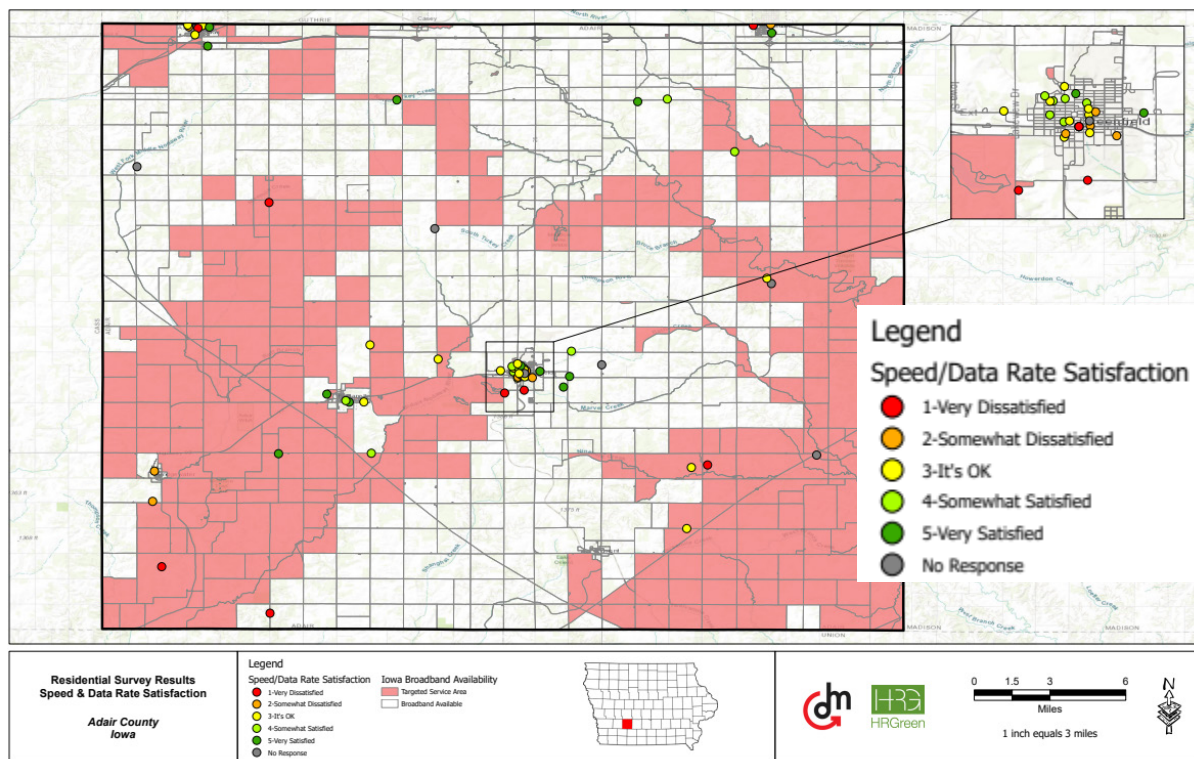

Figure 8 - Internet Satisfaction in Adair County

## Broadband Technology

Across the United States, Internet Service Providers (ISPs) are deploying a variety of technologies to deliver broadband services. Each of these technologies bring with them certain advantages as well as disadvantages, including cost of deployment, coverage extent and other financial and technical issues.

In Central Iowa, nearly every home has access to DSL service, which provides broadband speeds of up to 25 Mbps download and up to 3 Mbps upload (25/3 Mbps) service. This service meets the minimum requirements from the FCC to qualify as high-speed broadband, but survey speeds reported as part of this study indicate many homes are receiving speeds significantly below this “up to” qualifying speed.

From a broader perspective, the State of Iowa, in its recently approved broadband grant funding legislation, has acknowledged the 25/3 speed designation is no longer sufficient to meet the state’s residents. In the new grant program, any area which is not receiving at least 80 Mbps is considered a Targeted Improvement Area. The program further clarifies Targeted Service Areas by tiers:

- Tier 1: Maximum download speed of less than 25 Mbps and a maximum upload speed of less than 3 Mbps
- Tier 2: Minimum download speed of greater than or equal to 25 Mbps but less than 50 Mbps
- Tier 3: Minimum download speed of greater than or equal to 50 Mbps but less than 80 Mbps.

Under the state program, grant funding (further defined elsewhere in this report) is available for markets in each of these tiers, with a goal of improving service to 100/100 Mbps symmetrical across Iowa. There is an exception in the funding model for areas not currently in Tier 1, allowing 100/20 Mbps in areas which are hard to serve to due terrain and geography. In nearly all cases, the exception for 100/20M bps matches areas further defined below as remote.

While it is not the role of The Partnership to judge the adequacy of technologies or coverage, it is important to fully understand the important impacts of this change to funding efforts to bring better broadband to the region. Equally important, while fiber-optic connectivity is viewed as the gold standard due to its high capacity and symmetrical service, Central Iowa’s highly diverse population density, terrain, and other features would make it cost prohibitive to envision and build a full Fiber-To-The-Home solution.

Because of this, HR Green and its study partners instead recommend a path in which technology is matched to the varying demographics of the region to create the most cost-efficient and highest impact solution for each individual area.

## **Defining Broadband Service Areas**

Varying service area types face different challenges. In some parts of the Central Iowa Study Area (CISA), **access** to high-speed internet technology is the key concern. Conversely, in some inner-city and urban areas, physical technology may be deployed but cost makes adoption prohibitively expensive for lower-income residents. While there is no universal definition, we find it useful to consider a categorization of service areas as follows:

### **Urban**

In larger, metro settings, population densities support the deployment of higher capacity technologies. Copper-based technologies have been largely supplanted by the deployment of coaxial cable or fiber optic services. In many urban areas of Central Iowa, there are at least two providers who provide at least 100/20 Mbps service resulting in some level of consumer choice between providers.

For the purposes of grant opportunities, the FCC defines urban areas as cities with a population of 50,000 or more, with the city boundaries being the same as its jurisdictional boundaries.<sup>7</sup> Urban areas typically benefit from the best availability of internet service providers and broadband market competition. Population density incentivizes industry investment due to economies of scale and scope in attracting the greatest number of customers relative to the geographical area of deployment.

However, while access to acceptable broadband is generally present in these areas, there are remaining challenges. The most apparent from this survey is that while the technology is present, adoption is often precluded due to affordability issues. Put more simply, the cost of service exceeds the capacity of residents in socioeconomically disadvantaged areas.

A second challenge in urban areas, which was beyond the scope of this study, is digital redlining may occur. Individual provider coverages were not analyzed in this market to a sufficient depth to determine whether this is present in Central Iowa, but there are documented cases where providers have not deployed next generation technology to socioeconomically disadvantaged neighborhoods, instead deploying capital in suburban or other geographies which result in higher take rates and revenues.

### **Suburban (Including Towns)**

Throughout this study, many suburban geographies were generally well-served with broadband above the 100/20 Mbps standard. Suburban areas generally feature relatively dense population, more modern infrastructure and income levels which make costs less of a barrier to adoption. Since many suburban areas have a widespread grid of sidewalks, roads and rights of

---

<sup>7</sup> <https://docs.fcc.gov/public/attachments/DOC-358434A1.pdf>

way, placing underground or above ground equipment can be easier in avoiding obstacles or existing utilities. The presence of higher-value business and enterprise customers in these markets also makes deployment of fiber optic service a positive investment for providers in these markets.

It is important to note most homes and businesses in suburban markets have access to at least two (and sometimes more) providers capable of meeting the 100 Mbps download speed. Recently, companies such as MetroNet have begun installing new FTTH in communities in Central Iowa that have other providers (referred to as “overbuilding”).

### **Rural (Unincorporated Areas)**

Much of the current national policy debate, and significant funding both approved and currently under consideration is focused on solving the rural broadband issue. The Digital Divide, as this issue is known, is not limited to just rural America, but this has received the headlines in the current national policy debate. The results of this study validated that this divide is real and results of speed tests can be found elsewhere in this study.

The FCC has formally reinforced its definition of “rural” for the purposes of receiving rural telecommunications development grants and eligibility for rural health care programs as counties with a population density of 100 persons per square mile or less.<sup>8</sup> They maintain that the definition based on the Census Bureau’s Core Based Statistical Areas is the most reliable measure of rural areas. Due to their low population density, topographical challenges, widespread geographical distances, investment in broadband is often cost-prohibitive in the balance between cost of investment and potential customer subscription revenue.

### **Remote**

It is not a coincidence that the findings of speed tests in this report showed the largest disparity in speeds for homes, farms and businesses located in the most remote portions of Central Iowa. The low population densities of remote locations make the economics of serving these potential customers less attractive for commercial service providers, resulting in less investment in technology upgrades and a higher reliance on slower technologies such as DSL over copper infrastructure.

A review of the Iowa Broadband Availability Map shows that most of the rural areas in Central Iowa are, in fact, designated as Targeted Service Areas and eligible for funding to both public and private sector providers who want to deploy next-generation networks to meet the state’s new 100/20 Mbps standard, as shown in Figure 10 below.<sup>9</sup>

---

<sup>8</sup> FCC document 04-166. Docket WT 02-381. REPORT AND ORDER AND FURTHER NOTICE OF PROPOSED RULE MAKING. Facilitating the Provision of Spectrum-Based Services to Rural Areas and Promoting Opportunities for Rural Telephone Companies To Provide Spectrum-Based Services

<sup>9</sup> FCC 2020 Broadband Deployment Report: <https://docs.fcc.gov/public/attachments/FCC-20-50A1.pdf>

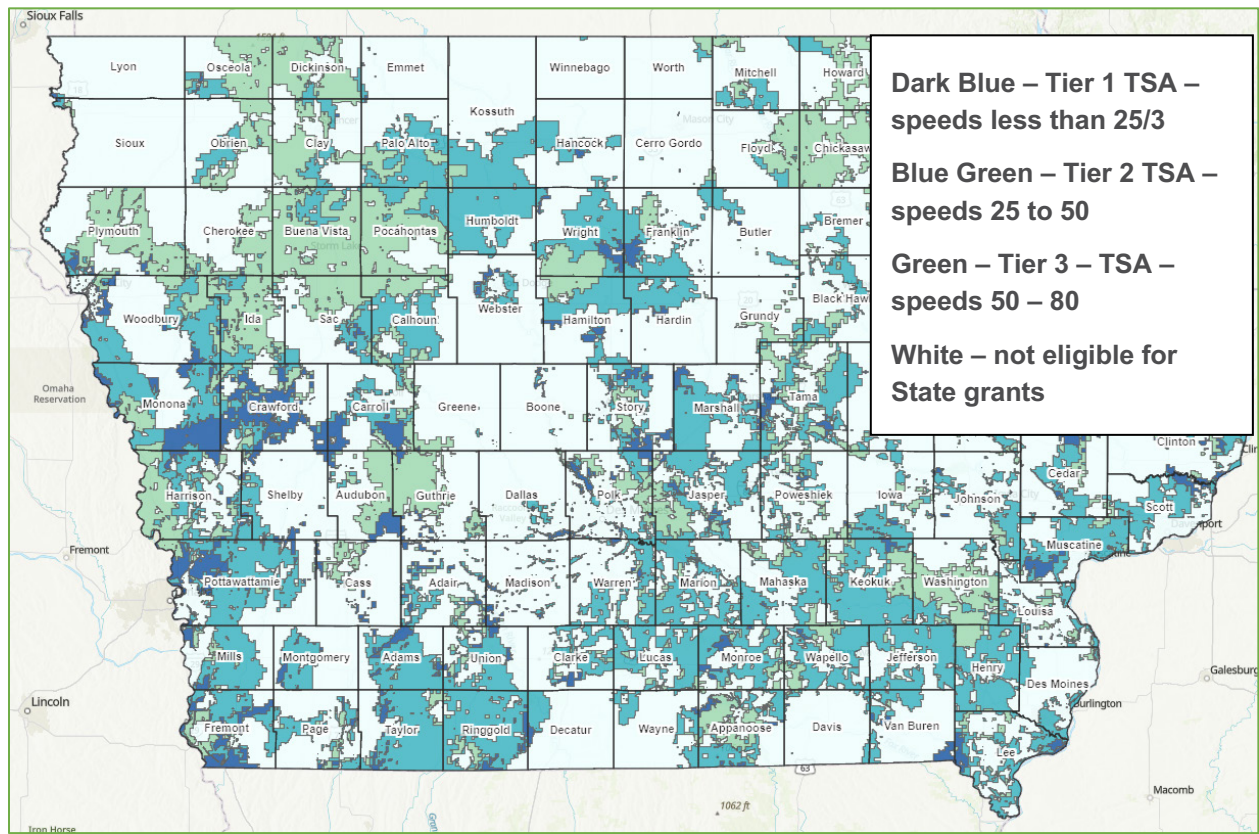

Figure 10: Iowa Broadband Availability Map Targeted Service Areas

**Evaluating Current and Emerging Broadband Technologies**

Based on the current evolution of broadband funding at the state and national level and the economic realities of broadband deployment costs, it is crucial to understand the relative advantages and costs of various broadband technologies. The information below is intended to provide a basic understanding of the most common current technologies, along with a discussion of emerging technologies such as Low Earth Orbit (LEO) satellite service.

Broadband network performance is frequently judged by throughput (or speeds). However, a more holistic evaluation of technologies will also consider more technical components, which make them more or less supportive of emerging use cases like two-way video (videoconferencing), distance learning, telemedicine and other uses.

For purposes of this review, technologies were evaluated on the following criteria:

- **Area of Coverage:** Fixed wireless and satellite broadband have the advantage of covering large geographic territories from a single point of presence such as a tower or orbiting station. Copper, coaxial and fiber require direct connection and physical network at each individual service point.

- Cost to Subscribers: For lower-income homes and small businesses, broadband service plans can represent a meaningful barrier to adoption. Cost of service, therefore, is a key consideration in evaluating possible technical solutions.
- Deployment Cost: Deployment of broadband technology nearly always involves the deployment of large amounts of capital with a business plan that typically seeks to cover the cost of that deployment plus interest, operating expenses and profit over a long-service window (typically 4-20+ years). Costs vary significantly from high-capital deployments for fiber and coaxial cable to lower cost technologies such as fixed wireless or satellite.
- Throughput/Speed/Data Rate: The amount of data per unit of time successfully delivered through the network over a communication channel between two points.
- Service Reliability: The frequency of potential outages that compromise consistent access to the service. Wireless service is inherently less reliable due to propagation characteristics being heavily influenced by obstacles, clutter, and weather.
- Latency: The delay in the amount of time it takes for a unit of data to reach its destination across a network.
- Jitter: The variation in latency when transferring data. It is a defining metric in the network's ability to consistently transfer real-time data traffic such as Voice over Internet Protocol (VoIP), video conferencing and virtual desktop infrastructure.
- Packet Loss: the measure of unsuccessful attempts to transfer units of data to its destination.

### **Fiber to the Premises (FTTP)**

Fiber optic deployments rely on the construction of networks that convert electrical signals carrying data to light and send that information directly over small glass fibers about the diameter of a human hair. The key advantage of fiber optic cables is its capacity to carry massive amounts of information at nearly the speed of light, resulting in service that is symmetrical, low latency and capable of extremely high speeds. FTTP deployments are frequently viewed as the “gold standard” due to the technical advantages noted above. Providers of FTTP deployments frequently offer service plans of 100/100 Mbps or 1,000/1,000 Mbps (or Gigabit service).

Fiber deployments are either completed with buried or aerial construction methods. Buried fiber is the most secure method and avoids many of the risks of aerial deployment because they are immune to the effects of wind and ice damage. On the other hand, many providers prefer to deploy aerial cables on public rights of way and existing utility pole infrastructure. Aerial deployments create more risk of service disruption but the initial capital deployment for aerial fiber can be as much as 40 to 50% less than the cost of a buried deployment.

Fiber optic service does have many technical advantages, but the cost of deploying the physical infrastructure and supporting electronics necessary to operate the network can make fiber optic too expensive for many Rural and Remote areas. This can be especially true in areas where geology includes rock and other difficult-to-dig areas.



### **Coaxial Cable (DOCSIS 3.0/3.1)**

Most of the homes and businesses served by the incumbent cable providers are receiving their video and broadband on a technology known as Data Over Cable Service Interface Specification, DOCSIS 3.1. DOCSIS was launched by the cable industry to convert its original video distribution plant to a system capable of carrying not only video, but two-way transmission of data to and from customer premises. DOCSIS relies on a hybrid of coaxial cable and fiber optic cable to deliver services.

Like fiber optic networks, DOCSIS service technology relies on either buried or aerial distribution of cables to carry data and video to customer premises. The implementation of DOCSIS 3.1 allowed the cable industry to compete with new fiber-to-the-home providers by significantly increasing download speeds for customer. The technology is capable of up to 10 Gbps (10 Gigabit) speeds, but most cable service plans currently available in the market feature 100 Mbps or 250 Mbps offerings.

One of the limitations of coaxial cable plant is the significant expansion of available upload speeds. Many cable providers, in fact, still offer uploads speeds between 3 Mbps and 35 Mbps. This capacity has been sufficient for many of the historic uses of broadband, but many emergent uses (telemedicine, video conferencing, remote learning) rely on both up and download capacity and there have been reports of dissatisfaction with DOCSIS in this more symmetrical environment.

The cable industry is also investing in direct Fiber to the Premise for business and enterprise customers, while continuing to develop future DOCSIS evolutions to increase both download and upload speeds.

### **Digital Subscriber Link (DSL)**

DSL service was implemented by the incumbent telephone companies as a replacement for dial up internet. The technology has seen several upgrades and is capable of supporting asymmetrical speeds of up to 25/3 Mbps. DSL is one of the most prevalent technology deployments available in the Central Iowa Broadband Internet Study service area, as local and incumbent providers have continued to update older 10/1 Mbps DSL service to newer technologies capable of meeting the federal broadband standard of 25/3 Mbps and, with some upgraded equipment speeds of up to 100/10 Mbps.

One concern with DSL is the use of “up to” speeds when compared to actual speeds realized by customers. Because DSL is reliant on existing copper pair telephone lines, physical proximity to transmitting equipment is a key factor in determining actual speeds. While customers who are close to DSL gear receive speeds near the advertised speeds, there is a significant degradation of DSL speeds as customers move further away from the point of presence.

DSL, on the other hand, continues to provide some of the lowest cost of service in the industry. The typical DSL internet bill is in the \$50 to \$60 per month range, which compares favorably with the pricing of GEO satellite providers.

## **Fixed Wireless**

A large section of the Central Iowa Broadband Internet Study Area relies on fixed wireless as a primary broadband technology. Fixed wireless internet uses radio waves transmitted from a cell tower to foster an internet connection. This connection can be transmitted over either federally licensed spectrum or via unlicensed spectrum. Unlike the wired services outlined above, fixed wireless simply relies on an exterior antenna to provide homes and businesses with broadband level services.

Fixed wireless also is different from satellite broadband in that signals are usually connected at the tower to a backhaul fiber network to carry the signal onward to the internet. While speeds and latency are generally inferior to fiber and coaxial technologies, speeds and latency are generally superior to satellite service.

Fixed wireless internet broadband is frequently a positive alternative to traditional DSL service, offering higher connectivity speeds than those available from DSL providers. Because it is not dependent on physical connections, it is well suited to rural and remote settings. Many wireless providers offer low latency and higher data allowances that are available from satellite providers that are a traditional alternative to DSL in rural and remote geographies.

Fixed wireless technology does have some distinct technical challenges. First, fixed wireless relies on a direct line of site from the antenna to the tower site transmitting the signal. While fixed wireless is capable of serving many addresses and a large geography from a single tower, trees, hills and other topography can make connections less efficient and service coverage impossible. Second, the technology is subject to disruption from weather and frequency disruptions, which can cause service and equipment issues.

## **Satellite Broadband – Geostationary Earth Orbit**

Geostationary Earth Orbit (GEO) satellites have been used as an internet service technology by providers such as ViaSat and Hughes Network Systems. HughesNet was formed in 1996 to provide satellite internet service, and controls roughly 60% of the satellite internet market in the United States.

GEO satellite service represents an improvement over early dial up and copper-based technologies, which only offered speeds up to 10/1 Mbps. Because of this, adoption of GEO satellite service has been primarily in geographies described above as remote, and in some rural and remote areas it represents the only available alternative that meets the 25/3 Mbps FCC standard for broadband.

A report by the Congressional Research Service in August 2021 notes several key challenges with GEO satellites as a technology that supports future-forward broadband needs.<sup>10</sup> The distance data must travel to a satellite in orbit and back results in a lower data rate, higher latency and a lack of reliability in using many real-time applications such as video conferencing. Latency of GEO providers averages nearly 636 milliseconds for the two large commercial

---

<sup>10</sup> <https://crsreports.congress.gov/product/pdf/R/R46896>

providers. Technology experts have noted many challenges with the use of this technology during the recent pandemic.

The report also notes GEO service carries a higher average price to consumers and businesses. The average price of a GEO satellite plan is \$123 per month, compared to an average of \$52 to \$59 per month for traditional wired services.

### **Satellite Broadband – Low Earth Orbit**

While GEO satellite broadband has been available, there are a number of recent announcements from companies who have announced (or are already deploying) constellations of low-earth orbit (LEO) satellites to improve on the traditional challenges with high earth orbit provider services. LEO satellite has promised to significantly improve on speed of service issues, with a particular focus on upload speed improvements.

While industry pundits have been less convinced by the promise of these technologies, on December 7, 2020, the FCC announced SpaceX (Elon Musk’s innovation company) was awarded \$885.5 million in Federal funding to assist with deployment of the technology. This represented one of the largest awards in the Rural Digital Opportunity Fund (RDOF) funding cycle. SpaceX committed to provide high-speed internet service to nearly 643,000 homes and businesses in 35 states.<sup>11</sup>

SpaceX developed the concept of a satellite network to improve broadband in areas with challenges to improving connectivity, which makes it a particularly interesting technology solution for remote geographies in Central Iowa. According to Techradar, Starlink plans to launch over 12,000 LEO satellites to offer internet service anywhere on the planet. The satellites’ much closer distance to earth will greatly diminish the latency issues associated with the much-greater distances of GEO satellites from the earth. The service is likely to be much more affordable, with an initial investment a receiver ranging in cost from \$200 to 500 and less than \$100 in monthly subscription rates.<sup>12</sup>

None of SpaceX’s funding was in Iowa, but it is likely SpaceX will provide services in Iowa without RDOF funds. SpaceX is currently offering its “Better Than Nothing” Beta service, which is delivering between 50 Mbps to 100 Mbps service at a cost of \$99 per month.

Starlink is highlighted here as it is the most market-ready commercial LEO product on the market. Amazon’s Project Kuiper was approved by the FCC to launch and operate more than 3,200 satellites in order to provide broadband service. OneWeb will provide service estimated at up to 200 Mbps and Telesat is projecting service at 50 Mbps. In all instances, latency of the new LEO providers is in the 30 to 60 millisecond range, in tolerance with fixed wireless and some wired connection solutions.

---

<sup>11</sup> <https://spacenews.com/spacex-wins-big-share-of-9-2b-rdof-broadband-subsidy/>

<sup>12</sup> <https://www.techradar.com/news/everything-you-need-to-know-about-spacexs-starlink-plans-for-space-internet>

## Cellular Broadband

The evolution of cellular connectivity through 4G, LTE and now 5G service have created opportunities for some customers to eliminate traditional wired or wireless broadband services and to rely entirely on their cell phone or cellular hotspots as a means to provide home connectivity. Cellular broadband is designed for mobility, particularly in higher traffic areas. It varies widely in service quality depending on service area, signal strength, technology hardware, software protocols, modulation coding and schema, number of active users, applications, and many other factors which can significantly compromise its consistent use and reliability. It can be an option in rural and remote areas where alternatives are not available, but wireline internet service access is likely to be more reliable.

### Technology Options Criteria Evaluation

The following table demonstrates each of the described technologies within given evaluation criteria on a scale of Good = **Green**, Average = **Yellow**, and Poor = **Red**.

	Fiber	Cable	DSL	Fixed Wireless	GEO Satellite	LEO Satellite	Cellular
Area of Coverage	Yellow	Yellow	Green	Yellow	Green	Green	Yellow
Cost to Subscribers	Green	Green	Green	Green	Red	Yellow	Green
Deployment Cost	Red	Red	Green	Yellow	Green	Red	Yellow
Throughput/Speed/Data Rate	Green	Green	Red	Yellow	Red	Yellow	Yellow
Service Reliability	Green	Green	Yellow	Red	Red	Red	Red
Latency	Green	Yellow	Yellow	Yellow	Red	Yellow	Red
Jitter	Green	Green	Green	Yellow	Red	Red	Yellow
Packet Loss	Green	Green	Yellow	Yellow	Red	Red	Yellow

### Matching Technologies to Geography

In an ideal world, there would be available and robust resources to provide fiber optic connectivity to every home and business in the Central Iowa Broadband Internet Study service area. An analysis completed by HR Green estimated the cost of connecting every home and business in the 11-county area, completed as a new, standalone fiber network, approaches \$5.5 billion. To connect all of the parcels in the Tier 1, Tier 2 and Tier 3 options (those highlighted as being underserved or unserved), would be approximately \$770 million (this number derives from the Provider Engagement section on page 62).

There are numerous benefits available to the region to improve service across the geography. Those results are identified elsewhere in this report but total more than \$1.25 billion in economic and other benefits. However, the region's investment can and should reflect an

economically based matching of technologies to the requirements of urban, suburban, rural and remote geographies in the market.

The table below shows the four geographies, and an assessment of which technologies are most likely to improve broadband connectivity collectively. Again, these improvements may not create an entirely level playing field but are intended to reflect an overall improvement in broadband availability to as many residents, farms and businesses as possible, while reflecting the likely availability of funding from state and federal sources and the private sector.

The best available technologies fit is reflected in the following table. **Green** represents a good technology fit. **Yellow** represents a possible technology fit and **Red** reflects a technology fit that is unlikely to be deployed or deliver acceptable service

	Urban	Suburban	Rural	Remote
Fiber Optic	Green	Green	Green	Red
Coaxial	Green	Green	Yellow	Red
DSL*	Red	Red	Red	Red
Fixed Wireless	Red	Yellow	Green	Green
GEO Satellite	Red	Red	Yellow	Green
LEO Satellite	Red	Red	Yellow	Green
Cellular Broadband	Yellow	Yellow	Green	Green

*\* DSL technology is generally viewed by industry experts as incapable of supporting 100 Mbps download across geographies. Additionally, better technology can be obtained for the same cost.*

As part of this study, the consultants prepared an analysis of the projected cost of deployment by Census block and focused on the analysis of the geographical types above. Areas which could be served in a financially sustainable manner by fiber optics have been identified with fiber optic deployment costs per service address to assist private and public sector providers who may wish to leverage grant funds to expand new networks.

In areas where the analysis did not reflect a financially viable deployment of fiber or coaxial cable, the analysis provides a projected cost of deployment for fixed wireless providers. While this analysis is not intended to imply that fixed wireless is not viable in suburban or urban markets, the resultant data is intended to encourage deployment of technologies that meet the Iowa broadband grant eligibility by providing 100/100 Mbps service where feasible and providing at least 100/20 Mbps service in rural and remote areas.

# Stakeholder Meetings

## Stakeholder Meeting Overview

Focus groups exploring the current state of broadband in central Iowa were conducted as part of an 11-county study on how to improve access to broadband for the residents of the Central Iowa Study Area. This series of focus groups engaged leaders from major sectors driving Iowa's economy including agriculture, business, education, and health care to generate insights from their direct experiences when considering the challenges and opportunities of conducting their activities via the Internet.

The focus group participants included industry leaders across Central Iowa who are acutely aware of the advantages and shortcomings of the current availability of broadband service. We also ensured the participants selected were knowledgeable about trends on the horizon that will impact their sectors in the coming years and how those trends will impact future requirements for digital infrastructure in the region.

The COVID-19 pandemic triggered a massive spike in internet utilization in nearly every area of life and most industry sectors. The resulting remote work arrangements, distance education, and telehealth were all standout examples of the accelerated evolution towards the delivery of information, products, and services virtually.

Before 2020, businesses have had varying degrees of willingness to allow knowledge workers to work remotely. At the same time, Iowa businesses have struggled to find skilled talent to fill critical positions. Businesses are now reporting considerable success with the portion of their workforce able and willing to work remotely (both full-time and hybrid) and in their ability to find remote workers to fill open positions.

A pillar of Iowa's economy, agriculture similarly struggles to find and retain an adequate workforce as families shift towards urban areas where more family members can find work. Remote work and education are allowing families who wish to live in less densely populated areas to continue to thrive. Digital infrastructure is also crucial for producers to take advantage of the latest innovations in data management and precision agriculture.

The possibilities of telehealth have been unleashed during the pandemic because of governmental emergency orders and changes to insurance guidelines. For many conditions, in particular mental health and social determinants of health, care outcomes are trending even more positive. The improved access for patients from the comfort of their homes is particularly beneficial to patients who must travel far to their providers, have mobility limitations, or face challenges accessing transportation.

While school doors closed abruptly, education continued. This required a major pivot to online learning by educators, administrators, families, and communities. Primary, secondary, and higher education all encountered significant challenges to keep their students adequately connected and engaged for online learning. Such challenges included: broadband availability, bandwidth, having appropriate technology at home, and the skills to use and maintain the technology. Many primary and secondary schools reached a one-to-one device to student ratio

during the pandemic and intend to expand their virtual learning components in 2021-2022 and beyond.

Available connections, bandwidth limitations, and reliability issues are major themes raised by all stakeholder groups. The ability to view stable, streaming video and participate in virtual meetings e.g., on Teams, Zoom, etc. is emerging as a significant distinction between the have and have nots of the digital divide.

Many stakeholders, particularly agriculture participants, also emphasized the importance of expanding cellular networks which currently have inconsistent coverage across the Central Iowa Study Area. Reliable cellular coverage would render immediate benefits during the implementation of a more robust broadband network.

It should not be a surprise how dependent Central Iowa is on the internet. Despite its importance, focus group participants highlighted how fragile and uneven internet access is across the region. Residents, businesses, and institutions are asking for better connections, more bandwidth, and better reliability. In sum, today's broadband infrastructure across central Iowa not only deepens the digital divide but also limits regional prosperity. The participants in this study were unanimous in their calls for investment to accelerate infrastructure development and service improvements.

## Methodology of Stakeholder Meetings

The Central Iowa Broadband Internet Study stakeholder focus groups were conducted as one element of this 11-county study coordinated by The Partnership. The Central Iowa Broadband Internet Study Area (CISA) includes: Adair, Dallas, Guthrie, Jasper, Madison, Marion, Marshall, Polk, Poweshiek, Story and Warren. The study is managed by The Partnership with oversight and involvement from a Steering Committee of approximately 40 persons selected by the counties. The focus groups were facilitated by Dr. Jeff Kappen and David Foster who were members of the consulting team retained to conduct the overall study.

The focus group subject areas were selected from the sectors that historically have a high dependency on the internet and are drivers to the CISA economy including agriculture, businesses (small, medium, and large), K-12 education, higher education, and health care. In the Central Iowa Broadband Internet Study survey, small businesses reported a high rate of being underserved. As a result of this findings, one of the focus groups was dedicated to small businesses.

A list of possible focus group informants was compiled by the Steering Committee and then the research team worked with The Partnership to issue invitations to those selected. These volunteer focus group participants were chosen based on their understanding of the broadband situation in their areas of expertise at a macro level and on their leadership roles in their respective fields. In the end, 36 stakeholder participants were organized into the five focus groups. By virtue of their responsibilities, participants were able to share their insights into what lies ahead for their organizations and sectors.

Focus group sessions lasted approximately 90 minutes and were conducted over Zoom. Participants were assured their comments would not be directly attributable to them without permission to promote an open exchange of ideas. At the onset of each focus group session, participants introduced themselves and the researchers provided an overview of the overall study and how the focus groups would contribute to its results.

The research team provided participants with recent regional broadband demographic data from the US Census Bureau and speed data collected as part of the Central Iowa Broadband Internet Study survey. The components contributing to user satisfaction, perceived value, and the digital divide (bandwidth, reliability, cost, user technology, and user skills) were referenced and discussed.

Researchers posed initial questions based on areas of interest surfaced in the preliminary results from the Broadband and Post-Pandemic Normal Study and the Central Iowa Broadband Internet Study survey. Participant dialog generated additional topics which were used to guide further discussion and questions.

The researchers took careful notes during the focus group sessions and compared them to recordings to ensure accuracy and completeness. After finishing all of the focus group sessions, the research team aggregated the results for thematic analysis and synthesized the insights into this report.



# Stakeholder Findings

## Agriculture, Medium and Large Businesses

### Participants:

- James Bauer – Bauer Farm in Madison County
- Beth Bornholdth – Iowa Farm Bureau
- Dan Dix – NEW Cooperative (40 locations across Iowa with 600 employees, servicing 7,000 farmers / owners)
- Stacie Eshelman – Greenfield Chamber of Commerce and Mainstreet Greenfield
- Kristi Fuller – Lincoln Savings Bank
- John McConehey – Pella Corporation
- Warren Varley – Varley Family Farm & Midwest Partnership Development Corporation

Participants assessed that Iowa, including Central Iowa, enjoys good economic standing when compared to other states and regions. These leaders in agriculture and business emphasized how critical reliable broadband is for conducting nearly all aspects of their operations. They were largely motivated to participate in the focus group because of their dependency on broadband and the obvious (to them) needs for improvements. Of the stakeholder groups in the study, this was possibly the most outspoken group.

Not surprisingly stakeholders cited quality **broadband is essential to their operations** and their dependency is ever-increasing. What is surprising is the extent to which some enterprises are vulnerable to significant disruptions if they would lose connectivity.

*'Our worldwide data is stored locally. We must be carrier and cable redundant.'*

*'Court documents and IRS filings are now all filed electronically. We pay for two connections.'*

*'11 million of the 26 million Iowa soy and corn acres are being dispatched from one office and sent over the cell network.'*

*'Livestock has performance metrics and analytics which are difficult to do without broadband.'*

*'Commodity markets are open nearly 24/7. All contracts are electronically signed now.'*

*'We had a three-week outage and learned there were only 12 people on a (cell) tower. There was no sense of urgency (by the provider) to repair the connection.'*

Many stakeholders emphasized **cellular is also essential** to business operations asserting and there are near-term benefits and efficiencies which can be realized by expanding cellular coverage and reliability. Participants felt cellular often gets overlooked.

*'All of our tractors are linked to the cloud.' We can't run a business without the internet. Cellular has to be part of the solution.'*

*'We operate 200 semis that are monitored and there are a lot of dead spots.'*

*'We had a board member attend Zoom meetings from his tractor on a hilltop using a hotspot and iPad.'*

**Remote work is beneficial** and is here to stay according to businesses. Iowa has been fighting the war for talent and remote work has broadened peoples' options to work where they want to work and live where they want to live. Businesses shared examples of positions they've previously been unable to fill but are now able to fill by allowing employees to work remotely – even if just part of the time.

*'My brother, who works in Chicago, was able to move back (during the pandemic) and work remotely.'*

*'When we opened up a developer position to allow for remote work, we went from 20 to 80 qualified candidates.'*

*'We have (finally) hired an out of state accountant. There is a scarcity of specialists.'*

*'We've allowed remote work for years. We find people like focus time from home and collaboration time at the office.'*

Whereas there is an increasing dependency on a remote workforce, **poor connectivity is limiting the workforce** for rural Iowa employers.

*'We forced people to go online. Many people couldn't log in because family members were tying up bandwidth.'*

*'Can't find a kid to live in (small town) Iowa without bandwidth. The days of not having bandwidth are going away as parents are replaced by kids who only use a computer.'*

*'I had to install a 100-foot tower in my backyard...not everyone has that option.'*

*'We're losing skilled workforce to the metro areas. We're having to let skilled workforce reside in metros and pay mileage.'*

## Small Businesses

### Participants

- Jeff Dickey-Chasins - JobBoard Doctor
- Eva Helps – Helps Homestead
- Jamie Loggins-Evans – Church Employee
- Tanya Michener – Newton Development Corporation
- Jason Palmer – Nobious

Small businesses, including home-based businesses, emerged as an important segment for inclusion when approximately 25% of the business respondents reported being a home-based business and 50% of those (12.5% of the overall business survey population) were based in rural communities.

Small businesses, of course, increasingly rely on the internet to conduct business. This includes performing value-added functions, interacting with clients and associates, order acceptance, accounting and invoicing, banking, hiring, material purchases, and an extensive list of other essential functions. As nearly all software tools and services have transitioned to cloud-based solutions, all small businesses are largely, if not completely, dependent upon their internet connection.

**Bandwidth** was the primary concern voiced by all small business participants. Each participant shared stories of not being able to conduct business efficiently, or not conduct business at all, when the internet was slow or unavailable. The bandwidth limitations could occur at a business location or when working remotely, but regardless, business was impeded.

*'Our current (broadband) service drops when people are watching HDTV.'*

*'My clients now want to see my face; this is a change.'*

*'We (spouse & I) could not have two meetings at the same time... we had to coordinate our meeting schedules. It got worse when our son came home.'*

**Remote work** over the internet has become increasingly essential for many businesses especially in smaller towns and rural settings. Remote work allows employers to retain the talent they need for their business to prosper. Based on recent experiences, more employees than ever desire to work from home part time or full time.

*'We asked our staff if they wanted an office; some said they'd come in occasionally.'*

Given the internet is essential for the operation of a business, the stakeholders unanimously agreed the **internet should be treated as a utility**. Reliability was a major concern voiced when referencing the current levels of private service.

*'To get a job, to go to school, you have to have broadband.'*

*'Lots of focus on speed and capacity... I'd give back ½ the speed over 25 Mbps for twice the reliability.'*

*'I feel more comfortable hiring abroad than in the US... I don't have to worry about their internet being down... even their cell is great.'*

*'Many of our clients are international and they are shocked we don't have municipal or state sponsored internet.'*

## Telemedicine

### Participants

- Stephanie Claussen – Adair County Health System
- Jane Ernst – Adair County Health System
- Steve Johnson – Broadlawns Medical Center
- Bob Schlueter – Iowa Department of Human Services
- Jen Stout – EveryStep
- Craig Sumrall – MercyOne Newton
- Nate Thompson – Story County Medical Center
- Dr. Teri Wahlig – ChildServe

Remote health care, frequently referred to as telehealth, is proving appropriate for many, but not all, conditions. Telehealth includes a range of services such as remote physician appointments, provider questions, filling prescriptions, and even remote monitoring. Hybrid in-person and virtual health care delivery is also used successfully in situations where some, but not all, appointments can be done remotely (e.g., preliminary diagnosis, appointment follow-ups, etc.)

Patients get access to providers through their workstations and mobile devices. Those residing far from their providers, or have limited mobility, enjoy greater access to health care services via telehealth. Similarly, telehealth delivery becomes even more beneficial for patients needing specialist practitioners which are located far from the patient's home (e.g., rural residents visiting urban specialists).

Health care stakeholders quickly pointed to **improved outcomes and improved patient satisfaction** for certain conditions. Mental health providers, as a prominent example, encountered a significant decrease in their no-show rate to their appointments which in turn led to improvements in patient health. The reasons for the decrease in missed appointments range from easier transportation, reduced need for childcare, and increased privacy from being spotted at a clinic.

Providers also cited a benefit in seeing, with video, the social situations of their clients which lends additional context to diagnosis and treatment options. That said, providers warned they

often need to be able to access their patients in a confidential environment and this is not always possible in a home setting.

*'Patient satisfaction (with telehealth) was great - 87% reported better than expected and 89% felt their whole family benefited.'*

*'Our providers are warming up. Initial spotty service contributed to slow uptake. Appreciate being able to see into the social situation.'*

**Technology and connection limitations** have been an impediment to the success of telehealth in some client situations. Providers want to see their patients on video; however, some patients only have access to phones without video capabilities and the quality of video, for those with video-capable devices, varied considerably.

*'Equity is an issue - need video. In rural Dallas County, people needed to move to a certain spot to pick up a signal.'*

**Equity for patient care** is a frequently voiced concern for health care providers. Access to care is improved for those who are not digitally divided. However, care for those with lower cognitive abilities, lower technical skills, language barriers, and limited technology are disadvantaged from care. As the health system becomes increasingly reliant on telehealth, these issues will become more profound unless they are addressed.

*'We surveyed our patient population and only had 50% had video capable phones.'*

*'We are looking for partners to place video kiosks in locations where our clients frequent and feel safe.'*

**Telehealth will continue to grow** according to all stakeholders including patients, providers, administrators, and payers. 'Necessity was the mother of invention' as caused by the pandemic which served as the catalyst for urgent change. Based on recent experience, the benefits and limitations of telehealth are better understood and accepted.

Nearly all providers and administrators expressed concern whether telehealth reimbursements will continue after the emergency COVID-19 rules are phased out. It appears to stakeholders that telehealth will be increasingly relied upon but will be paced by the availability to get paid for services rendered.

*'Telehealth is a convenience thing, the genie is out of the bottle, (we) can't go back. As a single father, this is a good thing.'*

*'We are opening up some more (payment) codes to telehealth but also still need more long-term outcome data.'*

## K-12 Education

### Participants

- Robert Bledsoe – Des Moines Public Schools – Network Architect
- Brad Bucks – Waukee Community School District
- Leslie Christensen – Waukee Community School District – Social Worker
- Deron Durlinger – Van Meter Community School District - Superintendent
- Tim Geyer – Norwalk Public School District
- Amy Harmsen – Marshalltown Community School District – IT Director
- Terry Hurlburt – Waukee Community School District
- Dan Warren – Des Moines Public Schools – Director of Technology
- Shane Wheeler – Newton Community School District
- Michael Wright – Earlham Community Schools

Primary and secondary educators (K-12), their institutions, the students, and the families they all serve had to make tremendous adjustments in a very short time as schools shifted to an online model nearly overnight. Not only did the participants have to carry the load, so did the internet.

Aside from the challenges associated with the new learning models, **bandwidth limitations were the largest impediment cited by educators**. Many families did not have a connection, were relying on a hotspot, or otherwise had inadequate speed or reliability for online learning. Connection issues were particularly acute for synchronous learning.

School officials noted **many households simply did not have a broadband service available** to them. The lack of a broadband providers impacted not only those in rural areas, but also communities in new developments close to towns and cities.

*'[Provider X & provider Y] could not keep up with working parents, school, work, gaming, streaming. Speed was throttled.'*

*'The community could tell at 9:15 when all the students signed onto Zoom... (business) meetings were scheduled to avoid these times.'*

*'Our school district has a large rural population and there are lots of people without a connection.'*

*'We provided a hotspot to one in four of the families in our district.'*

**Inadequate technology at home was a challenge for families and schools.** Throughout the pandemic, schools were expeditiously distributing technology and often had to provide more than one modem or workstation to a household to get them to an acceptable level. A few school districts reported having a highly transient population which exacerbated the process of maintaining a consistent connection.

*'Lots of families didn't have enough technology for the entire family.'*

*'I was charged with giving safe, secure remote access to 40+ thousand people; no small task.'*

*'People in \_\_\_\_\_ are transient which made it difficult to keep them equipped and connected.'*

As schools plan to return to normal schedules in 2021/2022 and with educators and families having experienced the benefits from e-learning tools, **schools intend to utilize online learning tools at increased levels** compared to pre-pandemic.

*'We put 12k devices in kids' hands, we're now 1:1. In 2021/22 we'll be refining processes and training teachers. We'll continue some hybrid courses.'*

*'If students have [broadband] access and the technology, they can take advantage of more classes.'*



## Higher Education

### Participants

- Christopher Brees - Iowa Valley Community College District
- Kim Didier – Des Moines Area Community College
- Mike Mosher - Iowa Valley Community College District
- Dave Robinson - Grinnell College
- Lee Weers - Central College
- Tim Wheeldon - Grand View University

Central Iowa is home to many higher education learning institutions ranging from private colleges to public universities. Many universities have a large resident population who enjoy robust connectivity on campus whereas the participant schools of this focus group have a higher percentage of students residing off campus.

None of the institutions participating in the focus group reported significant problems with their on-campus networks during the pandemic.

However, **bandwidth for many remote students, particularly rural students, was inadequate** or non-existent. Connections for remote instructors and school staff also posed challenges. Personal hotspots were frequently not a sustainable solution for students because of cell data limits and throttling.

*'Music lessons and high-end performing arts couldn't be performed without better internet.'*

*'Few students are using personal hotspots due to data limits.'*

*'Purchased hotspots for hundreds of students.'*

**The uneven access to broadband resulted in the inequitable distribution of education.**

*'Many students (are) not in town. Those out of town struggled significantly – including staff. What failed is consumption of content.'*

*'If connections go down, learning is lost.'*

*'For some students who are foreign .... many couldn't get BB service contracts given their (lack of residential) longevity.'*

## Conclusion of Stakeholder Meetings

The research team is grateful to the individuals who took the time to participate in the focus group sessions. These leaders from agriculture, business, education, and health care shared robust insights into the current state of their industries and trends that will shape their future needs for broadband infrastructure.

For agriculture and business leaders, broadband is essential for optimizing their daily operations as they can leverage global sales channels and real-time data management. Moreover, they are able to access a wider pool of talent through remote work arrangements to those who prefer a rural lifestyle.

Through enhanced access, health care leaders noted the benefits of telehealth in terms of improved outcomes and improved patient satisfaction. Similarly, having experienced some of the benefits of e-learning, educators shared intentions to continue utilizing some online tools into the future. Additionally, there is recognition that some learners thrive in an online environment in which they can learn at their own pace with fewer distractions.

However, the benefits of broadband are not yet evenly available throughout the 11-counties Central Iowa Study Area (CISA). Access, bandwidth limitations, and reliability were frequently mentioned as factors limiting our collective ability to leverage the economic, health, and learning benefits that are possible through digital channels. Until reliable and affordable high-speed broadband is available to all, the digital divide will continue to limit equity and prosperity across the region.

## Public Sector Meeting

It is also important to determine if the public sector communications needs are being met. Zoom meetings were arranged from May 7 - 12, 2021, to understand current needs of public entities, whether those needs are currently being met and if it appears current capacity and speeds will meet future plans. The groupings of these meetings included:

- Public Works and Utilities
- EMS and First Responders
- County and City Administration
- Economic Development

The rough outline of a guiding agenda for the meetings was:

- Provide update to participants
- Discuss:
  - Their current connectivity in the office and in the field (if applicable)
    - Is their connectivity adequate for their current needs?
    - What are they currently using connectivity for?
    - What are they currently paying (if they don't mind sharing that and having it in a report)?
  - Their future needs
    - Do they have plans or possibilities for future applications?
    - Do they anticipate their current connectivity being able to support those possibilities?
    - Will connectivity impede any future steps or growth?

### Public Works and Utilities

The results from the Public Works and Utilities participants were as follows.

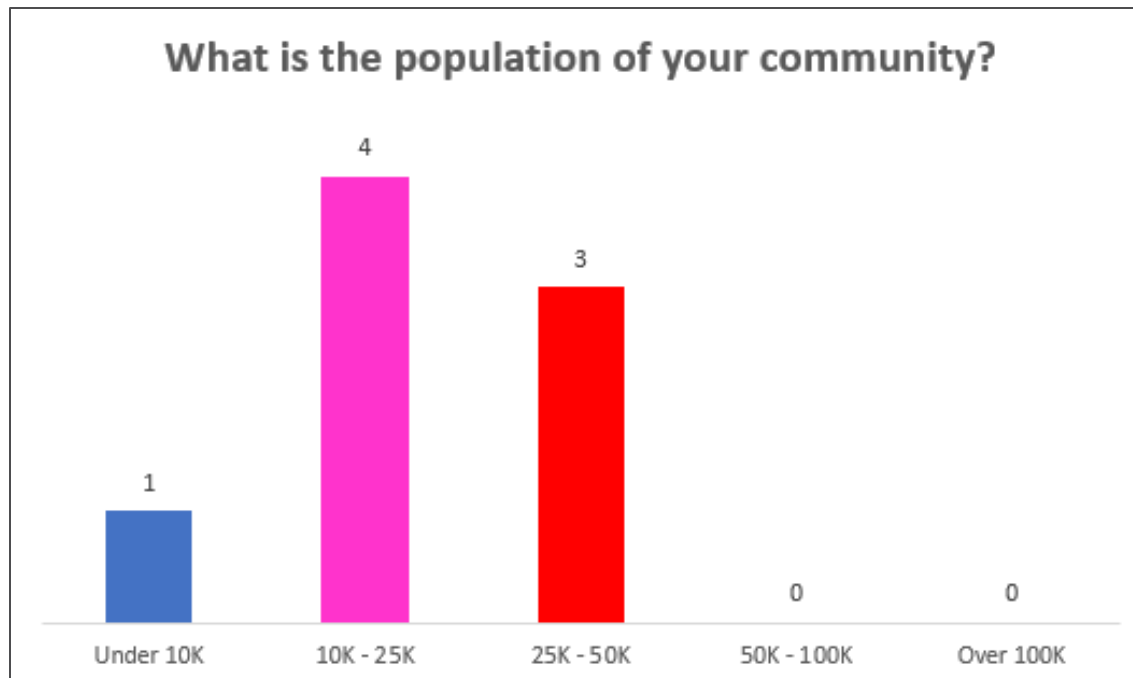

This was a good representation of different size organizations within the 11-county study. The sizes of the public entities would also provide some insight into the impacts of size on connectivity.

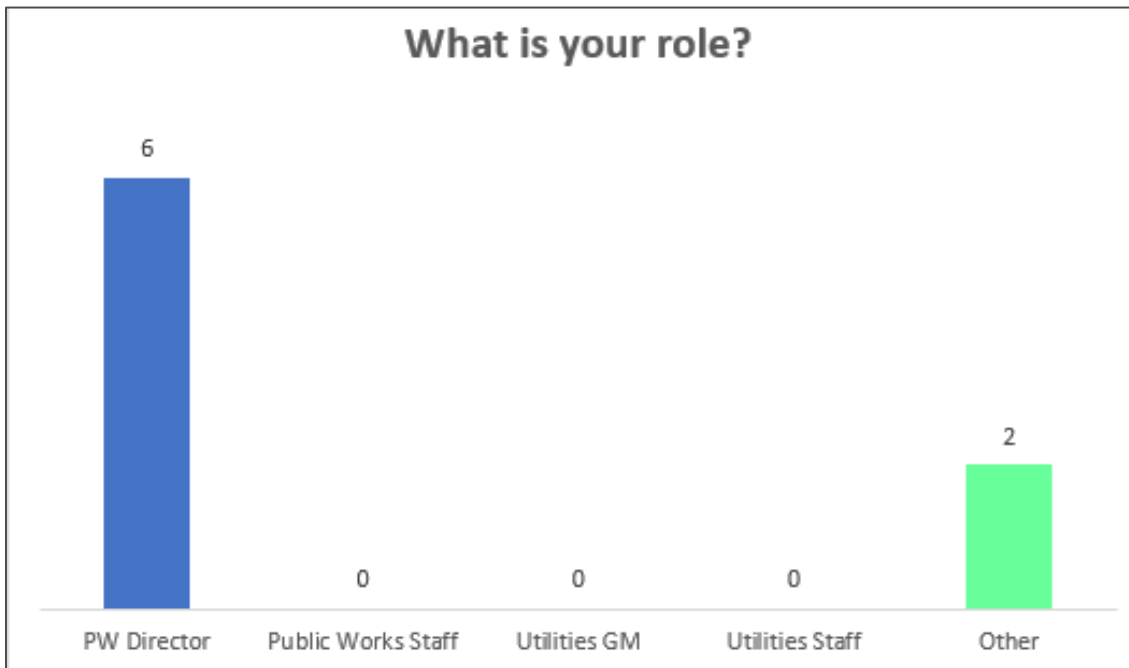

Whether their offices and buildings were connected roughly corresponds with the size of the community.

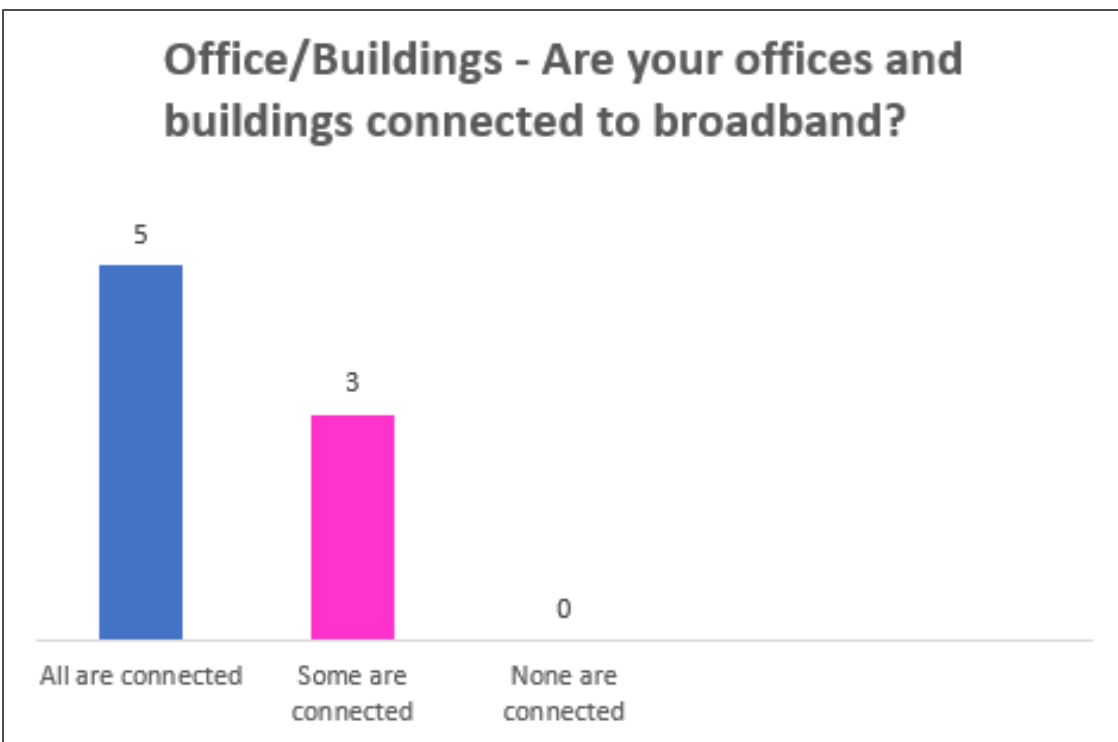

A pleasant surprise in the meetings with Public Works and Utilities leaders was the amount of buildings that are connected by fiber.

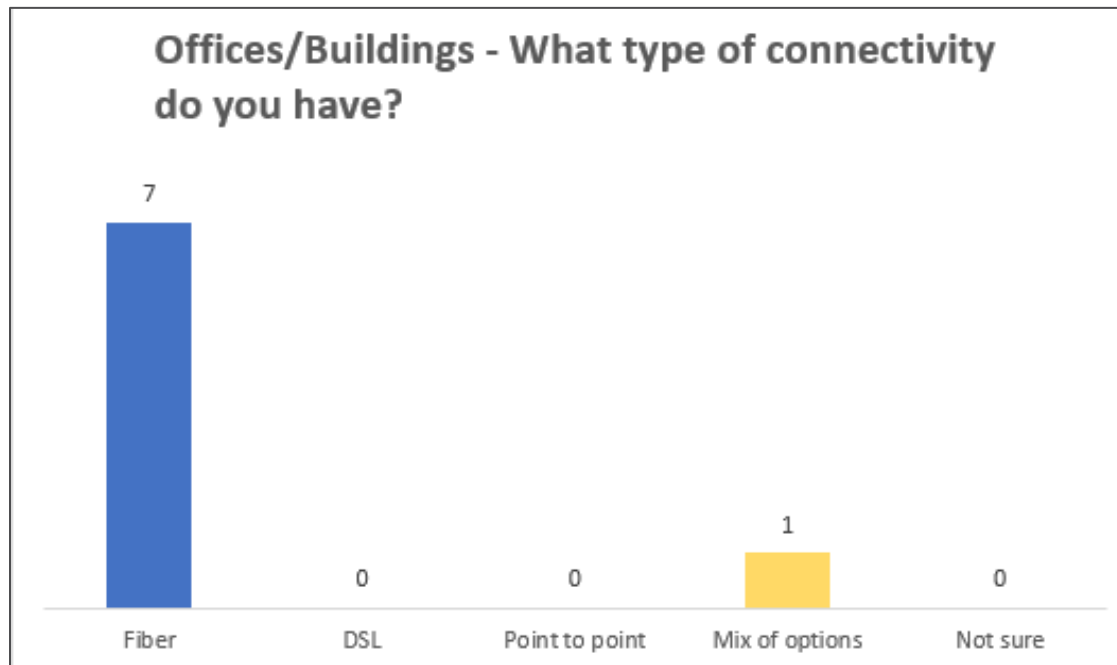

Given the amount of fiber connectivity for the buildings within the group in this meeting, the corresponding level of satisfaction for current needs being met was predictable.

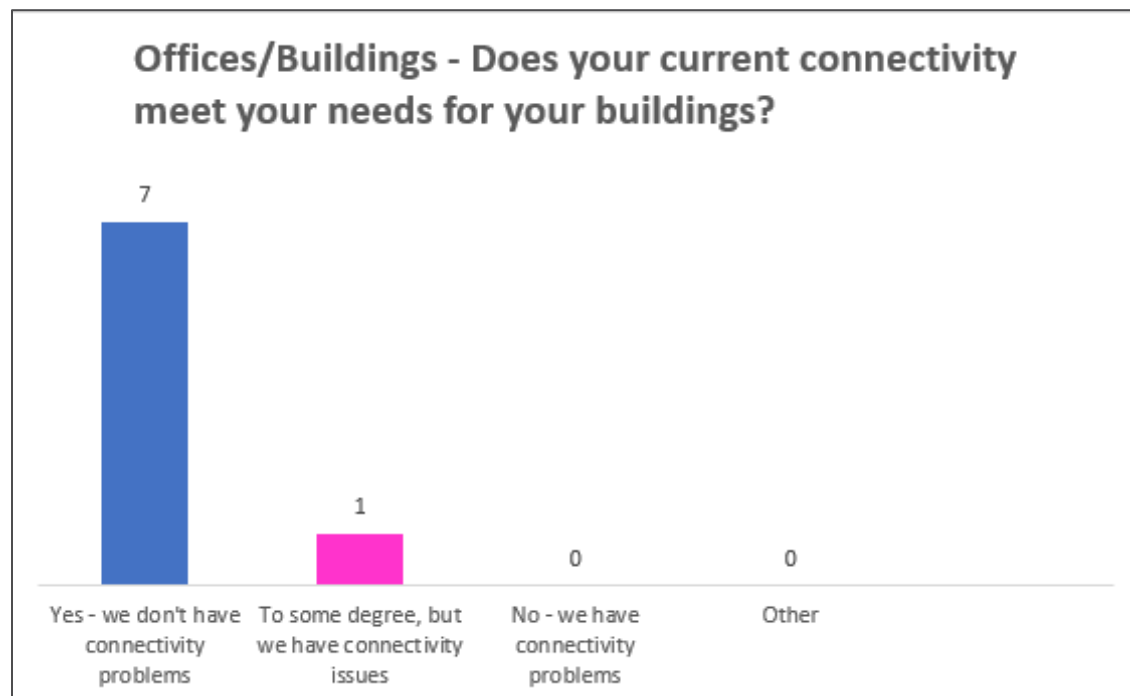

Fiber provides good connectivity as far as capacity and speed, but the study group indicated a concern in their present circumstances: redundancy. This can happen for several reasons, usually due to costs, but it poses a risk for uninterrupted operations, particularly in emergency situations.

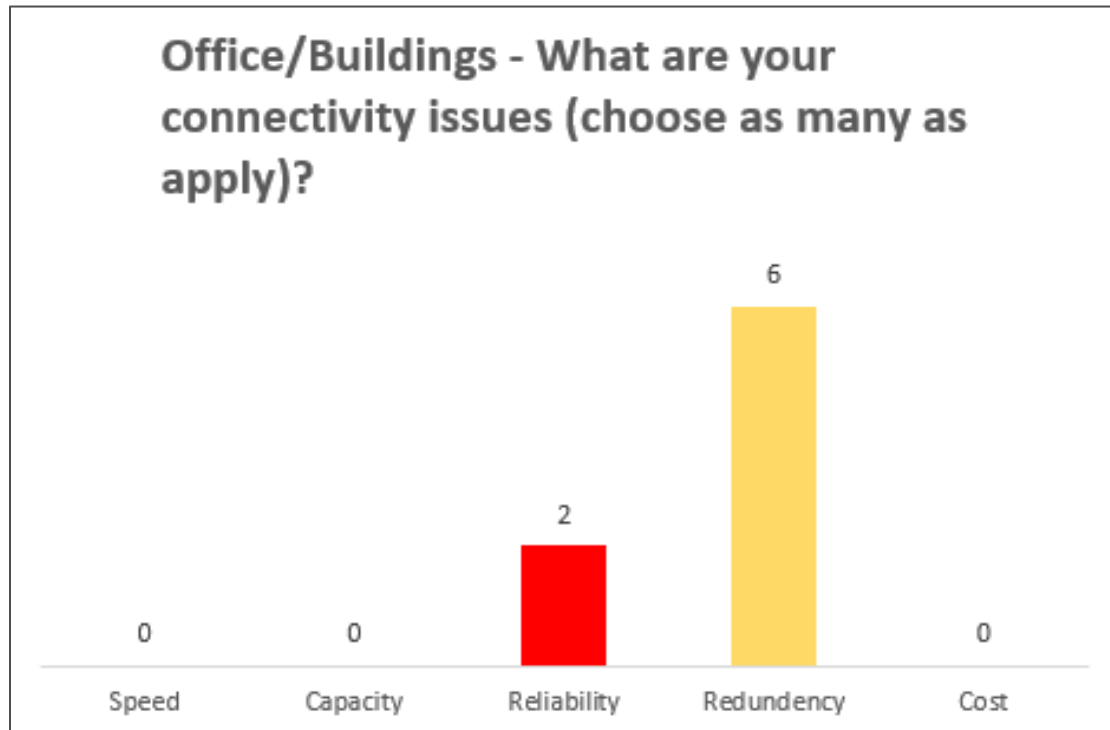

Another concern of the leaders in the Public Works and Utilities public sector meeting was connectivity of some of their other assets.

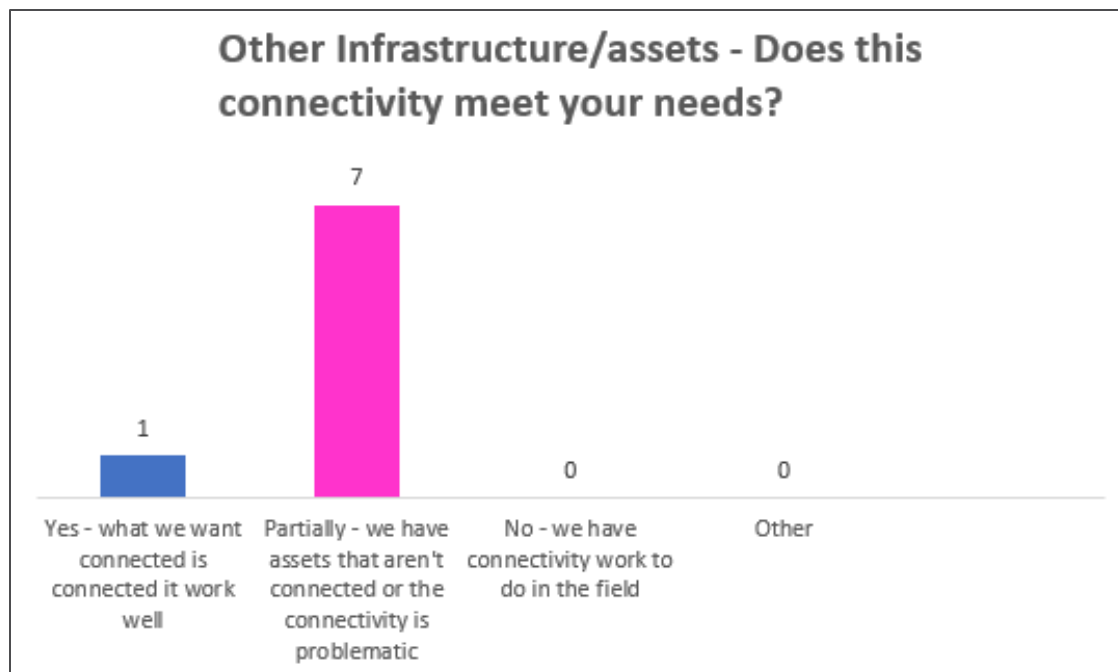

One of the most striking results in this meeting was regarding future needs.

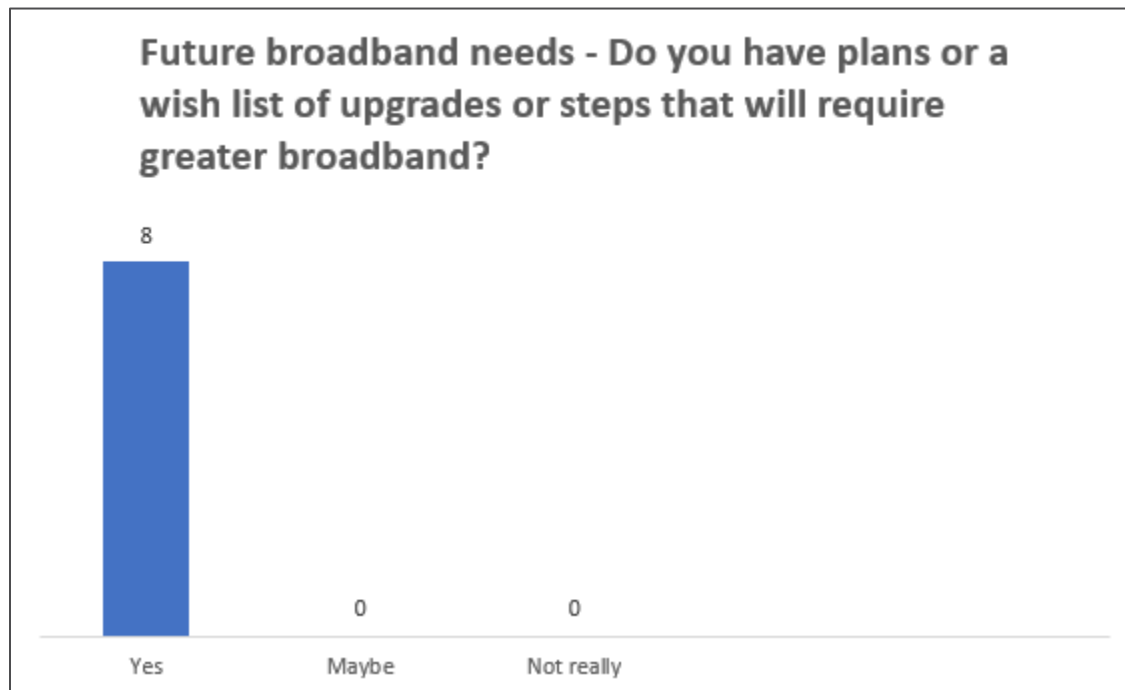

This response underscores the need to continue to evaluate the future capabilities of connectivity, including fiber.

With the expectation there will be future needs that will require increased capacity, the Public Works officials indicated a possible concern if their broadband does not improve, they might not be able to make some of the improvements they feel they should.

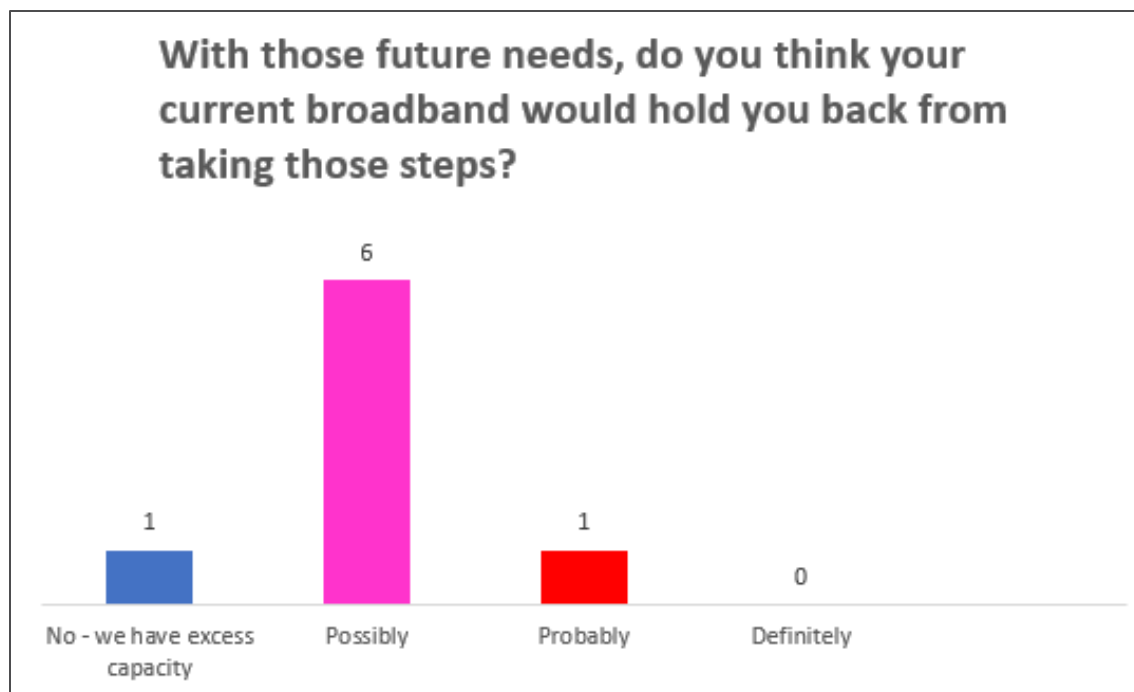

Another Public Works issue is Right of Way (RoW) availability. RoW is a limited asset that can become congested from natural limitations (steep banks, wetlands, etc.) and multiple utilities. Water, wastewater and electricity typically only have one run of infrastructure. Telecommunications can have as many runs as there are providers who deploy infrastructure – and there are some providers who run multiple lines in some areas.

When there are natural issues or multiple providers, RoW can become limited, and in extreme cases, communities can run out of available RoW. That can become a public safety issue.

Communities that do not have RoW congestion issues and also need better connectivity can use their RoW and permitting to encourage providers to deploy fiber through preferred routes, streamlined permitting, collocation, etc. More information about using and protecting RoW can be found in the Permitting Section of this report.

One telecommunications trend that could require significant amounts of RoW is 5G. This technology requires multiple cells, most of which will have fiber run to them. Every provider placing 5G will require their own fiber line to the cells. That will consume RoW.

In the graph below, the participants in this group indicated a concern that RoW congestion could be a problem in their community. In the following graph, a surprisingly high number of the participants have already started to receive permit requests for 5G related infrastructure.

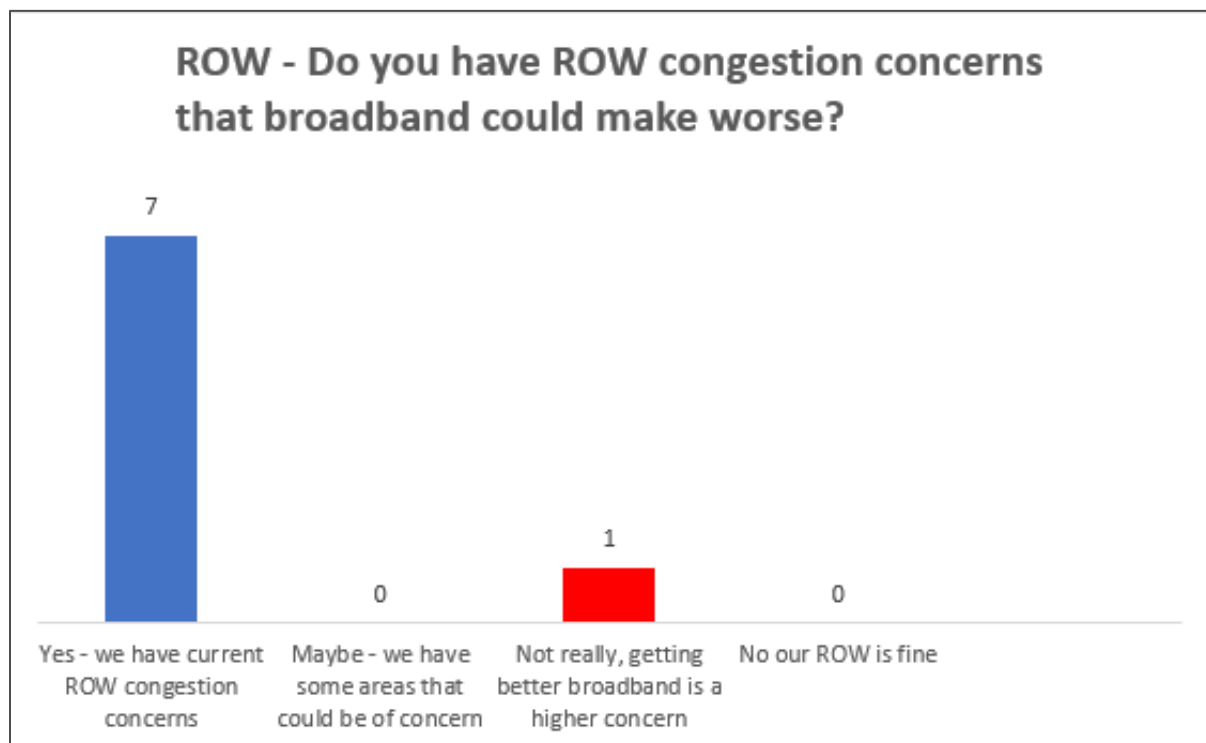



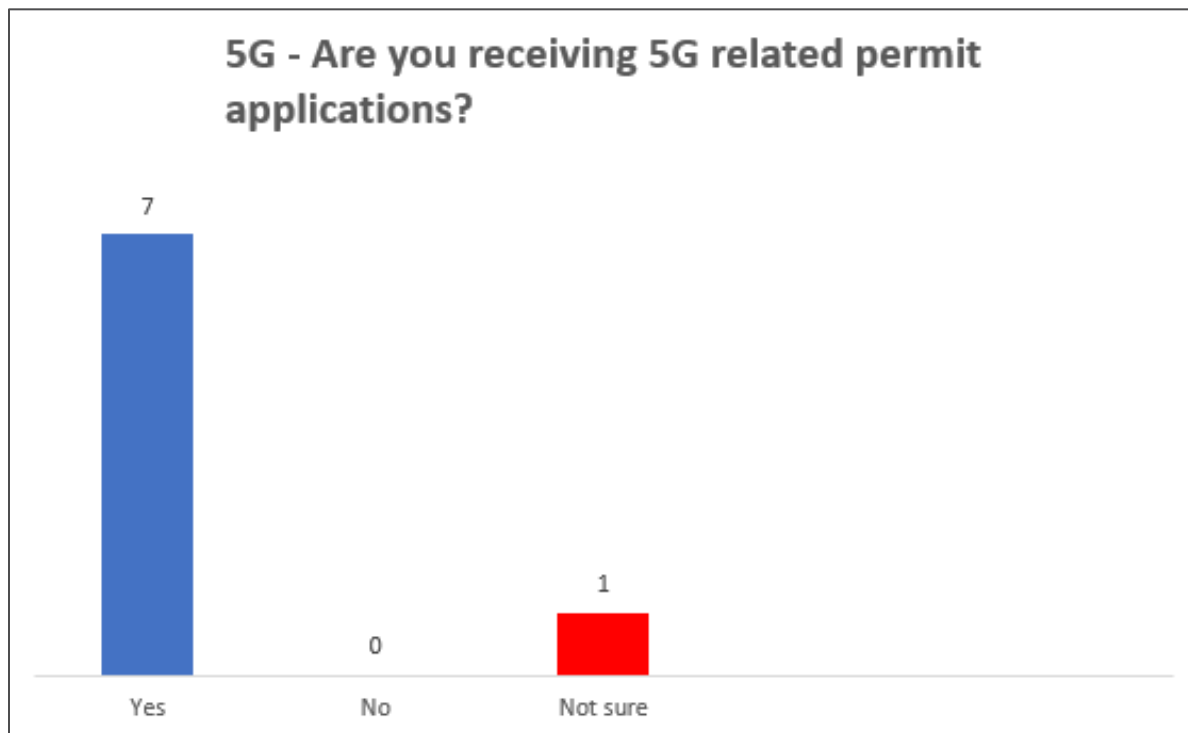

## Public Engagement Topical Meetings

Four topical public meetings were organized over Zoom to discuss broadband related topics among a panel and with the public. These were recorded and could be seen on The Partnership’s website.

- The Rural Broadband Experience
- The Challenges of Learning from Home
- Getting Care from Anywhere – Telehealth in Central Iowa
- Remote Work Challenges and Opportunities

There were not any major surprises in these meetings, but they did confirm the challenges faced by different segments of Central Iowa.

## The Rural Broadband Experience

Thursday, May 6, 2021

While some rural residents in Central Iowa enjoy excellent broadband, others struggle to connect. This session explored why there are broadband challenges in rural areas and discussed ways to solve those challenges. The full discussion can be viewed at:

<https://www.dsmpartnership.com/news-media/blog/central-iowa-broadband-survey-the-rural-broadband-experience>

## Panelists

- Bill Menner, Iowa Rural Development Council
- Brittany Morales, Iowa Area Development Group
- Brent Kelso, Rural Warren County (recorded)
- Tar Marcias, Holalowa (recorded)
- Tom Leners, Madison County Development Group

## Talking Points

- What do we mean by “rural”?
- What are the gaps?
  - Some rural areas lack any quality connection option.
  - Others only have one option.
  - Wireless and other reliability challenges.
- What impacts have lack of broadband had on the rural economy? What specific sectors have been impacted the most (i.e., agriculture, retail, etc.)? Are these speed issues, concurrent use issues, cost issues?
- What impact will Starlink have? Discuss Starlink’s promises and likely limitations.
- How has broadband access and quality affected Iowa’s Latinx community (interview with Tar Marcias)?
- Is poor broadband in rural areas causing people to move to seek better options? Or do people consider it just part of the rural experience?

There were not many surprises concerning the challenges by rural businesses and citizens regarding broadband. Participants discussed the barriers to extending broadband to rural Central Iowa and the steps they have taken to try to find the best broadband they could (e.g., point-to-point, cellular, etc.).

## The Challenges of Learning From Home

Thursday, May 6, 2021

During the past year, many students were forced to learn remotely and that has raised issues in Central Iowa. Student connectivity has been impacted by internet availability, reliability and affordability. This session explored how these issues impacted learning, ways parents and students have coped with these limitations, and how filling central Iowa's broadband gaps can help remote learning into the future.

The full discussion can be viewed at: <https://www.dsmpartnership.com/news-media/blog/central-iowa-broadband-survey-the-challenges-of-learning-from-home>

## Panelists

- Greg Ebeling, Superintendent, Pella Community Schools (recorded)
- Kendra Alexander, Director of Student Services, Winterset Community Schools District
- Izaah Knox, Urban Dreams

## Talking Points

- K-12: How was remote learning on the radar screen before the COVID-19 pandemic?

- K-12: When COVID-19 is behind us, what role will remote learning have moving forward?
- K-12: What types of instruction have been most reliant on (and impacted by) broadband (e.g., live streaming the classroom, watching videos, etc.)?
- Higher education has already been using online learning for years for some students. Was there shock to the system when all instruction was forced online?
- Will colleges be investing more to enrich the online learning experience? Will lack of high-speed options impact access to the opportunity to have flexible education?

The panelists discussed there were connectivity issues before the pandemic, but the pandemic created the situation of needing to have the necessary hardware and internet to have the necessary remote education. At both the high school and collegiate level, schools worked to provide laptops, but still had to figure out how to connect those with either access or adoption challenges. In an eye-opening example, the Carroll County School District had been providing 54 hotspots for remote connectivity compared to the first year of the pandemic, where they increased from the 54 hotspots to 459. That underscores both the creativity of the educators and the access and adoption need of students.

## **Getting Care from Anywhere – Telehealth in Central Iowa**

Monday, May 10, 2021

For many Central Iowans, their first experience with telehealth was during the COVID-19 pandemic, when in-person access to health care was somewhat limited. But telehealth is here to stay as it lowers costs and improves access for patients. This session discussed how telehealth is impacting the lives of persons in the area and how it will continue to evolve.

The entire discussion can be viewed at: <https://www.dsmpartnership.com/news-media/blog/central-iowa-broadband-survey-getting-care-from-anywhere>

### Moderators

- Curtis Dean, SmartSource Consulting
- Todd Kielkopf, Kielkopf Advisory Services

### Panelists

- Katie Wingert, Broadlawns Medical Center
- Kay Vanags, Aging Resources of Central Iowa
- Benjamin Lefever, Certintell Telehealth

### Talking Points

- What do we mean by telehealth? Discuss the different forms this can take, from full video virtual visits to electronic exchange of doctor-patient communications.
- What trends have telehealth providers experienced before and during the COVID-19 pandemic?
- What is expected to happen after the pandemic?

- What kind of connectivity is needed to provide a quality telehealth experience, both from the provider’s perspective and the patient?
- Are there any examples you can share where poor broadband or the lack of a broadband connection prevented the delivery of telehealth services?
- What new types of telehealth would be possible with universally available, high-capacity broadband services?
- Discuss ambient technologies to detect falls, breathing, etc. that impact the ability to stay in homes longer in life.

As the panelists stated, telehealth is not going away. Even with that reality, there are connectivity issues facing telehealth, ranging from security of data (HIPAA), whether the broadband on the patient side is suitable for telehealth, if patients understand the technology, do health care providers have adequate broadband for consultations, etc.

## Remote Work Challenges and Opportunities

Tuesday, May 11, 2021

While COVID-19 introduced many Central Iowans to remote work for the first time, others have been working from home for years. Remote work will continue to grow as work becomes less of a place you go and more of a thing you do. This session explored the impact of broadband connectivity on the ability to work remotely. How remote work opportunities are helping many Iowans supplement their incomes, allowing them to benefit from the digital economy was also explored. The vital role broadband plays in entrepreneurship in Central Iowa was also discussed.

To view the full discussion, follow this link: <https://www.dsmpartnership.com/news-media/blog/central-iowa-broadband-survey-remote-work-challenges>

### Moderators

- Curtis Dean, SmartSource Consulting
- Todd Kielkopf, Kielkopf Advisory Services

### Panelists

- Staci Hupp Ballard, Iowa Economic Development Authority
- Ben McDougal, Author and Entrepreneur
- Dave Tucker, NextLevel Ventures
- Dr. Marvin DeJear, Greater Des Moines Partnership

### Talking Points

- Discuss the importance of reliability when working remotely.
- Speed: How much is enough?
- Are upload speeds becoming more important? Give some examples of what applications require high upload speeds.

- Discuss how public spaces (e.g., restaurants, libraries, coffee shops, etc.) have been forced to fill the gaps by providing places for people to work when their home internet goes down.
- What complaints do you hear most about broadband deficiencies related to trying to make an income or save expenses based on having reliable high-speed connectivity?
- How do you think these are changing and impact access to economic opportunities across various demographics in Central Iowa?

The necessity to be able to work from home during the pandemic showed the challenges faced by employers to have the needed infrastructure and the necessary policies and practices. The pandemic also highlighted the connectivity challenges faced by employees. The ability to work from home has made the workforce more mobile (many able to work from anywhere), so communities could work towards being the employer of choice. Panelists discussed more employees will be returning to offices, but given the proliferation of working from home, many employers and employees might create mixed schedules in which employees work some from home and some in an office.

## Provider Engagement

From the inception of this project, private providers were a key ingredient in the success of improving broadband in Central Iowa.

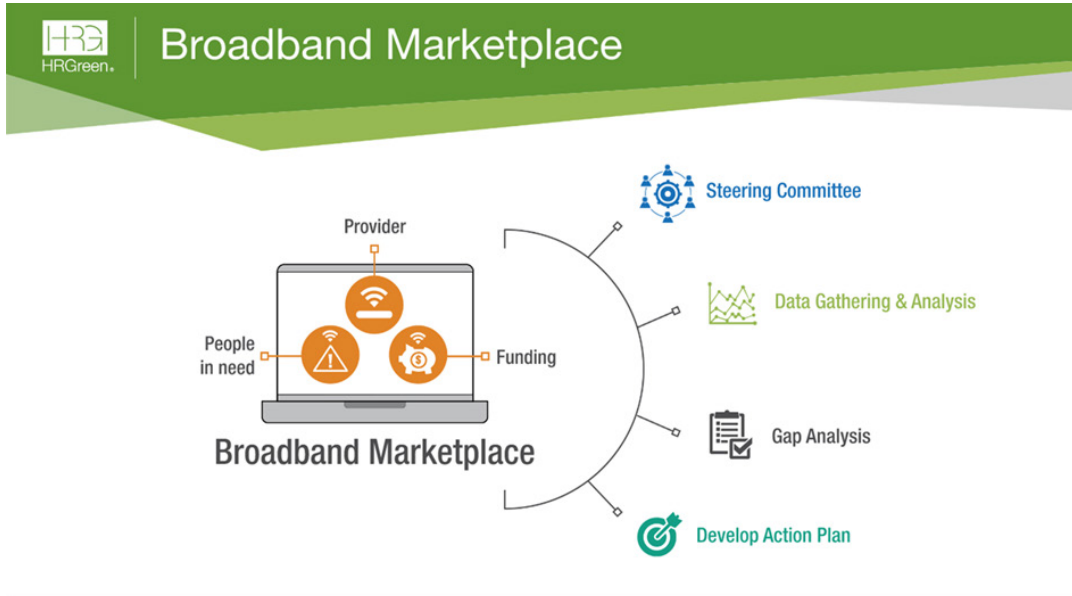

Figure 11 - Broadband Marketplace

In the Broadband Marketplace concept, private providers are one of the three legs of the stool that work together to improve broadband (along with understanding the connectivity needs that exist and arranging for funding).

As part of the project, several steps were taken to develop relationships and work as closely with providers as possible.

## Identify Providers and Conduct Meetings

Three meetings were conducted with the area providers:

AT&T	MetroNet
Aureon	Midlowa Net
Barnes City Cooperative Telephone	MiFiber
Brooklyn Mutual Telephone Coop	Minerva Valley Companies
BTWI	Miniburn Communications
Casey Mutual Telephone Company	Nextlink
Central Iowa Satellite	Ogden
CenturyLink/Lumen	OmniTel
Colo Telephone Company	Panora Teleco Wireless
ConnectPoint	Partner Communications Cooperative
Consolidated Communications	Reasnor
Coon Valley Cooperative Telephone Association, Inc.	Rise Broadband
Cumberland Telephone Company	SCC Networks
Heart of Iowa Communications Cooperative	Stratford Mutual Telephone
HughesNet	Sully Telephone Association Inc.
Huxley	Teknix Internet
ICS Advanced Technologies	Unite Private Networks
Imon Internet	US Cellular
Indianola Municipal Utilities	Verizon Business
ITC Midwest	Verizon Wireless
Lynnville Telephone Company	Viasat Internet Provider/Excede Satellite
MCG	WesTel
Mediacom Communications Corp.	Windstream

## Introductory Meeting with Providers

An introductory provider meeting was held in June 2021. This meeting was to introduce the project to the providers in the 11-county area and to present the concepts needing their input.

## Immediate Opportunity for Broadband Funding – July 9, 2021

During the process of this study, the State of Iowa opened NOFA #6. This is discussed further in the Grant section below. As a summary, the State received applications to award \$97,500,000 in grants for broadband in Iowa.

Because this study was underway, The Partnership and HR Green decided to focus on this grant opportunity to synthesize and provide relevant information that had been developed to providers. A Zoom meeting was held July 9, 2021 to distribute survey data, cost data and information about the grant.

The State determined tiers of eligibility. The concept was people with greater broadband need would be given a higher percent of grant (meaning the provider would have to provide less matching funds). The below map shows the State tiers by color and the number of parcels in each county in each of those tiers.

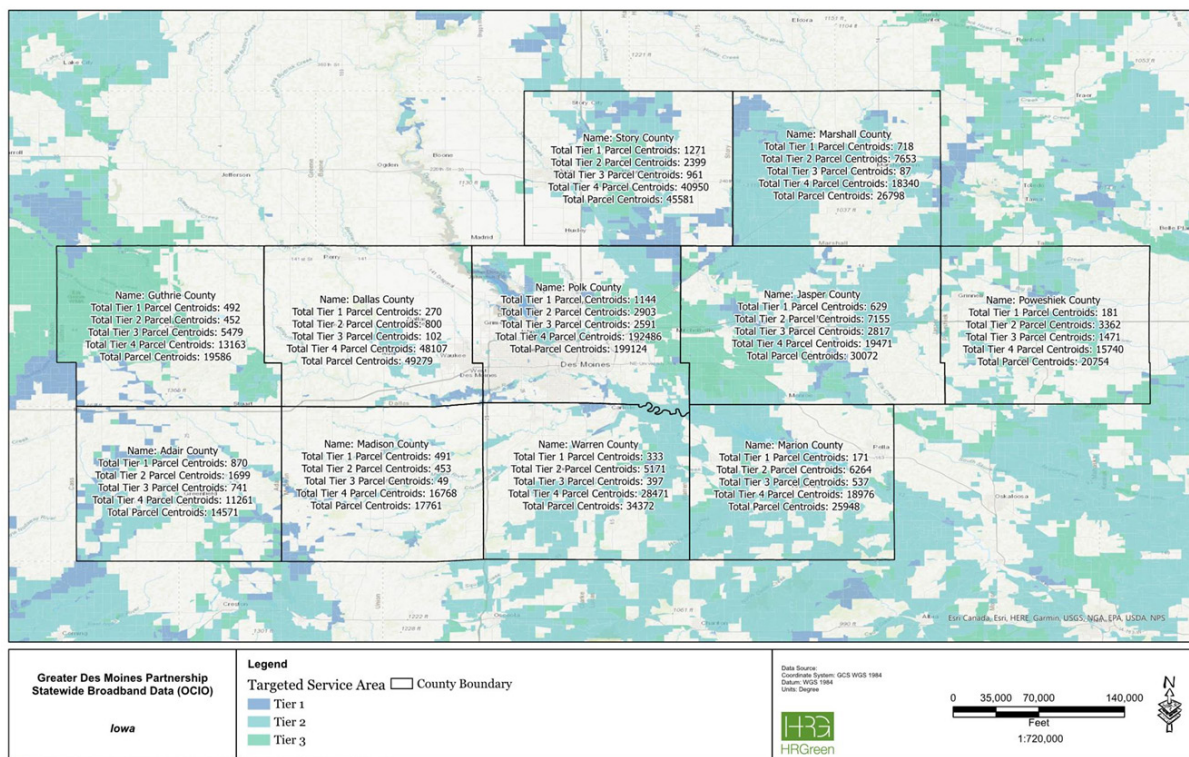

Figure 12 –Statewide Broadband Data

This was presented to the providers to give them a specific reference to how much need (and, thus, grant money available) there is in a county they might be interested in deploying assets.



With that baseline of need, costs were determined per parcel. This is a complex calculation because:

- Different technologies could be deployed
- There could be multiple parcels in an address
- It was not possible to know how far a provider would have to deploy middle mile to reach the eligible parcels.

To offset those variables, the higher cost possibility was used. Therefore, the costs determined represent underground fiber. Fiber was calculated to each parcel (if there were multiple parcels in one address, only that one address would need fiber). Middle mile was assumed to be an average higher distance than would be necessary.

With those assumptions, the following calculations were made to develop costs per parcel.

Number of parcels per county in each Tier.

County	Tier 1 Parcels	Tier 2 Parcels	Tier 3 Parcels	Tier 4 Parcels	All Parcels
Adair	870	1,699	741	11,261	14,571
Dallas	270	800	102	48,107	49,279
Guthrie	492	452	5,479	13,163	19,586
Jasper	629	7,155	2,817	19,471	30,072
Madison	491	453	49	16,768	17,761
Marion	171	6,264	537	18,976	25,948
Marshall	718	7,653	87	18,340	26,798
Polk	1,144	2,903	2,591	192,486	199,124
Poweshiek	181	3,362	1,471	15,740	20,754
Story	1,271	2,399	961	40,950	45,581
Warren	333	5,171	397	28,471	34,372

County	Average Cost Per Subscriber
Adair	\$ 15,028.00
Dallas	\$ 11,244.34
Guthrie	\$ 12,785.04
Jasper	\$ 12,785.04
Madison	\$ 12,785.04
Marion	\$ 12,785.04
Marshall	\$ 12,785.04
Polk	\$ 12,785.04
Poweshiek	\$ 14,159.62
Story	\$ 12,237.50
Warren	\$ 11,218.56

Knowing the number of parcels, a high-level design was created for each county until an average per county (with similar populations) became clear. With those averages, a cost per parcel was developed.

When the grant awards were released, a cost per address was included. This was address verses parcel and an actual bid number on specific addresses, but the numbers showed the calculations presented in this provider meeting were high, but within a reasonable margin (depending on technology) as was desired.

With an average cost per parcel, calculations could be done to show how much grant money was available for all of the eligible tiers in the 11-county study area. The numbers showed the magnitude of the need. It also showed even if all of the State grant money was applied to the

needs in Central Iowa, there would still be needs that were not covered. This table identifies the order of magnitude if all parcels were built to (including those not eligible for grants, which currently show as served). This scale is important because of the question as to whether the parcels shown as served truly are served.

County	Approximate Cost with Grants	Approximate Costs without Grants	Approximate Potential Savings with Grants
Adair	\$ 195,699,908.12	\$ 218,973,024.17	\$ 23,273,116.04
Dallas	\$ 548,107,787.22	\$ 554,110,017.94	\$ 6,002,230.72
Guthrie	\$ 200,413,764.29	\$ 250,407,733.48	\$ 49,993,969.19
Jasper	\$ 313,312,672.23	\$ 384,471,630.82	\$ 71,158,958.59
Madison	\$ 222,202,663.49	\$ 227,075,041.07	\$ 4,872,377.58
Marion	\$ 286,694,225.32	\$ 331,746,138.49	\$ 45,051,913.16
Marshall	\$ 290,673,568.07	\$ 342,613,419.88	\$ 51,939,851.82
Polk	\$ 2,502,061,773.74	\$ 2,545,807,695.38	\$ 43,745,921.64
Poweshiek	\$ 255,887,056.64	\$ 293,868,831.40	\$ 37,981,774.76
Story	\$ 531,586,089.27	\$ 557,797,595.60	\$ 26,211,506.33
Warren	\$ 352,769,908.78	\$ 385,604,394.46	\$ 32,834,485.68

This points out the need for grants, but it also points out the need for more State grants, Federal grants and other sources of funding.

To focus on the costs for parcels that were deemed unserved or underserved, the numbers are:

County	Cost Per Parcel	Tier 1 Parcels	Tier 1 Cost Per County	Tier 2 Parcels	Tier 2 Cost Per County	Tier 3 Parcels	Tier 3 Cost Per County	Total Costs Per County
Adair	15,028.00	870	13,074,360	1699	25,532,572	741	11,135,748	49,742,680
Dallas	11,244.34	270	3,035,972	800	8,995,472	102	1,146,923	13,178,366
Guthrie	12,785.04	492	6,290,240	452	5,778,838	5479	70,049,234	82,118,312
Jasper	12,785.04	629	8,041,790	7155	91,476,961	2817	36,015,458	135,534,209
Madison	12,785.04	491	6,277,455	453	5,791,623	49	626,467	12,695,545
Marion	12,785.04	171	2,186,242	6264	80,085,491	537	6,865,566	89,137,299
Marshall	12,785.04	718	9,179,659	7653	97,843,911	87	1,112,298	108,135,868
Polk	12,785.04	1144	14,626,086	2903	37,114,971	2591	33,126,039	84,867,096
Poweshiek	14,159.62	181	2,562,891	3362	47,604,642	1471	20,828,801	70,996,335
Story	12,237.50	1271	15,553,863	2399	29,357,763	961	11,760,238	56,671,863
Warren	11,218.56	333	3,735,780	5171	58,011,174	397	4,453,768	66,200,723
			84,564,337		487,593,418		197,120,540	769,278,295

In this graph, the total construction costs to build to all of the parcels for all 11-counties is \$769,278,295. This, again, shows the need for grants to help offset this large number of costs.

It is important to note that the Technology Plan recommendations in this study do not call for the deployment of fiber optic solutions as the preferred alternative. Matching appropriate technologies to urban, suburban, rural and remote geographies should be a core principle of Central Iowa's broadband marketplace. Fixed Wireless technologies are a likely solution in many of the rural and remote areas in the region and such solutions can be deployed at a significant discount to the fiber costs above. Further, LEO satellites may provide a useable alternative for some remote areas, which are undoubtedly driving the cost per passing costs used in this data due to their low population densities and higher cost of deployment.

The second provider meeting also addressed appealing areas that the survey showed did not have as good of coverage as the State map showed (areas that were not shown as eligible, but the survey showed had broadband needs).

The example of the Madison County speed test map shows this discrepancy.

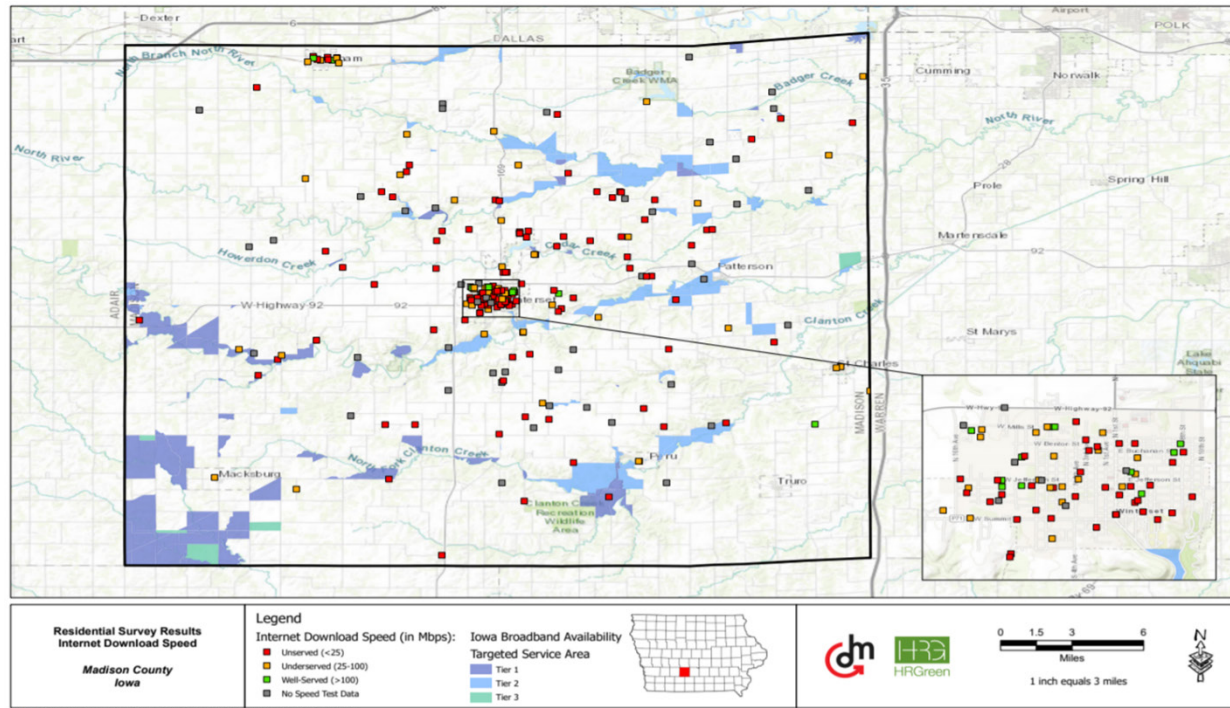

Figure 13 – Madison County Speed Test Map

The areas with red dots that do not have dark blue, light blue or green shading behind them are not eligible. This could be appealed to the State to have these areas possibly declared eligible for grants. If that is not done for NOFA #6, it might make sense to work on improving the State and FCC maps for future grant cycles.

Also, a heat map was developed that showed areas with the most speed test depicted need that were not listed as eligible for grants across the entire study area. These would need to be further investigated to clarify needs, but this is what the survey data showed.

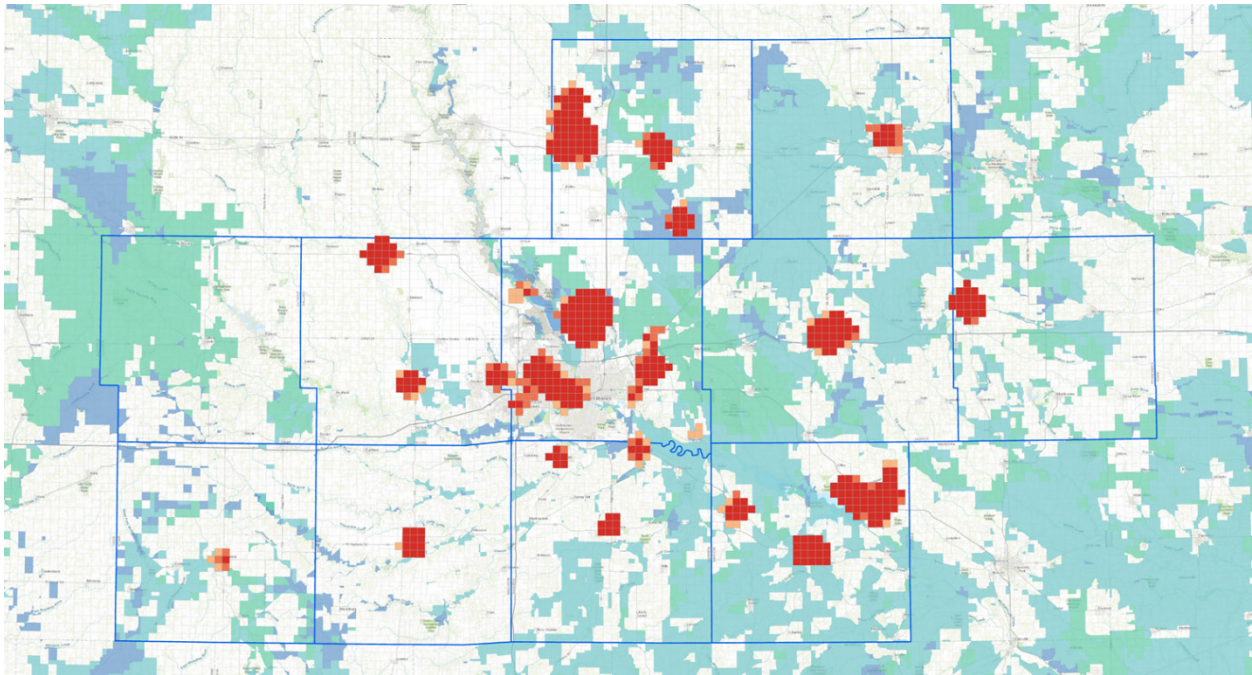

Figure 14 - Heat Map

The following takeaways were discussed at this meeting.

- There are areas that appear to be appealable – more data might be necessary
- It seems there are significant grant opportunities in the 11-county area. Analysis clearly verifies that assumption
- This methodology provides important information based on the data we have – down to the TSA level. To have this information be grant ready, it would be necessary to do a high-level design based on addresses on a TSA by TSA level. That could also produce a potential revenue number.
- Resources will be needed for this and subsequent grants (State and Federal), including high-level design and grant writing

## Policy

In the third provider meeting, HR Green provided an update on the project and the main focus was to discuss what policy recommendations the providers would have for the communities. Policy can have a significant impact on the costs to deploy broadband infrastructure – which can lead a provider to build in one area as opposed to another. In this provider meeting, the providers offered the following suggestions:

- Differing types of construction have significantly different costs. For example, if aerial placement is prohibited or boring is required
- Funds for new construction are limited, so the tradeoffs are to either have smaller builds, fewer service points, or move to other areas
- Related to rigidity on fiber placement, it is important to work together on where the fiber will go so that it is the most economical and meets real community needs. This can help a build go faster and be more affordable

- Having to move existing infrastructure can happen, but it is expensive and would be much better to plan ahead over the next few years. Then it could be possible to reduce the need for moves, saving funds that could apply to building out new infrastructure. The example was given of a provider putting in new service only to have to move a lot of it the next year because of a project that was planned, but not discussed with the provider
- If one community has requirements that increase costs, then it may make sense to build in a less expensive community
- Greater availability of municipal conduit: If conduit is available, providers would like to discuss terms to see if it will be a safe, less expensive way to deploy – they are open to those discussions, the details will be the deciding factor. Also, the providers would suggest having more than one conduit, given there are cost savings in multiple conduit builds. If conduit is going in, it is better to not run out of capacity and options in planning how to provide better service
- Speed to market matters: If communities have preferred paths that are faster to deploy, providers are willing to look at those (assuming the requests meet deployment plans)
- Long decision times, including those involving council meetings or State approval, can add months to a build schedule. Options like preferred paths that are already approved, or expedited processes can make a build more attractive
- Providers come to the table with pre-determined budgets to deploy new service. They want to work with counties and cities to make those dollars go as far as possible and to make the deployment process as predictable as possible, in everyone’s best interests.

Additionally, HR Green staff met with providers in specific counties in group meetings and in individual discussions, to address their specific questions.

## **Grant Opportunities**

Grant dollars for broadband will come from several sources. For example, during this study, the State of Iowa made available \$97.5 million for broadband grants in NOFA #6. The State will likely provide another round of funding either in 2021 or in 2022, and the governor has indicated her goal to make available \$450 million over the three-year period 2021 through 2023.

In NOFA #6, the following applications for grants were made with the notated awards:

Ace Telephone Association	\$12,165,592.49
Allamakee-Clayton Electric Cooperative, Inc.	Not Awarded
Alpine Communications, LC	\$3,292,078.84
Alpine Communications, LC	\$1,699,319.57
Alpine Communications, LC	\$5,468,428.29
Alpine Communications, LC	\$4,318,883.67
AMG Technology Investment Group, LLC	Not Awarded
Muscatine Board of Water, Electric, and Communications	\$547,148.47
BTC, Inc.	\$15,073,573.81
Butler-Bremer Mutual Telephone Company	Not Awarded
Casey Mutual Telephone Co	\$2,648,200.05
Cedar Falls Utilities	\$2,338,336.60
Central Scott Telephone Company	\$4,280,286.19
Citizens Mutual Telephone Cooperative	\$1,610,874.73
Cloudburst9 LLC	Not Awarded
Colo Telephone	\$60,927.50
Comelec Services Inc. DBA Comelec Internet Services	Not Awarded
Coon Valley Cooperative Telephone Association Inc.	Not Awarded
Corn Belt Telephone Company, Inc.	Not Awarded
Cox Communications Omaha, LLC	Not Awarded
Cumberland Telephone Company	Not Awarded
Danville Mutual Telephone Company	\$1,670,925.00
Danville Mutual Telephone Company	\$3,549,250.00
Dunkerton Telephone Cooperative	Not Awarded
East Buchanan Telephone Cooperative	\$81,304.12
Evertex	Not Awarded
Farmers and Merchants Mutual Telephone Company	\$716,011.81
Farmers and Merchants Mutual Telephone Company	Not Awarded
FARMERS COOPERATIVE TELEPHONE	\$2,724,134.40
Farmers Mutual Cooperative Telephone Company	\$609,539.79
Farmers Mutual Cooperative Telephone Company	Not Awarded
Farmers Mutual Cooperative Telephone Company	\$50,601.00
FiberComm	Not Awarded
Grand Mound Cooperative Telephone Association	Not Awarded
Great Lakes Communication Corp	Not Awarded
Harmony Telephone Company	Not Awarded
Hawkeye Telephone Company	\$485,370.40
Hawkeye Telephone Company	\$619,365.54
Hawkeye Telephone Company	\$2,320,363.48
Hawkeye Telephone Company	\$1,127,300.38
Heart of Iowa Ventures, LLC	Not Awarded
IAMO Communications, Inc.	\$2,942,174.56

Kalona Cooperative Telephone Co	Not Awarded
Lehigh Valley Coop Telephone Association	\$251,501.00
Lockridge Networks	\$289,977.00
Mabel Cooperative Telephone Company	Not Awarded
Manning Municipal Utilities	\$2,195,220.67
Marne & Elk Horn Telephone Company	Not Awarded
Marne & Elk Horn Telephone Company	\$4,550,861.64
Mechanicsville Telephone Company	Not Awarded
Mechanicsville Telephone Company	\$78,397.41
Mediacom LLC	Not Awarded
Mediapolis Telephone Company	Not Awarded
Miles Communications LLC	Not Awarded
Minburn Telephone Company	\$793,410.60
Minburn Telephone Company	\$28,755.64
Minburn Telephone Company	\$23,625.10
Minerva Valley Telephone Co., Inc.	Not Awarded
Modern Cooperative Telephone Company	Not Awarded
Natel	Not Awarded
NEIT Services	Not Awarded
NEIT Services, LLC	\$2,167,004.19
Northwest Communications Cooperative Association	Not Awarded
Omnitel Communications, INC.	Not Awarded
Osage Municipal Utilities	Not Awarded
Palo Cooperative Telephone Association	Not Awarded
Panora Communications Cooperative	Not Awarded
Premier Communications, Inc.	\$7,405,174.31
Premier Communications, Inc.	\$1,745,433.90
Readlyn Telephone Company	Not Awarded
Reasnor Telephone Company, LLC	Not Awarded
River Valley Telecommunications Coop	Not Awarded
SAC COUNTY MUTUAL TELEPHONE	Not Awarded
Scranton Telephone Company	Not Awarded
Sharon Telephone Company	Not Awarded
South Slope Cooperative Telephone Company	\$1,037,881.73
South Slope Cooperative Telephone Company	Not Awarded
Spring Grove Communications	Not Awarded
Springville Cooperative Telephone Association	Not Awarded
Stratford Mutual Telephone	\$3,887,962.58
Sully Telephone Association, Inc.	Not Awarded
Templeton Telephone Company	Not Awarded
Terril Telephone Cooperative	Not Awarded
The Royal Telephone Company	Not Awarded
The Wyoming Mutual Telephone Company	Not Awarded

United States Cellular Corporation	Not Awarded
USA Communications	Not Awarded
Van Buren Telephone Company, Inc.	Not Awarded
Vinton Municipal Communications Utility (dba iVinton)	Not Awarded
Webster-Calhoun Cooperative Telephone Association	\$2,604,458.36
West Iowa Telephone Company	\$40,344.83
West Iowa Telephone Company	Not Awarded
Windstream Services, LLC	Not Awarded
WTC Communications, Inc.	Not Awarded
Total Grants Awarded	\$97,499,999.65

The below breaks out the applications and awards for the Central Iowa Broadband Internet Study Area:

Casey Mutual Telephone Company	\$2,648,200.05
Colo Telephone	\$60,927.50
Coon Valley Cooperative Telephone	0
Cumberland Telephone Company	0
Heart of Iowa	0
Mediacom	0
Minburn Communications	\$793,410.60
Minburn Communications	\$28,755.64
Minburn Communications	\$23,625.10
Minerva Valley	0
OmniTel	0
Panora Teleco Wireless	0
Reasnor	0
Stratford Mutual Telephone	\$3,887,962.58
Sully Telephone Company	0
US Cellular	0
Windstream	0
Total in Central Iowa	\$7,442,881.47
of Total Grants Awarded	7.60%

The number awarded in the 11-county study area of \$7,442,881.47 represents less than what would be expected. In examining how much would be expected at the highest level, the following formula applies



Total Awarded	# Iowa Counties	Expected \$ Per County	* 11 Counties	Actual in 11 Counties
\$97,499,999.65	99	\$984,848.48	\$10,833,333.29	\$7,442,881.47

Some of this discrepancy might be due to a more highly served urban and suburban population core, but it is clear more can be done in the future to enable a higher degree of competitiveness for available State dollars.

As other grants become available, these statistics point out some options to bring more grants to Central Iowa:

- Discussing with providers if the maximum number of grants were submitted
- Encouraging providers who did not receive grants to communicate with OCIO to see why their grants were not approved (OCIO has stated they will discuss the points a provider’s application was given)
- Work with providers to pursue the points they did not receive in this round

In addition to State of Iowa grants, other sources of broadband grants are:

**American Rescue Plan Act of 2021 (ARPA)**

The American Rescue Plan Act contained several provisions that made dollars available for improving access and adoption of improved broadband services. The key programs for purpose of this study are noted below.

**Capital Projects Grant**

The American Rescue Plan sets aside \$10 billion for capital projects that improve infrastructure for public services in the Capital Projects Grant. The amount of funding allocated to Iowa is \$152.2 million , as calculated based on the estimated number of unserved and underserved areas in the state.

It is not known yet how much the State will allocate to broadband, but this could fund the next round of broadband grants.

According to the Treasury, eligible projects must meet all of the following criteria:

- The capital project invests in capital assets designed to directly enable work, education, and health monitoring.
- The capital project is designed to address a critical need that resulted from or was made apparent or exacerbated by the COVID-19 public health emergency.
- The capital project is designed to address a critical need of the community to be served by it.

Explicitly outlined projects that meet these eligibility criteria include:

- Broadband Infrastructure Projects: The construction and deployment of broadband infrastructure designed to deliver service that reliably meets or exceeds symmetrical

speeds of 100 Mbps so communities have future-proof infrastructure to serve their long-term needs.

- Digital Connectivity Technology Projects: The purchase or installation of devices and equipment, such as laptops, tablets, desktop personal computers, and public Wi-Fi equipment, to facilitate broadband internet access for communities where affordability is a barrier to broadband adoption and use.
- Multi-Purpose Community Facility Projects: The construction or improvement of buildings designed to jointly and directly enable work, education, and health monitoring located in communities with critical need for the project.

Unserved and underserved households or businesses are those not currently or reliably served by a wireline connection of at least 25 Mbps down and 3 Mbps up. After completion of the project, the service must reliable (reliably means services that consistently meet the threshold of 25/3 Mbps) meet or exceed a symmetrical speed of 100/100 Mbps. In cases where that service requirement is not practicable, it must still meet 100 Mbps down, but can be between 20 Mbps and 100 Mbps up.

On June 17, 2021, the Treasury further clarified eligibility for an area is not limited to those that only have unserved or underserved households or businesses, but that sometimes those areas can also be included in the project if the larger area will facilitate economic feasibility and sustainability of the network. Similarly, ARPA funds can fund middle mile service as long as it is for the goal of supporting last mile customer service.

The timeline for these projects begins with states, territories, and tribal governments applying for the Fund within the following deadlines:

Type	Application Portal Launch Date	Deadline to Request Funding	Deadline to Submit Grant Plan
States, Territories & Freely Associated States	September 24, 2021	December 27, 2021	September 24, 2022

It further clarified that sources of data to identify eligible areas can be varied, not simply the FCC map, the new NTIA map, or state broadband maps, but also speed tests, interviews, and any other sources of information that can demonstrate the speeds and reliability of service witnessed in the community.

In addition, the Treasury categorically excluded DSL or DOCSIS 2.0 cable service from counting towards the speeds in an area. Even if those services provide the 25/3 Mbps service, both are a sufficiently aging, obsolete, and unreliable technology to warrant upgrades. For further information on the guidelines for states, see:

<https://home.treasury.gov/system/files/136/Capital-Projects-Fund-Guidance-States-Territories-and-Freely-Associated-States.pdf>

### **FCC Emergency Broadband Benefit**

The FCC has made available dollars to help people who are struggling to afford broadband connectivity. According to the FCC website (<https://www.fcc.gov/broadbandbenefit>)

The Emergency Broadband Benefit will provide a discount of up to \$50 per month towards broadband service for eligible households and up to \$75 per month for households on qualifying Tribal lands. Eligible households can also receive a one-time discount of up to \$100 to purchase a laptop, desktop computer, or tablet from participating providers if they contribute more than \$10 and less than \$50 toward the purchase price.

The City of West Des Moines developed a website to help people navigate utilization of this program. Jamie Letzring, Deputy City Manager, presented their work on this topic at the August 2021 Steering Committee meeting.

### ***Federal Infrastructure Dollars***

The federal government has been working on infrastructure funding. There have been different amounts of money that are planned to be dedicated to broadband. The broadband dollars appear to be proposed in the range of \$45 billion to \$60 billion. Negotiations on the Infrastructure Bill were continuing at the time of this report, but it appears likely the Federal government will approve the largest broadband funding project in the country's history.

It is also critical to note the outline of the program as drafted will push these dollars out of the FCC and into State hands in the form of block grants (similar to the Capital Fund). This means the State of Iowa is likely to be able to apply its more progressive definition of eligibility than has been the case with past FCC-governed grant programs, making more areas of Iowa eligible for funding.

# Economic Benefits of Broadband Improvement

## Executive Summary of Economic Benefits

This economic analysis estimates the direct economic benefits that would be realized if robust and ubiquitous broadband service was deployed in the study area which includes all of Adair, Dallas, Guthrie, Jasper, Madison, Marion, Marshall, Polk, Poweshiek, Story, and Warren counties in Iowa (collectively, the Center Iowa Study Area [CISA]).

The analysis shows unserved and underserved households in the CISA who adopt a robust broadband service can expect, on average, more than \$1,300 of increased income and savings annually. The analysis also shows adopting farms would see efficiency improvements that would boost average annual income by \$12,000.

Extending the household and farm gains to all unserved or underserved households in the study area over 20 years results in almost \$2 billion of benefit. Since investments are required to realize these benefits, the future benefit has been discounted by 4% annually to \$1.25 billion. The analysis follows a methodology used elsewhere in the Midwest that examines quantifiable benefits like income growth. There are other economic benefits which are difficult to quantify (e.g., improved educational outcomes) which could not be reliably calculated and thus not included in the benefit estimates.

Household adoption and the use of broadband internet is necessary to realize the calculated benefits. The analysis assumes a new service would be partially, not fully, adopted over a 10-year period by unserved and underserved households. On average, 19% more of the households in the CISA are assumed to adopt a new service by year 10 although there is some variation in counties based on the extent individual counties are already getting their needs met.

Increased benefits would be realized if broadband service was adopted by more households, or the adoption timeline was accelerated.

## Introduction of Economic Benefits of Improved Broadband

This analysis is one component of a larger Central Iowa Broadband Internet Study that The Partnership has coordinated on behalf of the CISA counties. The broadband infrastructure analysis identifies broadband gaps and needs in the CISA, estimates the infrastructure and investments needed to fill the gaps, and then proposes business and policy models to fill the gaps.

The analysis relies on an accepted methodology of calculating the incremental household income and savings which can be attributed to using the internet in day-to-day lives. The analysis is intended to be a conservative approximation of the benefits so officials and residents can make related decisions with confidence. This report discusses the major assumptions used in the economic calculations and shows how they were applied to the CISA.

Other elements of the overall Broadband Infrastructure Analysis informed and guided this economic analysis. The survey of over 4,000 residents and 200 businesses and focus groups of businesses, health providers, educators, and internet providers across the CISA were all highly informative in completing this economic analysis.

## Methodology to Determine Economic Benefits of Improved Broadband

This analysis leans on accepted methods of calculating economic benefit developed in studies by Grant and Tyner (2018) at Purdue University<sup>13</sup> and Spell and Low (2021) at the University of Missouri.<sup>14</sup> In both cases, the studies estimate the economic benefit households should realize if they went from having no or poor internet to having fast and reliable internet.

Several causal research papers underpin the assumptions for economic benefit inputs. The research yielded concrete benefits in the areas of household income, work from home, telemedicine, education, and farm income.

To realize the economic benefits of a new broadband service requires, of course, that households must use the new service. Adoption of a new service is inversely related to the existing market penetration. In other words, in an area where a high percentage of households already have broadband, there is little opportunity for new benefits to be realized. Conversely, areas with low existing broadband penetration would enjoy more overall economic benefits. The U.S. Census<sup>15</sup> provides data on households that don't have broadband and the soon to be published results from the Central Iowa Broadband Internet Study gave guidance on the portion of households that don't have satisfactory internet. Using this data, the analysis estimates the number of households that can reap economic benefits from new service.

---

<sup>13</sup> Grant, A., Tyner, W. (2018). Benefit-cost analysis for implementation of rural broadband in the Tipmont cooperative in Indiana. *Purdue Center for Regional Development*, <https://pcrd.purdue.edu/wp-content/uploads/2018/12/005-RPINsights-Tipmont-Broadband.pdf>

<sup>14</sup> Spell, A., Low, S. (2021). Economic benefits of expanding broadband in select Missouri counties. *University of Missouri Extension*, [https://extension.missouri.edu/media/wysiwyg/Extensiondata/Pro/ExCEED/Docs/BroadbandImpactReport\\_Jun2021.pdf](https://extension.missouri.edu/media/wysiwyg/Extensiondata/Pro/ExCEED/Docs/BroadbandImpactReport_Jun2021.pdf)

<sup>15</sup> U.S. Census Bureau American Community Survey 2019, Table S2801

## Adoption

Adoption of the new broadband service must occur to realize the economic benefits. The model assumes only portions of unserved households and underserved households will adopt the new service and thus realize the associated benefits.

### Unserved Household Adoption

The unserved households include those that do not currently have a home high-speed internet connection. U.S. Census data show less than 70% of the Central Iowa Study Area has fixed broadband such as cable, fiber optic, or DSL, meaning more than 30% are without broadband.<sup>16</sup> The unserved households also include Census respondents with slow or unreliable internet service, such as dial-up or satellite service.

The University of Missouri study assumes adoption increases of 10% to 20% for counties with less than 60% current penetration and 7.5% to 15% for counties with more than 60% current penetration. This CISA model assumes similar adoption levels but breaks the increases into additional groups to account for the significant variability in the counties throughout the CISA, as shown in Figure 15. The projected adoption of the new service goes as low as 5% to 10% for counties where existing broadband penetration is 70% or greater, or potentially as high as 20% in counties where existing broadband penetration is less than 50%.

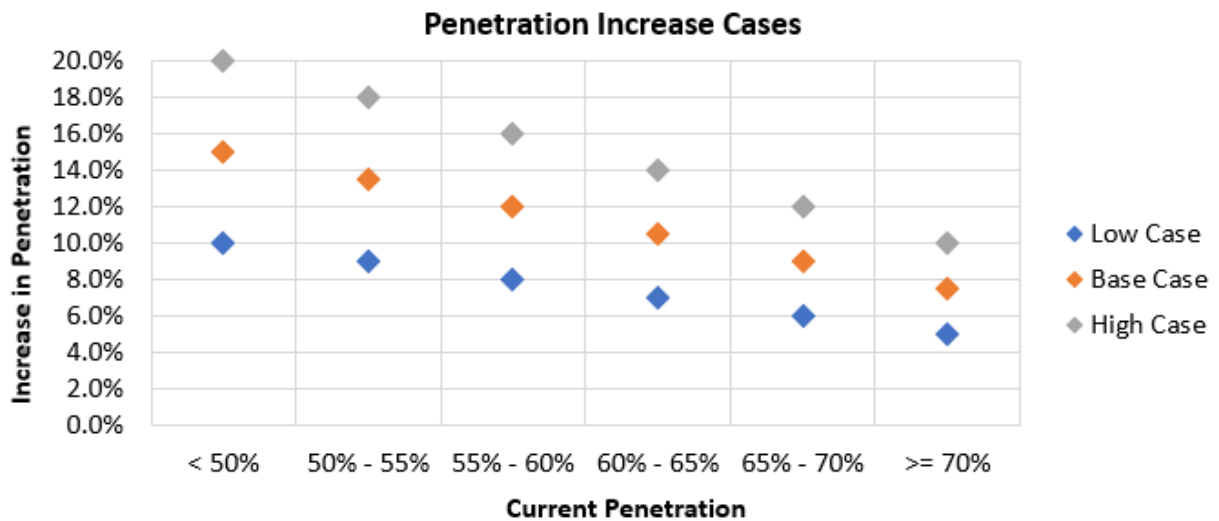

Figure 15 - New Broadband Adoption vs. Existing Broadband Penetration

<sup>16</sup> U.S. Census Bureau American Community Survey 2019, Table S2801

Given the sensitivity of penetration to the overall economic outcomes, the benefits are calculated for Low, Base, and High scenarios of final penetration as shown in Table 1.

Table 1 - Unserved Broadband Adoption by County

County	Current Penetration		Adoption			Pro Forma Penetration		
	%	Classification	Low	Base	High	Low	Base	High
Adair	41.8%	< 50%	10.0%	15.0%	20.0%	51.8%	56.8%	61.8%
Dallas	75.0%	>= 70%	5.0%	7.5%	10.0%	80.0%	82.5%	85.0%
Guthrie	47.3%	< 50%	10.0%	15.0%	20.0%	57.3%	62.3%	67.3%
Jasper	58.0%	55% - 60%	8.0%	12.0%	16.0%	66.0%	70.0%	74.0%
Madison	47.7%	< 50%	10.0%	15.0%	20.0%	57.7%	62.7%	67.7%
Marion	57.4%	55% - 60%	8.0%	12.0%	16.0%	65.4%	69.4%	73.4%
Marshall	58.1%	55% - 60%	8.0%	12.0%	16.0%	66.1%	70.1%	74.1%
Polk	71.2%	>= 70%	5.0%	7.5%	10.0%	76.2%	78.7%	81.2%
Powesh.	58.3%	55% - 60%	8.0%	12.0%	16.0%	66.3%	70.3%	74.3%
Story	68.6%	65% - 70%	6.0%	9.0%	12.0%	74.6%	77.6%	80.6%
Warren	61.4%	60% - 65%	7.0%	10.5%	14.0%	68.4%	71.9%	75.4%
<b>Total</b>	<b>67.7%</b>		<b>5.9%</b>	<b>8.8%</b>	<b>11.7%</b>	<b>73.6%</b>	<b>76.5%</b>	<b>79.5%</b>

## Underserved Household Adoption

The second group of adopters are the underserved households that: A) currently have internet service, B) their service is not of sufficient speed to realize the benefits of high-speed internet (e.g., video conferencing), and C) are likely to choose to adopt the new service because they are dissatisfied with their current service.

Analysis estimated the number of such underserved households by referencing the published Central Iowa Broadband Internet Study survey results. The survey included responses from more than 4,000 households from which the willingness to change services could be reasonably estimated. The survey criteria used to estimate the underserved households is:

- Currently subscribes to a home internet service,
- Download speed is below 25 Mbps,
- Respondent indicated a likelihood to recommend their existing internet service with a score of 3 or less (on a 1 to 10 scale), and
- Respondent indicated a likelihood to switch to reasonably priced, better-quality service with a score of 8 or higher (on a 1 to 10 scale)

The percentage of households that currently have home internet and meet the criteria above is 17.3% for the Central Iowa Study Area. While the percentages for the specific counties vary somewhat, there were no clear differences in adoption rates between rural and urban counties. As a result, the model assumes underserved households in all counties adopt at the same rate. Given the 17.3% includes households with dial-up and satellite service, we reduced the underserved rate to 15.0% to account for the fact that such households are already accounted for in the unserved population.

The model assumes service to both the unserved and underserved will be adopted linearly over the first five years. The ramped adoption accounts for the time to install service and the time for households to subscribe to the service once it is available. One or more years of planning

may be required prior to the first installation so this model becomes valid after completion of the first year of available service.

## Total Unserved and Underserved Adoption

Table 2 provides the assumed broadband adoption by county in the study area. The broadband adoption is assumed to occur evenly over the first 10 years of the model after which total adoption is assumed to be constant.

Table 2 - Broadband Adoptions by County

	[A]	[B]	= [A] * [B] [C]	[D]	= [C] + [D] [E]
County	Households with Current Service	New Service Adoption Rate	Underserved Adopting Households	Unserved Adopting Households	Total Adopting Households
Adair	41.8%	15.0%	6.3%	15.0%	21.3%
Dallas	75.0%	15.0%	11.2%	7.5%	18.7%
Guthrie	47.3%	15.0%	7.1%	15.0%	22.1%
Jasper	58.0%	15.0%	8.7%	12.0%	20.7%
Madison	47.7%	15.0%	7.2%	15.0%	22.2%
Marion	57.4%	15.0%	8.6%	12.0%	20.6%
Marshall	58.1%	15.0%	8.7%	12.0%	20.7%
Polk	71.2%	15.0%	10.7%	7.5%	18.2%
Poweshiek	58.3%	15.0%	8.8%	12.0%	20.8%
Story	68.6%	15.0%	10.3%	9.0%	19.3%
Warren	61.4%	15.0%	9.2%	10.5%	19.7%
Total	67.7%	15.0%	10.2%	8.8%	19.0%

The total addressable market, or the total number of households, is based on current levels per the Census,<sup>17</sup> and extrapolated for the next decade using the previous decade's growth rate as calculated from State of Iowa data.<sup>18</sup>

## Economic Benefits

The quantifiable economic benefits to the Central Iowa Study Area are presented below with the data used to arrive at these figures. There are other benefits to the CISA that are less tangible and thus difficult to quantify. These real, but less tangible economic benefits are discussed qualitatively later in this section.

The economic benefits are realized over time as service becomes available, households adopt the service, and usage behaviors evolve. Since a broadband investment today won't lead to economic gains until later, the economic benefits are discounted to a net present value (NPV).

## Total Study Area Benefits

The extended economic benefit to the CISA over 20 years is nearly \$2.0 billion in 2021 dollars with a net present value of \$1.25 billion as shown in Table 3 assuming Base Case level of adoption.

<sup>17</sup> U.S. Census Bureau American Community Survey 2019, Table S2801

<sup>18</sup> State of Iowa. Retrieved from <https://data.iowa.gov/Community-Demographics/County-Population-in-Iowa-by-Year/qtnr-zsrc/data>



Table 3 - 20-Year CISA Economic Benefits

<b>20-Year Economic Benefits For The Central Iowa Study Area</b>			
<i>\$ in millions</i>	<b>Low</b>	<b>Base</b>	<b>High</b>
Undiscounted	\$ 1,596	\$ 1,978	\$ 2,361
NPV @ 4.0%	\$ 1,008	\$ 1,251	\$ 1,495

The benefits are in real dollars and discounted at a 4.0% rate. Assuming 2.0% inflation, a 4.0% real rate is equivalent to a 6.0% nominal rate, which is a reasonable weighted average cost of capital for competitive market participants in the broadband space.

Research, discussed below, reveals where the primary economic benefits from reliable high-speed internet access applicable to the Central Iowa Study Area originate including household income, telehealth, working from home, education, and farm income. Table 4 below shows the total projected benefits for these categories over 20 years.

Table 4 - 20-Year Economic Benefits by Source

<b>20-Year Economic Benefits for the Central Iowa Study Area (Base Case)</b>			
<i>\$ in millions</i>	<b>Total</b>		<b>Single Year</b>
	<b>Undiscounted</b>	<b>NPV @ 4.0%</b>	<b>(Year 10 &amp; On)</b>
Household Income	973	598	65
Total Telehealth	452	293	26
Work From Home	73	48	4
Education	33	21	2
Farm Income	447	291	25
<b>Total</b>	<b>1,978</b>	<b>1,251</b>	<b>122</b>

The total economic benefits above are calculated from the gains realized by adopting households and extended this to the total number of adopting households in the CISA. To give perspective to the benefit calculations, it is useful to examine the benefits at the household level as shown in Table 5.

Table 5 - Annual Economic Benefits Per Household

<b>Annual Benefits per Household (Year 10 &amp; On)</b>		
<i>in \$ (per household)</i>	<b>Rural</b>	<b>Urban</b>
Household Income	\$ 884	\$ 884
Total Telehealth	372	335
Work From Home	56	56
Education	25	25
<b>Total - Non-Farm Households</b>	<b>\$ 1,338</b>	<b>\$ 1,301</b>
Farm Income	12,038	
<b>Total - Farm Households</b>	<b>\$ 13,375</b>	

Below, is an explanation of the benefit categories and how they were calculated shown in their order of overall economic impact to the CISA.

## Household Income

Household incomes tend to be higher in homes with broadband. These benefits are attributed to additional businesses in the region, adult distance learning, increased employment,

decreased unemployment, increased worker productivity, increased number of 'creative class' workers, or any number of other factors. Whitacre et al (2014) estimate, for non-metro counties, the increase in median household income is 1.3% over 10 years for counties with higher levels of penetration (=> 60%) compared to counties at moderate levels (40% to 60%).<sup>19</sup> Whitacre et al further found that counties with low levels of penetration (<40%), after controlling for other variables, had lower business and employment growth.<sup>20</sup>

The Whitacre et al. analysis is specific to non-metro counties that are near metropolitan areas, a group that is similar to all counties in the Central Iowa Study Area except for Polk, Dallas, and Story counties (which are classified as "metro counties"). However, we see no reason to expect benefits to household income wouldn't translate to the metro counties. While most studies focus on the impacts of broadband in rural areas, there are a couple of urban-rural agnostic studies that support the conclusion the benefits are universal. Ericsson (2013) finds that households in OECD countries (the vast majority of which are highly developed) gain around \$2,100 per year in income when going from having no broadband to broadband at 4 Mbps.<sup>21</sup> Furthermore, Hounghonon and Liang (2017) find in France that a 1% increase in broadband penetration increases mean income by 0.14%.<sup>22</sup> Therefore, we assume CISA metro households realize the same benefits as non-metro households.

Rather than assuming counties with substantial improvement in adoption see a full 1.3% increase in county-wide household income, as Whitacre et al. suggested, this analysis assumes median household income (MHHI) grows by 1.3% for only adopting households. With this approach, the highest increase in county-wide household income a county could realize in the base (adoption) case is 0.325% ( $1.3\% * 25\%$ ), since county-wide MHHI growth is proportional to the increase in adoption. For counties with smaller rates of adoption, such as Polk and Dallas counties, the increase in county-wide MHHI is 0.228% ( $1.3\% * 17.5\%$ ).

The 1.3% income growth is phased-in linearly over 10 years, based on the 10-year period analyzed in Whitacre et al.,<sup>23</sup> to allow for behavioral changes to take hold. For example, the additional household income gain is 0.13% in Year 1, 0.65% in Year 5, and 1.3% in Year 10 and beyond.

The weighted average annual median household income across the Central Iowa Study Area in Year 10, weighted by the number of new adopting households, was calculated at \$67,989 using U.S. Census Bureau data.<sup>24</sup> With a 1.3% gain, the resulting benefit in Year 10 is \$884 per new household with broadband service.

---

<sup>19</sup> Whitacre, B., Gallardo, R., & Strover, S. (2014). Broadband's contribution to economic growth in rural areas: Moving towards a causal relationship. *Telecommunications Policy*, 38(11), 1011-1023.

<sup>20</sup> Whitacre et al., 2014.

<sup>21</sup> Ericsson. (2013). *Measuring the impact of broadband on income: A study on the socioeconomic effects of broadband speed on household income*. <https://www.ericsson.com/498440/assets/local/about-ericsson/sustainability-and-corporate-responsibility/documents/download/impact-of-broadband-speed-on-household-income.pdf>

<sup>22</sup> Hounghonon, G., Liang, J. (2017). Broadband internet and income inequality. *HAL Archives-Ouvertes*. <https://hal.archives-ouvertes.fr/hal-01653815/document>

<sup>23</sup> Whitacre et al., 2014.

<sup>24</sup> U.S. Census Bureau American Community Survey 2019, Table S1901

While this analysis focuses on the increase in median income for existing households and additional households that rise naturally from organic population growth, we note that increased availability of broadband can create inorganic population growth by causing migration into areas with broadband service. New households could be attracted by the ability to work from home, by the creation of new jobs in the area, or any number of the other economic and standard of living benefits of broadband service. Such population gains could feed broader economic benefits not measured in this approach.

## **Telemedicine**

Telemedicine represents the second largest area of economic benefit to Central Iowa Study Area households with a calculated benefit of over \$450 million during the 20-year study period. The telemedicine benefits are discussed below:

### **Patient Savings From Reduced Use of Emergency Departments**

Patients with broadband access to telemedicine are assumed to have fewer emergency room (ER) visits per year. Nord et al. aggregated various sources to show the average ER visit costs \$943, while a telehealth consultation is only \$45.<sup>25</sup> The average savings is \$898. Gordon et al. estimate the savings at \$1,735.<sup>26</sup> This analysis conservatively uses \$898 of savings.

A Center for Disease (CDC) 2018 survey indicates that Americans visit the ER at a rate of 40.4 visits per 100 people per year.<sup>27</sup> With Census data showing an average Central Iowa Study Area household size of 2.5 individuals<sup>28</sup>, this roughly equates to one visit per household per year. This analysis assumes that adopting households substitute 10% of their ER visits with telehealth consultations, resulting in average savings of \$89 per household per year.

### **Patient Savings From Initial Health Consultation via the Internet**

Similar to ER savings, patients with access to telemedicine are assumed to make fewer in-person medical visits. Nord et al. show that savings can be realized by substituting a telehealth consultation for visiting a doctor's office (\$54), retail health clinic (\$36), or urgent care facility (\$80).<sup>29</sup> In contrast, Gordon et al. estimate higher savings of \$162, \$36, and \$153 respectively.<sup>30</sup> This analysis conservatively used Nord et al.'s projected savings. Assuming one person in each household makes an in-person medical visit of each type annually (3.0 visits total), savings would total \$170 per year for each adopting household.

### **Patient Transportation Savings Due to Avoided In-Person Medical Visits**

---

<sup>25</sup> Nord, G., Rising, K., Band, R., Carr, B., Hollander, J. (2019). On-demand synchronous audio video telemedicine visits are cost effective. *The American Journal of Emergency Medicine*, 37(5), 890-894.

<sup>26</sup> Gordon, A., Adamson, W., DeVries, A. (2017). Virtual visits for acute, nonurgent care: a claims analysis of episode level utilization. *Journal of Medical Internet Research*, 19(2):e35.  
<https://doi.org/10.2196/jmir.6783>

<sup>27</sup> Cairns, C., Kang, K., Santo, L. (2018) National Hospital Ambulatory Medical Care Survey: 2018 emergency department summary tables. [https://www.cdc.gov/nchs/data/nhamcs/web\\_tables/2018-ed-web-tables-508.pdf](https://www.cdc.gov/nchs/data/nhamcs/web_tables/2018-ed-web-tables-508.pdf)

<sup>28</sup> U.S. Census Bureau American Community Survey 2019, Table S1101

<sup>29</sup> Nord et al., 2019.

<sup>30</sup> Gordon et al., 2017.

The reduction of in-person medical visits discussed above will eliminate the expense of traveling to and from the nearest facility for treatment. This analysis uses the typical distance from the nearest hospital as a proxy for the distance traveled. According to a Pew Research Center survey, the average urbanite lives 4.4 miles from the nearest hospital, while the average household in a rural area has an average of 10.5 miles to travel.<sup>31</sup>

This analysis defines urban households as those residing in a metropolitan area, which is Ames and Des Moines and surrounding suburbs. Using the 2021 Internal Revenue Service (IRS) mileage rate of \$0.56 per mile, and incorporating the 3 trips year assumed above, a rural household would save \$35 annually. New urban Adopting Households would save \$15.

### **Recovered time savings due to avoided in-person medical visits**

Recovered time due to avoided travel and waiting times provides an additional quantifiable benefit. Given most medical appointments occur during business hours, recovered time is most likely to be allocated to work. It's assumed two out of every three in-person medical visits involve a working adult patient or chaperone, resulting in two visits per household per year where savings are generated. The Pew survey indicates average roundtrip time to the nearest hospital by car is 0.17 hours for urban households and 0.28 hours for rural households.<sup>32</sup> An additional half-hour is added for excess waiting and appointment time attributable to in-person visits. The resulting savings is \$61 for urban households and \$77 per year for rural households.

### **Work From Home**

Working from home provides numerous benefits. Among them is eliminating the need to commute. Before the COVID-19 pandemic, in August 2019, the percentage of workers in the U.S. that telecommuted in some capacity was 42%, and such workers telecommuted 5.8 days out of 20 per month as reported by Gallup.<sup>33</sup> During the pandemic, in August 2020, the percentage of telecommuters increased to 49%, and the average work from home days then doubled to 11.9 days per month.<sup>34</sup> While many workers that need or want to work from home have likely already sought out a home with a strong internet connection, it is expected that increased broadband penetration and businesses' new views towards remote work will afford additional work from home opportunities. Research documenting this relationship has not yet been published since many consider society in a transition period. Nonetheless, this analysis reasonably assumes 10% of new households adopting broadband will have one worker begin working from home at the pre-pandemic average of 5.8 days per month. Given the recent business and worker appetite for remote work, this again appears to be a conservative assumption.

---

<sup>31</sup> Lam, O., Broderick, B., Toor, S. (2018, December 12). *How far Americans live from the closest hospital differs by community type*. Pew Research Center. <https://www.pewresearch.org/fact-tank/2018/12/12/how-far-americans-live-from-the-closest-hospital-differs-by-community-type/>

<sup>32</sup> Lam et al., 2018.

<sup>33</sup> Jones, J. (2020, August 31). *U.S. remote workdays have doubled during pandemic*. Gallup. <https://news.gallup.com/poll/318173/remote-workdays-doubled-during-pandemic.aspx>

<sup>34</sup> Jones, 2020.

The average round trip commute time for Iowans is 38.6 minutes per the Census.<sup>35</sup> Assuming an average speed of 40 miles per hour, the round-trip distance is 14.5 miles. At the \$0.56 per mile 2021 IRS rate, the average annual benefit per new household with broadband service is \$56.

We do not include any additional benefits of working from home and assume that other benefits, such as increased efficiency, flexibility, or earning power, are captured in the Household Income section.

## Education

We estimated Kindergarten to 12th grade (K-12) teacher productivity gains using research from Smith et al.<sup>36</sup> This research included a teacher survey where 20% of respondents indicated that online resources saved them up to one hour a week, while an additional 20% indicated they saved up to two hours a week. This time savings works out to an average of 0.6 hours saved a week due to online resources. The time savings are multiplied by estimated total teacher salaries for each county. The productivity gain will help reduce educator burn-out and reduce overall educational cost particularly during the prolonged shortage of educators.

Due to the overlap of school districts between counties, total teacher salaries are calculated via a normalized estimate. First, the estimated average teacher salary cost per enrolled student for each county is calculated using data from the Iowa Department of Education.<sup>37</sup> This is then multiplied by an assumed number of students for each county, which is the product of the number of adopting households and the state of Iowa average enrolled students per household.<sup>38</sup> As a result, the benefits are proportional to the percentage of households that are adopting households. The average annual savings for the Central Iowa Study Area is calculated to be \$25 per household that adopts broadband service.

## Farm Income

Precision agriculture is widely accepted to provide significant benefits to crop and livestock production including improvements in quality and quantities, reductions in environmental impact, and improvements in cost efficiencies. The importance of precision agriculture to the nation's food security, environment, and economy has led to the creation of a FCC Task Force on Precision Agriculture Technology Needs. The Task Force's sub-committee Examining Current and Future Connectivity Demand for precision agriculture has issued an interim report qualitatively showing the benefits of precision agriculture if adequate connectivity existed. Below are some select farm benefits applicable to the Central Iowa Study Area resulting from precision agriculture and improved broadband:

---

<sup>35</sup> U.S. Census Bureau American Community Survey 2019. Retrieved from <https://www.census.gov/search-results.html?q=Average+Commute+Time+Census&page=1&stateGeo=none&searchtype=web&cssp=SERP>

<sup>36</sup> Smith, P., Rudd, P. and Coghlan, M. (2008), *Harnessing Technology Schools Survey 2008: Report 1 . Coventry: Becta*. Retrieved at: [https://dera.ioe.ac.uk/1549/1/becta\\_2008\\_htssanalysis\\_report.pdf](https://dera.ioe.ac.uk/1549/1/becta_2008_htssanalysis_report.pdf)

<sup>37</sup> Iowa Department of Education. (2020, April 14). *2019-2020 Iowa public school full time teachers*. Educate Iowa. <https://educateiowa.gov/documents/iowa-public-school-and-aea-teacher-counts-and-salaries-district/2021/05/2019-2020-iowa-0>

<sup>38</sup> Iowa Department of Education and Census

#### Row Crops:

- Remote monitoring for soil preparation, seed singulation, grain quality, in-season fertilization, irrigation, disease, pest and weed control.
- Yield mapping
- Auto-steer equipment
- Inventory monitoring (e.g. moisture, CO<sub>2</sub>)
- Next season planning based on previous season production

#### Livestock

- Health and wellbeing monitoring at the animal level
- Production monitoring at the animal level (e.g. dairy)
- Automated feed delivery

The sub-committee report expects the precision agriculture technologies, and hence the benefits, to continue to improve over time.

A few studies quantitatively estimate gains in crop farming from expanded broadband access. LoPicallo (2020) finds that doubling the number of 25 Mbps download and 3 Mbps upload speed (25+/3+) connections in an area is associated with a 3.6% increase in corn yields and 3.8% increase in soybean yields.<sup>39</sup> LoPicallo also finds doubling the number of 10+ Mbps (up) /1+ Mbps connections (down) is associated with a 2.4% decrease in operating expenses for farm operations. Kandilov et al. find estimates indicate that receipt of a USDA broadband loan is positively associated with high-speed internet use among farmers and that increased access to high-speed internet leads to about a 6% increase in farm revenue and 3% increase in farm profits, primarily due to crop production gains.<sup>40</sup> According to the USDA, "if broadband internet infrastructure, digital technologies at scale, and on-farm capabilities were available at a level that met estimated producer demand, the U.S. could realize economic benefits equivalent to nearly 18% of total production."<sup>41</sup>

Like any business of scale, farms with quality internet would also enjoy business efficiencies. Just a few types of activities a farm operation would use the internet for are:

- Meteorological information: past, current, and forecasted
- Fleet management
- Just-in-time inventory management
- Digital contracts
- Access to market prices and inventory
- Sales, trades, and shipments confirmations

Agricultural sales data, used in the analysis, was obtained from the 2017 USDA Census of Agriculture. The agricultural sales for the Central Iowa Study Area totaled \$2.13 billion. In our base case, the weighted average broadband adoption rate of households that did not

---

<sup>39</sup> LoPicallo, K. (2020). Impact on Broadband Penetration on U.S. Farm Productivity. *Office of Economics and Analytics*, Federal Communications Commission working paper.

<https://docs.fcc.gov/public/attachments/DOC-368773A1.pdf>

<sup>40</sup> Kandilov, A., Kandilov, I., Xiangping, L., and Renkow, M. (2011). The impact of broadband on US agriculture: an evaluation of the USDA broadband loan program. *Applied Economic Perspectives and Policy*. 39(4): 635-661.

<sup>41</sup> United States Department of Agriculture. (2019). *A case for rural broadband*.

<https://www.usda.gov/sites/default/files/documents/case-for-rural-broadband.pdf>

previously have broadband across the Central Iowa Study Area, weighted by county agricultural sales, is 11.6% in Year 5. Adopting households in the underserved group are not included. Assuming a gain in farm income that is 0.1% of sales for every 1.0% increase in adoption, similar to the approach by Spell and Low,<sup>42</sup> the farm income benefit is 0.116% or \$24.8 million per year. We do not calculate a benefit amount in dollars per household as these benefits will only accrue to farm businesses.

## Less Tangible Economic Benefits

The generally accepted and quantifiable economic benefits of broadband in the CISA are presented above. There are, however, other economic advantages that are difficult to quantify but exist nonetheless. When considering the economic realities of broadband, the following should be also be kept in mind.

**Aging In Place / Home Care:** Iowa's population over 75 is projected to grow as a percentage of the overall population through 2040 according to the Iowa Data Center.<sup>43</sup> Access to many of the essential services, medications, food, and other products are becoming increasingly convenient to research and order on the internet and increasingly inconvenient to arrange through other means. The internet can also help reduce social isolation. For those who are homebound or wish to age in place, there are potential cost savings compared to commercial or institutional settings and the benefits provided by the internet can only be expected to grow.

**Civic Engagement:** The well-being of a community is often tied to the engagement of its residents in activities such as volunteerism, organization membership, involvement in local causes, religious affiliation, school activities, and campaigning. Voting turnout is considered a proxy for such civic engagement. Recent research from the 2016 and 2018 elections concluded there was a positive linkage between internet use and voter turnout. Interestingly, the study also concluded that smartphone use did not change the likelihood of voter turnout.<sup>44</sup>

**Consumer Savings:** A study conducted in the United Kingdom by Price Waterhouse Coopers estimates consumers save £560 (\$754) per year in insurance, energy, general shopping, and for services online.<sup>45</sup> However, a high-speed fixed broadband connection is not necessary to realize these benefits. Slower internet service or mobile broadband should provide sufficient connections. Per Census data, more than 80% of households in the Central Iowa Study Area already have a fixed or mobile broadband connection.<sup>46</sup> Therefore, it is assumed the vast majority of households willing to shop online consistently are already doing so. In addition, while local retail firms increased their sales by actively using social media to market to local

---

<sup>42</sup> Spell et al., 2021.

<sup>43</sup> Iowa Data Center (2020). Older Iowans 2020.  
<https://www.iowadatacenter.org/Publications/older2020.pdf>

<sup>44</sup> Robinson, A. et al., 2021. *Is a Digital Nation a Voting Nation?* National Telecommunications and Information Administration. [https://papers.ssrn.com/sol3/papers.cfm?abstract\\_id=3760187](https://papers.ssrn.com/sol3/papers.cfm?abstract_id=3760187)

<sup>45</sup> UK Government. (2014, December 4). *Government digital inclusion strategy*. Available from: <https://www.gov.uk/government/publications/government-digital-inclusion-strategy/government-digital-inclusion-strategy#contents>

<sup>46</sup> U.S. Census Bureau American Community Survey 2019, Table [S2801]

households,<sup>47</sup> online shopping, on the whole, may lead to lower sales for local retailers as households with broadband shift their purchases to external sellers, as has been seen with Amazon.

**Educational Outcomes:** The economic benefits previously calculated take credit for the efficiencies which benefit K12 educators. Student and educator access to the internet affords additional learning environments, training of digital skills, additional opportunities for disabled students, and generally improved outcomes. Improved education leads to higher educational attainment, which is well documented to lead to higher incomes, on average, across a population.

**Home Values:** Molnar et al. estimate that high-speed broadband access (greater than 25 Mbps) leads to a 3.1% increase in housing values.<sup>48</sup> Whitacre and Deller found evidence of a national broadband premium, but the premium was very small for the existence of speeds over 10 to 25 Mbps,<sup>49</sup> while Conley and Whitacre found no evidence of broadband premium in rural Oklahoma after adjusting home sales price data for individual home characteristics.<sup>50</sup> We chose not to include this as a benefit as the increase in home values is likely due to homeowners' willingness to pay more for a home in which they can realize the economic benefits of high-speed internet, hence the additional home value is primarily a reflection of other economic benefits. In addition, homeowners would have to sell their home to realize the value and would likely be selling to another family from the same area, creating no net benefit within the study area. We note that higher home values would lead to higher property tax payments, but the benefit would be immaterial, given the increase in property taxes is small and the higher payments are primarily a value transfer rather than an overall gain to the Central Iowa Study Area.

**Home Internet Becomes an Imperative:** Due to employment, education, medical, and quality of life benefits, having internet has become a requirement, not an option, for some individuals. The economic benefits quantified above afford these options to a portion of the population for the first time. However, the opposite can also occur as the internet becomes an increasingly essential element of society. In these cases, the lack of internet will lead to outbound migration causing localized labor shortages.

## **GDP Growth – Comparative Benefit Calculation**

The core approach of this analysis, as shown above, is to measure the direct, quantifiable benefits to households. An alternative approach is to measure the total increase in economic activity through metrics such as GDP, employment, or overall labor income. Spell and Low (2021) use this method to show the overall economic impact of broadband on three illustrative

---

<sup>47</sup> Aldashev, A., Batkeyev, B. (2021). Broadband infrastructure and economic growth in rural areas. *Information Economics and Policy*. <https://doi.org/10.1016/j.infoecopol.2021.100936>

<sup>48</sup> Molnar, Gabor & Savage, Scott & Sicker, Douglas. (2019). High-speed Internet access and housing values. *Applied Economics*. 51(55), 1-14. <https://doi.org/10.1080/00036846.2019.1631443>

<sup>49</sup> Whitacre, B., Deller, S. (2019, July 17). Research report: Broadband availability raises market value of rural houses. *The Daily Yonder*. <https://dailyyonder.com/broadbands-value-rural-houses/2019/07/17/>

<sup>50</sup> Whitacre, B., Conley, K. (2020). Home is where the internet is? High-speed internet's impact on rural housing values. *International Regional Science Review*, 43(5). <https://journals.sagepub.com/doi/10.1177/0160017620918652>



counties in Missouri, two of which have existing penetration levels that are comparable to the Central Iowa Study Area counties in this study.<sup>51</sup> Henry County, in west central Missouri, has 48.0% broadband penetration. Nodaway County, which borders Iowa in northwest Missouri, has 65.4% penetration. The Missouri analysis assumes minimum and maximum adoption increases that are roughly comparable to the CISA model’s low and high cases.

Spell and Low use an economic input-output model to understand the total benefits derived from broadband adoption. The model uses direct inputs, similar to the household benefits assumed in this report, and incorporates indirect purchases, such as new in-county spending spurred by the direct inputs. Their model considers typical spending patterns, such as what types of goods or services are purchased locally, to follow the flow of income that stays within a county and hence spurs economic gains. Even in the minimum case, the benefits are substantial.

We believe the gains estimated for these counties should be illustrative of the benefits achievable for non-metro counties (i.e., all counties except Polk and Dallas) in the Central Iowa Study Area. These relative gains are shown in the following table.

Table 6 - Estimated 10-Year GDP Increase in CISA

	<b>Henry County, MO</b>		<b>Nodaway County, MO</b>		<b>Central Iowa Study Area</b>		
Current Penetration	48.0%		65.4%		67.7%		
<b>Case</b>	<b>Min</b>	<b>Max</b>	<b>Min</b>	<b>Max</b>	<b>Low</b>	<b>Base</b>	<b>High</b>
Penetration Increase	10.0%	20.0%	7.5%	15.0%	5.9%	8.8%	11.7%
New Penetration Level	58.0%	68.0%	72.9%	80.4%	73.6%	76.5%	79.5%
<b>10-Year Average Annual Benefit <sup>(1)</sup></b>							
Employment Increase	1.5%	2.9%	0.8%	1.5%			
Labor Income Increase	1.9%	3.5%	0.9%	1.7%			
GDP Increase	1.7%	3.2%	0.8%	1.4%			

<sup>(1)</sup> As a percent of 2019 levels

In other words, the non-metro CISA counties could expect average GDP gains over 10 years ranging from 0.8% to 3.2%. We expect gains would be lower for the metro counties, but still meaningful.

Applying the anticipated GDP gains discussed above to all counties in the study area results in real dollar gains as shown Table 7 assuming a 0.5% increase in GDP from the adoption of reliable high-speed internet.

<sup>51</sup> Spell et al., 2021.

Table 7 - Estimated GDP Increase by County in Year 10

*\$ in millions*

<b>County</b>	<b>2019 GDP</b>	<b>0.5% Increase</b>
Adair	\$ 409	\$ 2.0
Dallas	4,499	22.5
Guthrie	469	2.3
Jasper	1,100	5.5
Madison	376	1.9
Marion	1,788	8.9
Marshall	1,788	8.9
Polk	38,100	190.5
Powesh.	1,073	5.4
Story	4,900	24.5
Warren	1,080	5.4
<b>Total</b>	<b>\$55,584</b>	<b>\$ 277.9</b>

This alternative approach yields substantially higher benefits than the direct household benefits approach presented above. For example, a 0.5% GDP increase translates to \$278 million of annual benefit to the CISA, whereas the annual direct benefit to households calculated above at Year 10, is \$122 million. The difference is primarily due to the scope of the benefits. The GDP benefits incorporate all economic activity, while the direct household benefits are limited to certain categories for which the gains are clear, quantifiable, and likely to accrue to the average household in the CISA.

It should be noted that GDP gains would accrue in part to businesses, some of whom may distribute the benefits to external stakeholders, thereby decreasing the total value of benefits retained in the CISA. While the GDP gains forecasted are genuine, they may not be suitable for calculating the net benefit to the CISA. This alternative (GDP) approach, however, provides valuable insight to the size of broadband's impact on economic activity and provides a validating point of comparison for the net benefits calculated via the direct household approach.

## Exhibits

Exhibit 1 - Total Benefit by Year Since Service Introduction

*\$ in thousands*

<b>Year</b>	<b>Total Telemedicine</b>	<b>K-12 Education</b>	<b>Household Income</b>	<b>Work From Home</b>	<b>Farm Income</b>	<b>Total Benefit</b>
1	\$ 4,537	\$ 333	\$ 1,141	\$ 737	\$ 4,962	\$ 11,710
2	9,196	675	4,631	1,494	9,924	25,920
3	13,980	1,025	10,573	2,271	14,887	42,736
4	18,896	1,386	19,074	3,069	19,849	62,273
5	23,946	1,756	30,247	3,888	24,811	84,647
6	24,280	1,780	36,841	3,941	24,811	91,653
7	24,621	1,804	43,633	3,995	24,811	98,865
8	24,971	1,829	50,630	4,051	24,811	106,292
9	25,328	1,855	57,838	4,108	24,811	113,940
10	25,694	1,881	65,267	4,166	24,811	121,819
11	25,694	1,881	65,267	4,166	24,811	121,819
12	25,694	1,881	65,267	4,166	24,811	121,819
13	25,694	1,881	65,267	4,166	24,811	121,819
14	25,694	1,881	65,267	4,166	24,811	121,819
15	25,694	1,881	65,267	4,166	24,811	121,819
16	25,694	1,881	65,267	4,166	24,811	121,819
17	25,694	1,881	65,267	4,166	24,811	121,819
18	25,694	1,881	65,267	4,166	24,811	121,819
19	25,694	1,881	65,267	4,166	24,811	121,819
20	25,694	1,881	65,267	4,166	24,811	121,819
<b>Total</b>	<b>\$ 452,382</b>	<b>\$ 33,136</b>	<b>\$ 972,545</b>	<b>\$ 73,380</b>	<b>\$ 446,600</b>	<b>\$ 1,978,044</b>
<b>NPV</b>	<b>\$ 293,209</b>	<b>\$ 21,480</b>	<b>\$ 597,567</b>	<b>\$ 47,566</b>	<b>\$ 291,277</b>	<b>\$ 1,251,099</b>

Exhibit 2 - Telemedicine Benefits

\$ in thousands

Year	Primary Visit	Retail Visit	Urgent Visit	Emergency	Transport	Missed Work	Total
1	\$ 706	\$ 470	\$ 1,045	\$ 1,166	\$ 288	\$ 862	\$ 4,537
2	1,430	953	2,118	2,362	583	1,748	9,196
3	2,174	1,449	3,220	3,591	886	2,660	13,980
4	2,937	1,958	4,351	4,852	1,198	3,600	18,896
5	3,721	2,481	5,513	6,147	1,518	4,566	23,946
6	3,772	2,515	5,588	6,231	1,538	4,635	24,280
7	3,824	2,549	5,665	6,317	1,560	4,705	24,621
8	3,877	2,585	5,744	6,405	1,581	4,777	24,971
9	3,932	2,621	5,825	6,495	1,603	4,851	25,328
10	3,988	2,658	5,907	6,587	1,626	4,927	25,694
11	3,988	2,658	5,907	6,587	1,626	4,927	25,694
12	3,988	2,658	5,907	6,587	1,626	4,927	25,694
13	3,988	2,658	5,907	6,587	1,626	4,927	25,694
14	3,988	2,658	5,907	6,587	1,626	4,927	25,694
15	3,988	2,658	5,907	6,587	1,626	4,927	25,694
16	3,988	2,658	5,907	6,587	1,626	4,927	25,694
17	3,988	2,658	5,907	6,587	1,626	4,927	25,694
18	3,988	2,658	5,907	6,587	1,626	4,927	25,694
19	3,988	2,658	5,907	6,587	1,626	4,927	25,694
20	3,988	2,658	5,907	6,587	1,626	4,927	25,694
Total	\$ 70,236	\$ 46,824	\$ 104,053	\$ 116,028	\$ 28,644	\$ 86,598	\$ 452,382
<b>NPV</b>	<b>\$ 45,528</b>	<b>\$ 30,352</b>	<b>\$ 67,449</b>	<b>\$ 75,212</b>	<b>\$ 18,568</b>	<b>\$ 56,101</b>	<b>\$ 293,209</b>

Exhibit 3 - Benefits by County

NPV @ 4.0%

\$ in millions	Year 5	Year 10	Year 10	Total	K-12	Household	Work From	Farm	Total
	Benefit	Benefit	Households	Telemed	Education	Income	Home	Income	Benefit
Adair	\$ 3.3	\$ 3.6	663	\$ 2.7	\$ 0.2	\$ 4.3	\$ 0.4	\$ 33.1	\$ 40.8
Dallas	9.6	16.7	9,338	37.5	2.4	95.7	5.7	20.9	162.2
Guthrie	4.2	4.6	975	4.1	0.3	7.2	0.6	40.0	52.3
Jasper	5.6	6.8	3,100	13.0	0.9	22.1	2.0	35.6	73.7
Madison	3.1	3.8	1,511	6.5	0.4	12.1	1.0	21.0	40.9
Marion	3.7	4.8	2,804	11.8	0.8	20.7	1.8	15.6	50.7
Marshall	5.8	7.0	3,193	13.5	1.0	21.8	2.1	37.5	75.9
Polk	31.8	50.7	38,339	148.7	11.6	309.4	24.7	9.8	504.2
Poweshiek	5.0	5.6	1,612	6.5	0.5	10.5	1.1	44.3	62.9
Story	8.0	11.3	8,046	30.5	2.3	54.6	5.2	23.8	116.4
Warren	4.6	7.0	4,263	18.2	1.1	39.2	2.8	9.7	71.0
Total	\$ 84.6	\$ 121.8	73,843	\$ 293.2	\$ 21.5	\$ 597.6	\$ 47.6	\$ 291.3	\$ 1,251.1

# Broadband and Post-Pandemic Normal

## Broadband and Post-Pandemic Normal Executive Summary

The COVID-19 pandemic has accelerated digital trends that were already on the horizon as society turned to the internet to meet their daily needs. As new behaviors become more permanent, our broadened dependency on regional digital infrastructure will continue to increase. It is incontrovertible broadband is now an essential utility, as vital as reliable electricity and clean water.

The pandemic caused consumer and business uses of the internet to evolve and scale almost overnight. Attending school, working from home, visiting a doctor, and accessing government services all suddenly depended upon reliable broadband connections. Services such as Zoom, Google Classroom, and Netflix became deeply embedded in the everyday life of many people. It is now typical that households may have multiple high-bandwidth services running concurrently. The need for speed has shifted from being a luxury to a requirement.

Broadband's applications are so far-reaching that these physical networks affect a range of social and economic outcomes. From educational success, access to health care, economic productivity, greater agricultural output, enhanced civic participation, and social support, broadband delivers numerous benefits that affect the quality of life for families and communities.

As it stands, Iowa ranks 45th in the nation in broadband access and has the second-slowest internet speed nationwide, with an average download speed of 78.9 Mbps according to BroadbandNow.<sup>52</sup>

The pandemic has exposed the seriousness and extent of the digital divide (i.e., the gap between those who have access to high-speed internet and suitable devices and those who do not).

Those caught on the wrong side of this divide are disconnected from economic, educational, health, entertainment and social opportunities. As there is little sign that all these aspects of society will move away from their emerging digital channels, those without access to affordable and reliable broadband, as well as the technology to take advantage of it, will be left farther behind in the coming years.

For the benefit of our residents, communities and economy, the time has come to bridge the digital divide and bring affordable, reliable, high-speed broadband to every Iowan.

---

<sup>52</sup> BroadbandNow. (2021, February 2). *Internet access in Iowa*. <https://broadbandnow.com/iowa>

# Current and Future Broadband Needs and Trends

## Introduction

During the COVID-19 pandemic, the fixed and mobile networks that enable our digital lives have proved critical. Attending school, working from home, visiting a doctor, and accessing government services have all relied on steady broadband connections. The home internet connection truly became a gateway to the world around us. According to a survey conducted in April 2020, nearly nine out of ten Americans (87%) said the internet had been important or essential to them during the outbreak.<sup>53</sup> Although the world is reopening, we should not assume that internet usage will go back to pre-pandemic levels of normal. It is important to take a look at how consumer behaviors have changed and will continue to evolve into the future to better assess and plan for what is ahead.

### Broadband 101

**Broadband:** The Federal Communications Commission (FCC) sets a standard for broadband as internet service with a download speed of at least 25 megabits-per-second (Mbps) and an upload speed of at least 3 Mbps.

**Upload and Download:** The direction of the data between the end user and the service provider. Something moving “upstream” or “uploading” is moving from the end user’s computer or device to the service provider, while data moving “downstream” or “downloading” is moving from the service provider to the end user. Downstream is important in applications like streaming video, while upstream is important for end users who need to send large files somewhere, for instance, to a customer or to a hospital.

**Symmetric and Asymmetric:** Whether the up and down speeds match. A rate of 10 Mbps down/10 Mbps up would be symmetric, while a speed of 10/1 would be asymmetric.

**Bandwidth:** The amount of data that can be transferred per second. Bandwidth determines how fast data can be transferred over time.

**Latency:** How long it takes data to travel between its source and destination, measured in milliseconds. Latency is delay.

---

<sup>53</sup> Vogels, E. A., Perrin, A., Rainie, L., & Anderson, M. (2020, April 30). *53% of Americans say the internet has been essential during the COVID-19 outbreak*. Pew Research Center. <https://www.pewresearch.org/internet/2020/04/30/53-of-americans-say-the-internet-has-been-essential-during-the-covid-19-outbreak/>

## Telework

The COVID-19 pandemic has produced a massive shift to working from home, ushering in a new era of how a large segment of the workforce may operate in the future. Advances in technologies such as cloud computing, videoconferencing, and online collaboration tools have enabled remote working in many jobs where in-person interactions were expected, particularly for knowledge workers. According to the U.S.-based consulting firm McKinsey & Company, 20-25% of the workforce in advanced economies could work from home between three to five days a week as effectively as they could if working from an office. If remote work and hybrid arrangements take hold at this level, this would represent a shift of four to five times as many people working from home compared to the time before the pandemic.<sup>54</sup>

There are many indications that the widespread adoption of work from home policies is not just a short-term solution tied to the pandemic. Numerous large businesses, including Mondelez, Barclays, and Nationwide have indicated they plan to implement permanent hybrid work models. Nationwide, for instance, announced that on-site work will be limited to its four main corporate offices in Ohio, Iowa, Arizona, and San Antonio, with employees in other locations shifting to working from home.<sup>55</sup> A survey by McKinsey found that on average, executives planned to reduce office space by 30%.<sup>56</sup> In a working paper based on data drawn from 15,000 Americans, researchers at the University of Chicago forecast that 22% of all full work days in the U.S. will be supplied from home after the pandemic ends, compared with just 5% before.<sup>57</sup>

This shift to more remote work will result in much greater demand for residential broadband, not only in service speeds, but also in types of service. In the absence of remote work, most homes are adequately served with asynchronous connections that provide much greater download than upload speeds, as residential internet activity focused primarily on the consumption of data (streaming movies, browsing the internet, downloading files, shopping, etc.). Working from home, however, requires greater upload speeds and often synchronous connections to accommodate a productivity model wherein users complete video calls or upload and sync large files with their employer's computer systems. While remote work is not possible across all industries or job functions, where it is possible, expansive broadband will be vital to maintaining a stable and engaged workforce.

---

<sup>54</sup> Lund, S., Madgavkar, A., Manyika, J., Smit, S., Ellingurd, K., Meaney, M., & Robinson, O. (2021, February 18). *The future of work after Covid-19*. McKinsey & Company. <https://www.mckinsey.com/featured-insights/future-of-work/the-future-of-work-after-covid-19>

<sup>55</sup> Akala, A. (2020, May 1). *More big employers are talking about permanent work-from-home positions*. CNBC. <https://www.cnbc.com/2020/05/01/major-companies-talking-about-permanent-work-from-home-positions.html>

<sup>56</sup> Lund et al., 2021

<sup>57</sup> Barrero, J. M., Bloom, N., & Davis, S. J. (2020, December). *Why working from home will stick* (Working Paper No. 2020-174). Becker Friedman Institute for Economics. [https://bfi.uchicago.edu/wp-content/uploads/2020/12/BFI\\_WP\\_2020174.pdf](https://bfi.uchicago.edu/wp-content/uploads/2020/12/BFI_WP_2020174.pdf)

## Online Learning

When the pandemic struck in March 2020, school closures impacted 55 million school children and 14 million college students in the United States.<sup>58</sup> In an attempt to continue instruction, students, families, and school professionals had to adapt rapidly to distance learning. Schools employed technologies like Google Classroom and Zoom, which became essential tools for many teachers and professors to manage virtual learning. Once COVID-19 is brought under control, practices adopted on the fly may become lasting changes to the way schools do business. In fact, according to a recent RAND survey, 20% of K-12 school districts and charter management organizations said that they have already adopted, were planning to adopt, or were considering adopting a virtual school or fully remote option after the end of the pandemic. Another 10 % said the same about hybrid or blended learning, while 7% said some lesser version of remote learning will continue when the pandemic is in the rearview mirror. District leaders mentioned wanting to offer students more flexibility, meeting parent or student demand, meeting the diversity of students' needs, and maintaining enrollment as reasons for remote instruction outlasting the COVID-19 pandemic.<sup>59</sup>

Higher education, too, will be changed by the mass migration to virtual learning even after the COVID-19 crisis passes. To understand the impacts of the new higher education model spurred by COVID-19, the Economist Intelligence Unit (EIU) conducted surveys and interviews with faculty and students in the US, the UK, Australia, and Germany. Its findings indicate that rather than being a short-term solution, remote and hybrid learning are likely to be a future operating model for many higher education institutions alongside on-campus programs. Faculty members across the board (85%) are convinced that the crisis has accelerated the future of the virtual education revolution by a decade. Alongside a striking 72% of faculty members predicting that all courses will shift to online-only in the long-term, more than 81% anticipate the creation of hybrid learning models.<sup>60</sup>

Internet service must meet certain download and upload speeds to be effective in a distance learning environment. With videoconferencing increasingly used for distance learning, coupled with other household video needs, such as working from home and telemedicine, household download and upload speed requirements are increasing. Recent analysis by Common Sense Media recommends in order to engage in robust distance learning *today*, students need access to speeds of 200/10 Mbps. This speed allows for a level of connectivity that ensures students are less likely to be interrupted due to problems related to connectivity and also allows schools to choose among a wider range of education technologies and develop a more robust

---

<sup>58</sup> Sallet, J. (2020, November 20). *What 2020 taught us about broadband*. Benton Institute for Broadband & Society. <https://www.benton.org/blog/what-2020-taught-us-about-broadband>

<sup>59</sup> Schwartz, H., Grant, D., Diliberti, M. K., Hunter, G. P., & Setodji, C. M. (2020). *Remote learning is here to stay*. Rand Corporation. [https://www.rand.org/pubs/research\\_reports/RRA956-1.html](https://www.rand.org/pubs/research_reports/RRA956-1.html)

<sup>60</sup> Economist Intelligence Unit. (2020). *Bridging the digital divide to engage students in higher education*. The Economist. <https://eddownloads.azureedge.net/msdownloads/EIU-Microsoft-Education-Bridging-the-Digital-Divide-2020.pdf>



curriculum.<sup>61</sup> In order to ensure universal access to high-quality distance learning in the future, however, Common Sense Media recommends broadband infrastructure capable of 100/100 Mbps.<sup>62</sup>

## Telehealth

Telehealth – the use of telecommunications technologies to deliver health-related services and information that support patient care, administrative activities, and health education - was slow to grow before the COVID-19 pandemic hit, largely stifled by complex State and Federal regulations. Changes in regulations at the outset of the pandemic, however, have allowed the practice to become much more common as patients attempted to avoid busy, potentially dangerous medical facilities, and as Congress appropriated emergency stimulus funds to support telehealth.

Between mid-March and the summer of 2020, more than 9 million Medicare beneficiaries used telemedicine, a more than 5,000% increase from the prior three months.<sup>63</sup>

Once the pandemic is over, experts predict telemedicine will similarly play a much larger role than before. According to McKinsey, 46% of health care consumers in the U.S. are now using telehealth, which is up from 11% in 2019, and 76% are interested in using telehealth more in the future.<sup>64</sup> In addition, 57% of providers now view telehealth more favorably than they did before the pandemic and 64% are more comfortable using it.<sup>65</sup> Global Market Insights estimates that global telehealth will be a \$176 billion industry by 2026. This 19.2% compound annual growth rate (CAGR) will be largely fueled by worldwide telecommunication network developments, market opportunities in rural areas or those without easy access to health care services, and the continuing integration of health care and IT market sectors.<sup>66</sup>

---

<sup>61</sup> Chandra, S., Chang, A., Day, L., Liu, J., McBride, L., Mudalige, T., & Weiss, D. (2020). *Closing the K-12 Digital Divide in the Age of Distance Learning*. Common Sense Media.

[https://www.common sense media.org/sites/default/files/uploads/pdfs/common\\_sense\\_media\\_report\\_final\\_7\\_1\\_3pm\\_web.pdf](https://www.common sense media.org/sites/default/files/uploads/pdfs/common_sense_media_report_final_7_1_3pm_web.pdf)

<sup>62</sup> Chandra, S., Fazlullah, A., Hill, H., Lynch, J., McBride, L., Weiss, D., & Wu, M. (2020). *Connect all students: How states and school districts can close the digital divide*. Common Sense Media.

[https://d2e111jq13me73.cloudfront.net/sites/default/files/uploads/common\\_sense\\_media\\_partner\\_report\\_final.pdf](https://d2e111jq13me73.cloudfront.net/sites/default/files/uploads/common_sense_media_partner_report_final.pdf)

<sup>63</sup> Fowler, G. A. (2020, December 28). In 2020, we reached peak Internet. Here's what worked — and what flopped. *The Washington Post*. <https://www.washingtonpost.com/topics/road-to-recovery/2020/12/28/covid-19-tech/>

<sup>64</sup> Bestsennyy, O., Gilbert, G., Harris, A., & Rose, J. (2020, May 29). *Telehealth: A quarter-trillion-dollar post-COVID-19 reality?* McKinsey & Company. <https://www.mckinsey.com/industries/healthcare-systems-and-services/our-insights/telehealth-a-quarter-trillion-dollar-post-covid-19-reality>

<sup>65</sup> Bestsennyy, et al., 2020)

<sup>66</sup> Ugalmugle, S., & Swain, R. (2020, April 13). *Global telemedicine market size to surpass \$175 Bn by 2026*. Global Market Insights. <https://www.gminsights.com/pressrelease/telemedicine-market>

With physician shortages increasing and the population aging, the utilization of telehealth services may be more important than ever. Harnessing the potential of telehealth requires having a reliable and fast internet connection that can accommodate the use of secure videoconferencing, transmission of high-definition images, and remote patient monitoring. According to the telehealth firm eVisit, ideally, patient internet speeds should be at least 15 Mbps download and 5 Mbps upload in order to have a clear video experience.<sup>67</sup> A successful transition to telemedicine not only requires access to adequate broadband but access to technology and sufficient digital skills as well.

## Telehealth Applications

According to the American Telehealth Association, the most commonly used telehealth applications include:

- Virtual visits (traditional phone calls and videoconferencing platform sessions between a doctor and a patient);
- Chat-based interactions (back-and-forth, non-live communication and sharing of information over email, text messaging or online portals);
- Remote patient monitoring (the use of wearable sensors and other devices to collect and transmit information regarding the patient's condition back to health care providers); and
- Technology-enabled modalities (digital diagnostics and therapeutics, consultation between physicians, and general data transmission and interpretation).<sup>68</sup>

## Digital Government

The COVID-19 crisis has brought new needs for digital government services and more demand for existing services. When the pandemic hit, governments took immediate steps to improve their user experience and employee productivity by updating their websites, digitizing paper-based forms, harnessing cloud solutions, and streaming public meetings. These shifts are not just temporary solutions. After the public health emergency subsides, government business processes, practices, and investments will continue to center around making IT operations work more efficiently for workers and citizens. According to a recent survey by the National Association of State Chief Information Officers (NASCIO), the top three policy and technology priorities for State CIOs in 2021 are 1) cybersecurity and risk management, 2) digital government/digital services, and 3) cloud services.<sup>69</sup> While the pandemic has accelerated the availability of online citizen services, both data connectivity and digital literacy will be crucial to make them useful, secure, and robust.

---

<sup>67</sup> Iafolla, T. (2016, May 12). *What are the basic technical requirements for telehealth?* eVisit. <https://blog.evisit.com/virtual-care-blog/what-are-the-basic-technical-requirements-for-telehealth>

<sup>68</sup> American Telehealth Association. (2020). *Telehealth: Defining 21<sup>st</sup> century care.* <https://www.americantelemed.org/resource/why-telemedicine/>

<sup>69</sup> National Association of State Chief Information Officers. (2020). *State CIO top 10 priorities.* [https://www.nascio.org/wp-content/uploads/2020/12/NASCIO\\_CIOTopTenPriorities.pdf](https://www.nascio.org/wp-content/uploads/2020/12/NASCIO_CIOTopTenPriorities.pdf)

## E-Commerce

When the COVID-19 pandemic hit, the shift from bricks-and-mortar to digital shopping had been underway for some time. Digital Commerce 360 estimates the pandemic accelerated this shift by two years.<sup>70</sup> Faced with stay-at-home orders and store closures, millions of Americans resorted to shopping online and home delivery services. Data from the U.S. Census Bureau shows e-commerce sales amounted to \$792 billion in 2020, which is equivalent to 14% of total retail sales. That is up from just 7.3% in 2015, illustrating the pace at which sales have moved online over the past few years and particularly in 2020.<sup>71</sup>

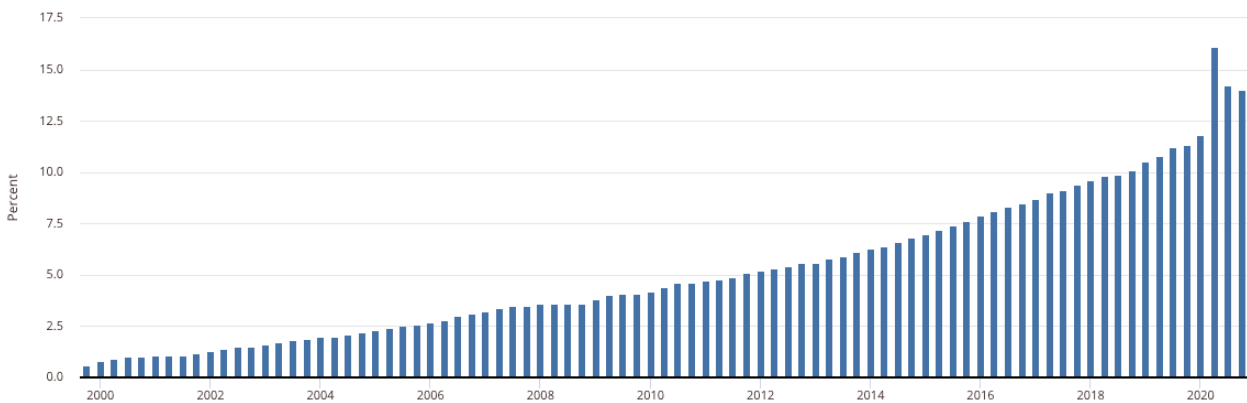

Figure 16 - E-Commerce Retail Sales as a Percent of Total Sales<sup>72</sup>

The crisis has expanded the scope of e-commerce, bringing in new firms, consumer segments (e.g., elderly) and products (e.g., groceries). Meanwhile, e-commerce transactions have partly shifted from luxury goods and services towards everyday necessities, relevant to a large number of individuals.<sup>73</sup> The shift toward online channels is likely to continue post-pandemic given the convenience of the new purchasing habits, learning costs, and the incentive for firms to capitalize on investments in new sales channels.

On the consumer side, many new digital behaviors are also expected to stick. According to McKinsey, retail categories with higher online penetration before the pandemic saw a dramatic increase in percent spent online during the April 2020 shelter-in-place rules, growing from 37% penetration before COVID-19 to over 80% at its highest. While penetration went down during

<sup>70</sup> Digital Commerce 360. (2021, March 22). *Data dive: How COVID-19 impacted ecommerce in 2020*.

<https://www.digitalcommerce360.com/article/coronavirus-impact-online-retail/>

<sup>71</sup> U.S. Census Bureau. (2021, February 19). *Quarterly retail e-commerce sales 4th quarter 2020*.

[https://www.census.gov/retail/mrts/www/data/pdf/ec\\_current.pdf?](https://www.census.gov/retail/mrts/www/data/pdf/ec_current.pdf?)

<sup>72</sup> U.S. Census Bureau. (2021, February 19). *E-Commerce retail sales as a percent of total sales*. Federal Reserve Bank of St. Louis.

<https://fred.stlouisfed.org/series/ECOMPCTSA>

<sup>73</sup> Organisation for Economic Co-operation and Development (OECD). (2020, October 7). *E-commerce in the time of COVID-19*. <https://www.oecd.org/coronavirus/policy-responses/e-commerce-in-the-time-of-covid-19-3a2b78e8/>

the second half of 2020, it has remained at a higher level than before the pandemic, with online penetration in January 2021 at 48%.<sup>74</sup>

On the supply side, many operators of brick-and-mortar stores are now considering e-commerce a crucial complimentary or alternative sales channel. Since the move to online sales requires an investment, many of the firms that have enhanced their participation in e-commerce during the pandemic have an incentive to capitalize on their acquired infrastructure or skills over the long run.<sup>75</sup> As e-commerce continues to build momentum, access to broadband networks is essential for businesses of any size to be able to effectively interact with customers and stay competitive.

## Play and Entertainment

The COVID-19 pandemic has changed consumer entertainment behaviors, solidifying the foothold of digital streaming services, such as Netflix and Hulu. In the U.S. alone, the number of streaming subscriptions rose by 32% in 2020, to a total of 308.6 million.<sup>76</sup> In addition, consumers who subscribe to a paid streaming services now hold an average of five subscriptions, up from three just before the pandemic.<sup>77</sup>

With consumers streaming entertainment from their devices, premium video on demand (PVoD)—in which new movies are released directly to streaming video services and can be watched for an additional fee—has emerged as a viable way for studios to reach movie fans. In the first few months of the pandemic, Deloitte found 22% of consumers had paid to rent or watch a PVoD movie, and 90% of those said they would do so again. By October 2020, a second Deloitte survey showed 35% of consumers had watched a PVoD release.<sup>78</sup> The dramatic shifts in consumer media consumption habits over the past year are thought to be long-lasting.

According to a recent survey by Brightback, nearly 86% of online video subscribers say they anticipate keeping or increasing their number of subscriptions in 2021.<sup>79</sup> For those who stream video from online sources, the speed at which data can be sent to their home is critical. For instance, Netflix recommends minimum internet download speeds of 3 Mbps for streaming in

---

<sup>74</sup> Charm, T., Gillis, H., Grimmelt, A., Hua, G., Robinson, K., & Sanchez Caballero, R. (2021, March 24). *Survey: US consumer sentiment during the coronavirus crisis*. McKinsey & Company. <https://www.mckinsey.com/business-functions/marketing-and-sales/our-insights/survey-us-consumer-sentiment-during-the-coronavirus-crisis>

<sup>75</sup> OECD, 2020.

<sup>76</sup> MarketWatch. (2021, March 18). *Global streaming subscriptions top 1B during COVID*. <https://www.marketwatch.com/story/global-streaming-subscriptions-top-1b-during-covid-2021-03-18>

<sup>77</sup> Arkenberg, C., Ledger, D., Loucks, J., & Westcott, K. (2021, January 19). *How streaming video services can tackle subscriber churn*. Deloitte. <https://www2.deloitte.com/us/en/insights/industry/technology/video-streaming-services-churn-rate.html>

<sup>78</sup> Arkenberg, C., Cutbill, D., Loucks, J., & Westcott, K. (2020, December 10). *The future of movies*. Deloitte. <https://www2.deloitte.com/us/en/insights/industry/technology/future-of-the-movie-industry.html>

<sup>79</sup> Brightback. (2021). *2021 state of industry report: Retaining and expanding online subscribers post-pandemic*. [https://cdn.brightback.com/assets/Brightback\\_StateofIndustry\\_2021.pdf?mtime=20210215100540&focal=none](https://cdn.brightback.com/assets/Brightback_StateofIndustry_2021.pdf?mtime=20210215100540&focal=none)

standard definition (SD), 5 Mbps for high definition (HD), and 25 Mbps for 4K/Ultra HD (UHD). With 4K UHD TVs becoming the norm, bandwidth requirements will increase.

The COVID-19 pandemic has also been an energizer for the gaming industry. Quarantine policies fueled existing trends and massively increased the popularity of the already fast-growing industry. A recent study by Simon-Kucher & Partners estimates that post-pandemic, there will be a permanent 21% increase in monthly spending by gamers and a permanent 11% increase in time spent gaming.<sup>80</sup> The study also discovered a shift in what types of games are being played and how gaming content is being consumed. Gamers are playing more multiplayer games, specifically game types with social components, and streaming more video game content.<sup>81</sup>

Twitch, the live-streaming site where people watch other people play video games in live webcasts and chat with others in real time, clocked 17 billion hours of viewed content in 2020, a full 83% higher than 2019's 9 billion hours.<sup>82</sup> When it comes to speed requirements for online gaming, the Federal Communications Commission recommends a minimum download speed of 3 Mbps for a regular gaming console and 4 Mbps for multiplayer games. While internet speeds are important, having a high-quality, low-latency internet connection is critical as online video games must reflect the action in real time on the player's display. Any lag between the action and its display on the screen will compromise the gameplay and gaming experience.

## Future Considerations

In sum, the COVID-19 pandemic has revealed just how essential high-performance and high-quality broadband is to participate in today's society. Work, learning, health care, government services, and other facets of everyday life will be more dependent on broadband in the future than in the immediate past. Today's households need reliable fixed broadband connections with robust downstream and upstream speeds and low latency supporting multiple simultaneous users.

Broadband providers report many customers have opted for faster connections with greater capacities since the onset of the COVID-19 pandemic. Data from OpenVault show in Q4 2020, for the first time, over half (50.6%) of subscribers are now provisioned for the 100 to 200 Mbps speed tier. The overall percentage of subscribers provisioned for gigabit speed is 8.5%, an increase of 301% from the same time a year ago and lower speed tiers of less than 100 Mbps are now seeing penetration of only 21.5%.<sup>83</sup> Speed has been increasingly important for

---

<sup>80</sup> Jaeger, L., Zarb, N., & David, A. (2020, August 26). *Global gaming study: More gamers spending more money in COVID lockdowns – which publishers will benefit?* Simon-Kucher & Partners. <https://www.simon-kucher.com/en-us/blog/new-global-gaming-industry-study-gamers-spend-more-money-and-time-increase-social-contact>

<sup>81</sup> Jaeger et al., 2020

<sup>82</sup> Stephen, B. (2021, January 11). *Twitch ended 2020 with its biggest numbers ever*. The Verge. <https://www.theverge.com/2021/1/11/22220528/twitch-2020-aoc-among-us-facebook-youtube>

<sup>83</sup> OpenVault. (2021). *Broadband insights report (OVBI): 4Q2020*. [https://openvault.com/wp-content/uploads/new/OpenVault\\_OVBI\\_Q420.pdf](https://openvault.com/wp-content/uploads/new/OpenVault_OVBI_Q420.pdf)

Americans as they have become more reliant on the internet for everyday activities and use more bandwidth-intensive applications over an increasing number of devices. The table below, from the FCC’s Household Broadband Guide, compares minimum download speed needed for some common applications and how running multiple applications simultaneously affects speed requirements. As more applications are deployed and the number of devices proliferate, broadband connections will need to accommodate the increased bandwidth load.

Table 8: FCC Household Broadband Guide<sup>84</sup>

	Light Use	Moderate Use	High Use
	(Basic functions: email, browsing, basic video, VoIP, Internet radio)	(Basic functions plus one high-demand application: streaming HD video, multiparty video conferencing, online gaming, telecommuting)	(Basic functions plus more than one high-demand application running at the same time)
<b>1 user on 1 device</b>	3-8 Mbps	3-8 Mbps	12-25 Mbps
<b>2 users or devices at a time</b>	3-8 Mbps	12-25 Mbps	12-25+ Mbps
<b>3 users or devices at a time</b>	12-25 Mbps	12-25 Mbps	25+ Mbps
<b>4 users or devices at a time</b>	12-25 Mbps	25+ Mbps	25+ Mbps

One of the issues to consider when looking forward is broadband speeds are a moving target – that is, the need for residential and business broadband grows every year. In the United States, Cisco estimates the average fixed broadband speed will grow 2.4-fold from 2018 to 2023, from 58.9 Mbps in 2018 to 143.6 Mbps in 2023.<sup>85</sup> According to the Fiber Broadband Association (FBA), residential demand for both upstream and downstream bandwidth has been growing at a rate of 20 to 25% annually for over two decades. The FBA projects peak demand for a family of four should exceed 400 Mbps symmetric in roughly seven years, with bandwidth needs accelerating in the years after that.<sup>86</sup>

<sup>84</sup> Federal Communications Commission. (2020, February 5). *Household broadband guide*. <https://www.fcc.gov/consumers/guides/household-broadband-guide>

<sup>85</sup> Cisco. (2020). *Cisco annual internet report highlights tool*. <https://www.cisco.com/c/en/us/solutions/executive-perspectives/annual-internet-report/air-highlights.html#>

<sup>86</sup> Bloomfield, S., & Bolton, G. (2020, December 18). Ex Parte Filing by NTCA–The Rural Broadband Association and the Fiber Broadband Association in WC Docket No. 20-269 – Inquiry Concerning Deployment of Advanced Telecommunications Capability to All Americans in a Reasonable and Timely Fashion [Letter to Federal Communications Commission]. <https://www.ntca.org/sites/default/files/federal-filing/2020-12/NTCA-FBA%20Section%20706%20Ex%20Parte.pdf>.

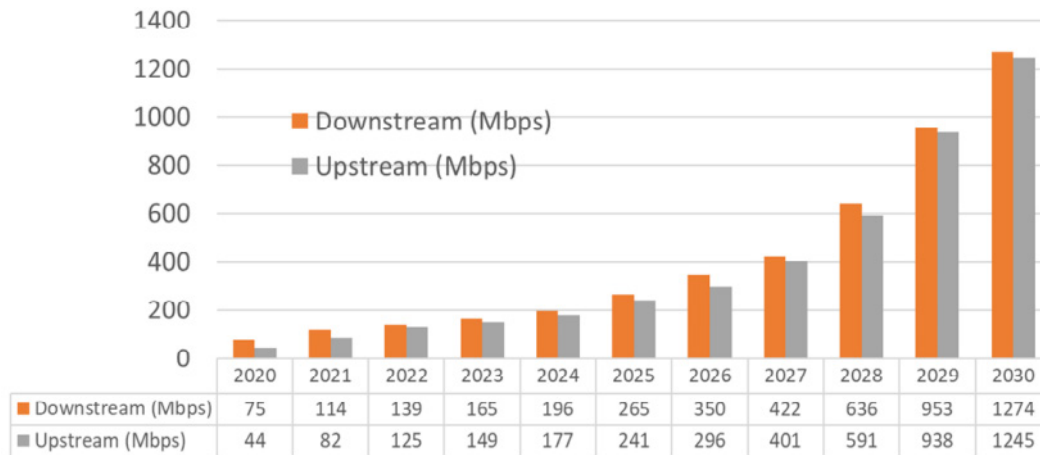

Figure 17 - FBA Project Peak Bandwidth Requirements – Household of 4<sup>87</sup>

Future increases in the need for substantially greater downstream and upstream bandwidth are being driven by an array of new technologies, including 8K video, virtual reality (VR), and augmented reality (“AR”). These technologies hold substantial promise for consumers and businesses, such as greatly improved virtual education, telemedicine, work from home, business, security, and entertainment. Planning ahead, networks should be built that are both useful now and, in the future, when Americans will rely upon them to an even greater extent for so many aspects of everyday life. Figures 3 and 4 on the following pages show estimates of needs for both businesses and residences projected five and 10 years into the future.

<sup>87</sup> Fiber Broadband Association. (2020). Comments Before the Federal Communications Commission. In the Matter of Inquiry Concerning Deployment of Advanced Telecommunications Capability to All Americans in a Reasonable and Timely Fashion. <https://starterkit.fiberbroadband.org/d/do/3835>

	<b>LARGE BUSINESS</b>		<b>SMALL BUSINESS</b>		<b>HOME BASED WORKER</b>		<b>BUSINESS FROM HOME</b>	
<b>DESCRIPTION</b>	A larger business with about 50 workstations.		A small business with 10 to 15 employees, and 7-10 workstations.		A single employee working at home for his/her company.		A home business with one or two employees working at home.	
	Concurrent Use	Mbps	Concurrent Use	Mbps	Concurrent Use	Mbps	Concurrent Use	Mbps
Telephone	20	1.28	5	0.32	1	0.064	1	0.064
TV		0		0		0		0
HDTV		0		0		0		0
Credit Card Validation	4	4	1	1		0		0
Security System	1	0.25	1	0.25	1	0.25	1	0.25
Internet	20	30	7	10.5	1	1.5	1	1.5
VPN Connection	5	25		0	1	5		0
Data Backup	5	7.5	1	1.5	1	1.5	1	1.5
Web Hosting	1	2		0		0		0
Workforce Training (online classes)	2	20	1	10	0	0	1	10
HD Video-conferencing	10	100	2	20	1	10	1	10
Telecommuting	5	15	2	6	0	0	0	0
<b>Totals</b>		<b>205.0</b>		<b>49.6</b>		<b>18.3</b>		<b>23.3</b>
<b>5 YEARS FROM NOW (MBPS)</b>	<b>615</b>		<b>149</b>		<b>55</b>		<b>70</b>	
<b>10 YEARS FROM NOW (MBPS)</b>	<b>1845</b>		<b>446</b>		<b>165</b>		<b>210</b>	

Figure 18 - Business Bandwidth Needs<sup>88</sup>

<sup>88</sup> Design Nine Broadband Planners. (n.d.). Broadband Assessment and Plan for Clinton, Lycoming, Northumberland, and Union Counties: A SEDA-COG Initiative. [https://seda-cog.org/wp-content/uploads/SEDA-COG\\_broadband\\_report-reduced.pdf](https://seda-cog.org/wp-content/uploads/SEDA-COG_broadband_report-reduced.pdf)



	RESIDENTIAL DAYTIME		EARLY EVENING		EVENING & LATE NIGHT		SNOW DAY	
<b>DESCRIPTION</b>	Intermittent Television and Internet use across a small percentage of households.		Increased Internet use as children arrive home from school and employees from work.		Peak television and Internet use. Multiple TV's are on, phone and computer being used.		On top of typical daytime traffic children are home from school, and many employees are home working.	
	Concurrent Use	Mbps	Concurrent Use	Mbps	Concurrent Use	Mbps	Concurrent Use	Mbps
Telephone	1	0.064	1	0.064	1	0.064	1	0.064
Standard Definition TV	1	2.5	1	2.5	1	2.5	1	2.5
HD TV	1	4	2	8	2	8	3	12
Security System	1	0.25	1	0.25	1	0.25	1	0.25
Internet	1	1.5	1	1.5	2	3	3	4.5
Online Gaming		0.25		0.5		1		1
VPN Connection	0	0	1	2	1	2	2	4
Data Backup		0	1	5	1	5	1	0
Telehealth (subscriber)	1	4	1	4	1	4	0	0
Distance Learning		0	1	10	1	10	2	20
HD Video-conferencing		0		0		0	1	14
<b>Totals</b>		<b>12.6</b>		<b>33.8</b>		<b>35.8</b>		<b>58.3</b>
<b>Five years from now (MBPS)</b>	<b>38</b>		<b>101</b>		<b>107</b>		<b>175</b>	
<b>Ten years from now (MBPS)</b>	<b>113</b>		<b>304</b>		<b>322</b>		<b>525</b>	

Figure 19 - Residential Bandwidth Needs<sup>89</sup>

<sup>89</sup> Design Nine Broadband Planners. (n.d.).

# Impacts of Broadband Availability on Overall Quality of Life

## Introduction

Broadband access, or the lack thereof, has far-reaching effects. It has a direct impact on educational performance, health care access, and economic outcomes to name a few. The Federal Communications Commission (FCC) estimates that 21.3 million Americans lack access to broadband internet defined as having 25 Mbps download and 3 Mbps upload speeds. Other estimates are higher. BroadbandNow estimates that number to be closer to 42 million.<sup>90</sup> In Iowa, more than 387,000 residents lack access to 25/3 Mbps broadband.<sup>91</sup> The significance of the access gap was thrust into the spotlight in 2020 when the COVID-19 pandemic forced Iowans to transition to working, learning, and performing other daily activities from home.

The sharp digital divides that exist in our communities vary among geographic areas and demographic groups. When it comes to broadband *availability*, the FCC's 2020 Broadband Deployment Report shows that approximately 84% of residents in rural areas of Iowa have broadband access, compared to approximately 98% of those living in Iowa's urban areas.<sup>92</sup> However, it should be noted that research from BroadbandNow argues these numbers are over reported, and the number of Iowans who have the ability to purchase broadband internet is actually lower in both urban and rural areas.<sup>93</sup>

A gap also exists among different groups when it comes to broadband *adoption*. According to a 2021 Pew Research survey, Americans with lower levels of income and education, minorities, and senior citizens, are more likely to be non-adopters compared to their counterparts. Over 9 in 10 households that make over \$75,000 a year have adopted home broadband, compared with only 57% of households that make under \$30,000 a year. Only 46% of US adults whose

### Digital Divide

The term "digital divide" refers to the gap between individuals, households, businesses and geographic areas at different socioeconomic levels with regard to both their opportunities to access information and communication technologies (ICTs) and to their use of the internet for a wide variety of activities.

### Availability Vs Adoption

Broadband availability refers to whether or not broadband service is offered. Broadband adoption refers to the extent to which households actually subscribe to and use fixed broadband.

---

<sup>90</sup> Busby, J., Tanberk, J. & BroadbandNow Team. (2021, March 25). *FCC reports broadband unavailable to 21.3 million Americans, BroadbandNow study indicates 42 million do not have access*. BroadbandNow. <https://broadbandnow.com/research/fcc-underestimates-unserved-by-50-percent>

<sup>91</sup> Busby, J., Tanberk, J. & Cooper, T. (2021, May 12). *BroadbandNow estimates available for all 50 states; confirms that more than 42 million Americans do not have access to broadband*. BroadbandNow. <https://broadbandnow.com/research/fcc-broadband-overreporting-by-state>

<sup>92</sup> Federal Communications Commission. (2020, June 8). *2020 broadband deployment report*. <https://www.fcc.gov/reports-research/reports/broadband-progress-reports/2020-broadband-deployment-report>

<sup>93</sup> Busby et al., 2021, *BroadbandNow estimates available for all 50 states*

highest level of education is less than a high school degree are home broadband users compared to 94% of college graduates. While 80% of white households have home broadband internet, only 71% of Black households and 65% of Hispanic households do. Lastly, compared to the general public, seniors are less likely to subscribe to home broadband services.<sup>94</sup>

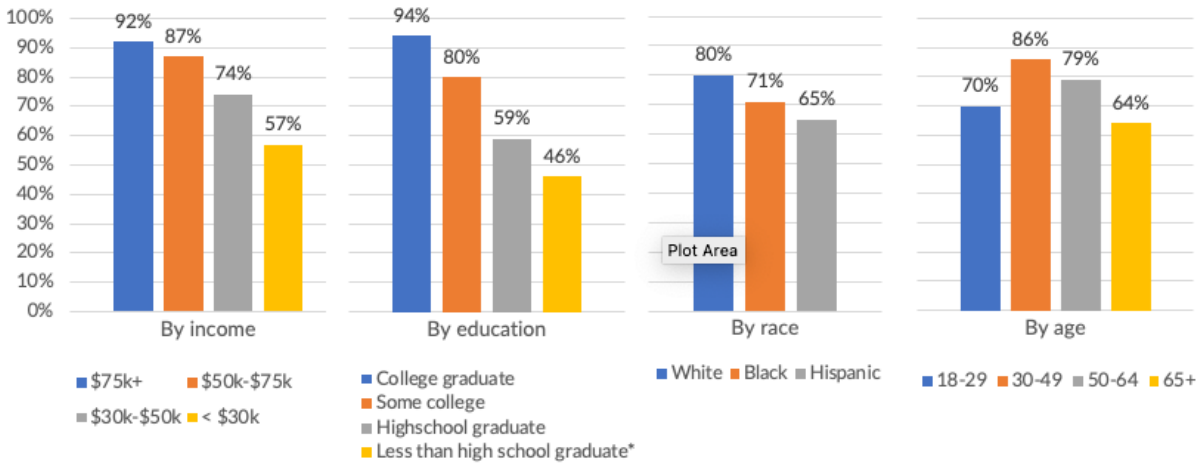

\* Based on 2019 data. Other measures are constructed from 2021 data.

Figure 20 - Home Broadband Adoption in the United States<sup>95</sup>

Despite the increased importance of broadband, cost continues to remain a barrier to broadband adoption. Only 18.5% of Iowa's population has access to a low-priced internet plan costing \$60 or less per month, which is significantly lower than the national average of 51.5% of consumers with access to a low-priced plan.<sup>96</sup> Beyond just having a broadband subscription, users need to have a range of digital skills to be active and engaged participants in digital spaces. Individuals who feel that they lack the knowledge to use broadband internet and related technologies, or who feel that they are unable to learn how to use them, will have lower adoption rates.

Gaps in access, affordability, and digital skills matter because broadband has an impact on nearly every social determinant of health. From economic stability to education to social supports to civic agency, broadband and the digital services it enables are intrinsically tied to collective health and equity outcomes. Addressing the digital divide and ensuring access to reliable and affordable high-speed broadband to underserved and unserved parts of Iowa is critical to ensuring that all residents can take advantage of the many well-documented socio-economic benefits afforded by internet connections.

<sup>94</sup> Pew Research Center. (2021, April 7). *Internet/broadband fact sheet*. <https://www.pewresearch.org/internet/fact-sheet/internet-broadband/>

<sup>95</sup> Pew Research Center, 2021.

<sup>96</sup> BroadbandNow, 2021, *Internet access in Iowa*.

## Socioeconomic Benefits

### Student Success

**K-12:** Broadband can deliver a number of educational benefits. It increases the number of learning environments; enhances educational opportunities for disabled students; provides more interactive and personalized instruction; enhances learning outcomes; and promotes the development of 21st century skills. However, there is a significant digital divide between K–12 students who have broadband access at home and those who do not – often referred to as the “homework gap.” The homework gap disproportionately affects students from families of color and rural households. According to Common Sense Media, 34% of students in Iowa lack adequate internet access, 18% of whom are Black, Latinx, or Native American. In addition, 23% of students in Iowa are without the technology and devices at home to support distance learning.<sup>97</sup> The equity implications of these gaps and impacts on learning have been brought into sharper focus as the COVID-19 crisis closed schools and ushered in the shift to distance learning.

The pandemic has shown that access to computers and the internet are critical to children’s ability to access education. A Pew Research Center poll conducted in early April 2020 revealed what is likely a more realistic nationally representative picture of homebound student experiences: roughly one in five parents with homebound school-aged children said it was very likely or somewhat likely their children would not be able to complete their schoolwork because they do not have access to a computer at home (21%) or their children must use public Wi-Fi to finish their schoolwork because there was not a reliable internet connection at home (22%). And about three in ten parents (29%) reported that it was at least somewhat likely their children would have to do their schoolwork on a cell phone.<sup>98</sup> The level of concern about the ability for their children to complete their schoolwork varied across income levels and geographies, with lower-income, rural, and urban parents more likely to think that their children will struggle with their schoolwork compared to their higher-income and suburban counterparts.

Internet access at home has repercussions that go far beyond the ability to complete homework assignments. Lack of broadband access affects student outcomes. A recent study out of Michigan State University’s Quello Center found that students who do not have home internet access, or who rely solely on a mobile plan for their internet access, perform lower on a range of metrics including digital skills, homework completion, and grade point average, even after controlling for socioeconomic factors that potentially influence academic performance. In fact, the gap in digital skills between students with no home access or cell phone only and those with fast or slow home internet access is equivalent to the gap in digital skills between 8th and

---

<sup>97</sup> Common Sense Media. (2021, March 30). *Teaching through the digital divide*. <https://www.commonsensemedia.org/digital-divide-stories#/state/IA>

<sup>98</sup> Vogels, E. (2020, September 10). *59% of U.S. parents with lower incomes say their child may face digital obstacles in schoolwork*. Pew Research Center. <https://www.pewresearch.org/fact-tank/2020/09/10/59-of-u-s-parents-with-lower-incomes-say-their-child-may-face-digital-obstacles-in-schoolwork/>

11th grade students.<sup>99</sup> This is important because a deficit in digital skills contributes to students performing lower on standardized tests such as the SAT, and being less interested in careers related to science, technology, engineering, and math. Such educational setbacks due to lack of broadband can have significant impacts on academic success, college admissions, and career opportunities.<sup>100</sup> Thus, the homework gap is no longer just about homework; it is about access to education and workforce opportunities.

**Higher Education:** The digital divide not only affects K-12 students but college students as well. Prior to the COVID-19 pandemic, college students were rarely mentioned in the digital divide as most colleges offered robust internet access across campus and many off-campus students live in high-wired neighborhoods near campus.<sup>101</sup> Despite these advantages, studies that have investigated the digital divide in higher education have found that some students, such as commuter students, remain under connected. In addition, some students may have difficulty paying their internet bill on time, struggle with data caps or outdated connection hardware, or may not be able to complete academic work due to computer performance issues.<sup>102</sup>

The potential for growing digital divides in colleges and universities became evident as institutions responded to the COVID-19 pandemic and pivoted to remote learning. According to a report by the Midwestern Higher Education Compact (MHEC), during the COVID-19 emergency shift to remote learning, approximately 16% - 19% of college students reported technology barriers (inadequate computer hardware or internet connection) that inhibited participation in online learning.<sup>103</sup> Higher rates of technology inadequacy were observed more among lower-income students (20% to 30%) than higher-income students (10% to 12%); Black (17% to 29%) and Hispanic (23% to 28%) students relative to White students (12% to 17%); and students living in a rural area (14% to 25%) compared to those living in a suburban (16%) or urban area (16% to 20%).<sup>104</sup> The same report finds that compared to students with robust internet access and reliable devices, college students with inadequate technology were more likely than their peers to agree that after the switch to online learning, coursework became more challenging, took more effort, and that they had a harder time meeting deadlines.<sup>105</sup> As shown, technology inadequacy creates an academic struggle for students and threatens their academic success. Closing the digital divide will be critical to college accessibility and student achievement.

---

<sup>99</sup> Hampton, K. N., Fernandez, L., Robertson, C. T., & Bauer, J. M. (2020, March 3). *Broadband and student performance gaps*. Michigan State University Quello Center. [https://quello.msu.edu/wp-content/uploads/2020/03/Broadband\\_Gap\\_Quello\\_Report\\_MSU.pdf](https://quello.msu.edu/wp-content/uploads/2020/03/Broadband_Gap_Quello_Report_MSU.pdf)

<sup>100</sup> Hampton, et al, 2020

<sup>101</sup> Jaggars, S. S., Motz, B. A., Rivera, M. D., Heckler, A., Quick, J. D., Hance, E. A., & Karwisch, C. (2021). *The digital divide among college students: Lessons learned from the COVID-19 emergency transition*. Midwestern Higher Education Compact. [https://www.mhec.org/sites/default/files/resources/2021The\\_Digital\\_Divide\\_among\\_College\\_Students\\_1.pdf](https://www.mhec.org/sites/default/files/resources/2021The_Digital_Divide_among_College_Students_1.pdf)

<sup>102</sup> Jaggars, et al., 2021.

<sup>103</sup> Jaggars, et al., 2021.

<sup>104</sup> Jaggars, et al., 2021.

<sup>105</sup> Jaggars et al., 2021.

## Improved Health Care

Telehealth is changing the current paradigm of health care. With its potential to increase access to care and enhance the convenience of health care delivery, telehealth can reduce health disparities for aging and underserved populations. One particular sector that has the greatest potential to benefit from increased utilization of telehealth services is Rural America. Approximately 20% of the United States population resides in rural areas (35% in the case of Iowa<sup>106</sup>) but only 9% of physicians serve these areas.<sup>107</sup> Telehealth gives rural patients access to more providers and allows them to receive care in their own communities, thereby reducing the burden of traveling long distances. For example, patients can engage in live video visits with providers for both acute and chronic issues. Telehealth also holds great potential for seniors looking to maintain their independence, low-income residents who cannot afford transportation to providers, and mobility-limited adults who cannot easily leave their homes. Remote patient monitoring, for instance, enables health care providers (especially hospitals and health systems) to collect health data from their patients each day without the logistical challenges and disruption of an office visit. Doctors can prescribe appropriate treatments and interventions, as well as help manage chronic conditions, without patients leaving their homes.

In addition to improved accessibility and favorable outcomes, telemedicine has been shown to reduce health care costs. The Veterans Health Administration (VHA) has been using telehealth technologies since the 1990s to assist in the treatment of diseases such as congestive heart failure, diabetes, hypertension, chronic obstructive pulmonary disease, and posttraumatic stress disorder. Analysis of VHA health care expenditures during 2012 showed an annual savings of \$6,500 for each patient who participated in a telehealth program. For the VHA, this equates to almost \$1 billion in system-wide savings associated with the use of telehealth in 2012.<sup>108</sup> A study by Baker et al. found that the use of telemedicine treatment for chronically ill patients was associated with spending reductions of approximately 7.7 to 13.3% (\$312 to \$542) per person per quarter.<sup>109</sup> A recent published study by Gordon, Adamson, and DeVries compared the costs of virtual doctor visits versus in-person visits and concluded that virtual health care appears to be a low cost alternative to health care administered in-person.<sup>110</sup> When all of the health benefits and economic factors are considered together, experts widely agree telehealth will continue to grow.

---

<sup>106</sup> State Data Center. (2019). *Iowa quick facts*. State Library of Iowa. <https://www.iowadatacenter.org/quickfacts>

<sup>107</sup> Mechanic, O. J., Persaud, Y., & Kimball, A. B. (Updated 2020, September 18). *Telehealth systems*. StatPearls Publishing. [https://www.ncbi.nlm.nih.gov/books/NBK459384/?report=reader#\\_NBK459384\\_pubdet\\_](https://www.ncbi.nlm.nih.gov/books/NBK459384/?report=reader#_NBK459384_pubdet_)

<sup>108</sup> American Hospital Association. (2016). Telehealth: Helping hospitals deliver cost-effective care. <https://www.aha.org/system/files/content/16/16telehealthissuebrief.pdf>

<sup>109</sup> Baker, L. C., Johnson, S. J., Macaulay, D., & Birnbaum, H. (2011). Integrated telehealth and care management program for Medicare beneficiaries with chronic disease linked to savings. *Health Affairs*, 30(9), 1689-1697. <https://www.healthaffairs.org/doi/abs/10.1377/hlthaff.2011.0216>

<sup>110</sup> Gordon, A. S., Adamson, W. C., & DeVries, A. R. (2017). Virtual visits for acute, nonurgent care: a claims analysis of episode-level utilization. *Journal of Medical Internet Research*, 19(2), e35. <https://www.jmir.org/2017/2/e35>

The continuing advancement of telemedicine and the accrual of its potential benefits to patients, health care providers, health care facilities, and the communities that house them is not possible without high-quality, reliable broadband infrastructure. Given that telehealth and electronic exchange of medical information is predicated on the ability to share information quickly across broadband platforms, known racial, socioeconomic, and geographic disparities in internet access potentially translate into barriers for the use of telehealth. In a study of nearly 150,000 patients at a larger academic health system during the early phases of the pandemic, researchers found that older age, non-English as the patient's language preference, Asian race, and Medicaid were independently associated with fewer telemedicine visits. Additionally, older age, female sex, Black race, Latinx ethnicity, and lower household income were linked with lower use of video for telemedicine visits.<sup>111</sup> In another study of nearly 8,000 patients at a single U.S. institution in the initial month of the pandemic, researchers found that telehealth was used less often by those of non-white race and those from a rural residence. Among those using telehealth, younger patients and those from a rural postal code were more likely to utilize full audio-video capability, while phone-only visits were more frequent with older patients, Blacks, and those with Medicaid, Medicare, and self-pay status.<sup>112</sup> The findings of these studies point to a digital divide, resulting from lower rates of technology and broadband adoption among older patients, rural residents, racial minority groups, and those of lower socioeconomic status.

Telehealth holds the promise of increasing access, reducing costs, and improving health outcomes. However, inadequate broadband in both rural and urban areas prevents telehealth services from reaching those who need them the most. In the long term, telehealth can increase access to all patients but only if the right investments are made to ensure equity to vulnerable populations with limited digital literacy or access, such as rural residents, racial/ethnic minorities, older adults, and those with low income, limited health literacy, or limited English proficiency.

## Economic Vitality

**Small Business:** Access to the internet is becoming increasingly important for small businesses and may be particularly important for small businesses in rural areas. High-speed internet can lead to improved matches between jobs and workers, making the hiring process more efficient. Online tools and technology can be used for operational tasks such as business banking, accounting, virtual meetings and conference calls, and cloud computing. Broadband also allows small businesses to reach potential customers outside the community, providing more opportunities for growth. In Iowa, over 10,000 small and medium-sized businesses are selling their products on Amazon, making it the top state with the greatest number of digital

---

<sup>111</sup> Eberly, L. A., Kallan, M. J., Julien, H. M., Haynes, N., Khatana, S. A. M., Nathan, A. S., ... & Adusumalli, S. (2020). Patient characteristics associated with telemedicine access for primary and specialty ambulatory care during the COVID-19 pandemic. *JAMA Network Open*, 3(12), e2031640-e2031640. <https://jamanetwork.com/journals/jamanetworkopen/fullarticle/2774488?resultClick=3>

<sup>112</sup> Pierce, R. P., & Stevermer, J. J. (2020). Disparities in use of telehealth at the onset of the COVID-19 public health emergency. *Journal of Telemedicine and Telecare*. <https://journals.sagepub.com/doi/full/10.1177/1357633X20963893>

entrepreneurs per capita selling through the e-commerce giant's online platform.<sup>113</sup> Ultimately, with access to affordable broadband technology, businesses can not only improve their efficiency but can also access advanced applications and services, all while introducing their products to new markets around the globe.

**Telework:** A key benefit of broadband for households is the ability to effectively and productively telework. Teleworking facilitates flexible work schedules, reduces travel time and transportation costs, and allows workers to live and work in their community of choice. Firms can access a larger labor pool, induce well-qualified people to a region, and facilitate employment for persons with disabilities who are unemployed or underemployed by removing barriers presented in traditional work environments. Gallardo & Whitacre note telework also has a positive impact on local median household income for both salaried and self-employed teleworkers as well as regional spillovers where spending increases beyond just the place where these people live and work.<sup>114</sup> As the pandemic disruption has shown, digital connectivity, including telework, is a valuable tool that makes communities stronger and more resilient.

**The Gig Economy:** The gig economy is a labor market characterized by the prevalence of short-term contracts or freelance work as opposed to permanent jobs. This includes everyone from online platform workers — selling items on eBay or Etsy — to drivers for Uber or Lyft, to contract nurses, to those who take a temp job. One of the biggest benefits of the gig economy is the flexibility it offers, allowing workers to leverage job opportunities that may be more adaptable to their lifestyles. Participation in the gig economy has grown rapidly over the past few years and expanded exponentially since the onset of the pandemic, due in part to the increased reliance on gig workers to deliver home necessities to consumers and as workers turned to gig work for additional – or even primary - income. Even before the pandemic hit, it was estimated that by 2023, 52% of the workforce will have worked or will be working independently.<sup>115</sup> While a key factor driving the relentless growth of the gig economy has been the increased flexibility, advances in technology are clearly accelerating this trend. Much of the gig economy is powered by the availability of high-speed internet and by innovative technological applications that enable workers to more efficiently and effectively provide goods and services to consumers. As the gig economy rises, so do the online platforms that make finding work as a gig worker possible.

**Economic Growth:** Access to broadband internet service holds the potential for boosting overall economic growth. Czernich et al. state broadband “may further facilitate macroeconomic growth by accelerating the distribution of ideas and information, fostering competition for and development of new products and processes, and facilitating the

---

<sup>113</sup> Corridor Business Editorial. (2020, August 3). *Keep Iowa ahead of online sales curve*. <https://www.corridorbusiness.com/keep-iowa-ahead-of-online-sales-curve/>

<sup>114</sup> Gallardo, R., & Whitacre, B. (2018). 21st century economic development: Telework and its impact on local income. *Regional Science Policy & Practice*, 10(2), 103-123. <https://doi.org/10.1111/rsp3.12117>

<sup>115</sup> MBO Partners. (2018). *The state of independence in America: 2018: The new normal*. [https://www.mbobpartners.com/wp-content/uploads/2019/02/State\\_of\\_Independence\\_2018.pdf](https://www.mbobpartners.com/wp-content/uploads/2019/02/State_of_Independence_2018.pdf)



introduction of new work practices, entrepreneurial activities and improved job matching.”<sup>116</sup> According to an analysis by the International Telecommunication Union, a 10% increase in broadband penetration is likely to have a positive impact and could raise economic growth by between 0.25% – 1.4%. If broadband speed is doubled, GDP may increase, potentially up to 0.3%.<sup>117</sup>

The experience of communities confirms the research. Sosa’s study of 55 US communities in nine states found a positive economic impact in the 14 communities where gigabit broadband was widely available. Those communities exhibited a per-capita GDP that was approximately 1.1% higher than that of the communities with little or no availability of those services.<sup>118</sup> According to a 10-year study conducted by economist Bento Lobo, Chattanooga, Tennessee’s fiber-optic network and electric smart grid system has led to \$2.69 billion in economic benefits and accounts for about 40% of all jobs created in Hamilton County over the last decade.<sup>119</sup> Similarly, Lafayette’s city-owned fiber network in Louisiana has “spark[ed] positive economic development throughout the region. The network has helped grow the local economy, previously dependent on oil and gas, into a diverse ecosystem that includes several new tech companies” and helped produce more than 1,300 new jobs in the area.<sup>120</sup>

For rural communities especially, the introduction to broadband access could mean significant advantages and potential opportunities. Several studies have found that broadband *availability* is an important factor for rural business location choices, housing values, and rural in-migration rates.<sup>121</sup> Other studies have found that rural areas with high broadband *adoption* rates have higher growth in household income levels, more businesses and employment, and lower unemployment rates.<sup>122</sup>

The pandemic's impacts on remote work and living preferences have created a new opportunity for rural communities to attract and retain more talent. Based on a survey of approximately 20,000 Americans conducted by Upwork in late 2020, the employment firm

---

<sup>116</sup> Czernich, N., Falck, O., Kretschmer, T., & Woessmann, L. (2011). Broadband infrastructure and economic growth. *The Economic Journal*, 121(552), 505-532.

<https://doi.org/10.1111/j.1468-0297.2011.02420.x>

<sup>117</sup> Philbeck, I. (2016). *Working together to connect the world by 2020: Reinforcing connectivity initiatives for universal and affordable access*. International Telecommunication Union.

<https://www.broadbandcommission.org/Documents/publications/davos-discussion-paper-jan2016.pdf>

<sup>118</sup> Sosa, D. (2014). *Early evidence suggests gigabit broadband drives GDP*. Analysis Group.

[https://www.analysisgroup.com/globalassets/content/insights/publishing/gigabit\\_broadband\\_sosa.pdf#:~:text=Our%20initial%20results%20suggest%20incremental,of%20first%20generation%20broadband%20technologies.](https://www.analysisgroup.com/globalassets/content/insights/publishing/gigabit_broadband_sosa.pdf#:~:text=Our%20initial%20results%20suggest%20incremental,of%20first%20generation%20broadband%20technologies.)

<sup>119</sup> Lobo, B. (2020). *Ten years of fiber optic and smart grid infrastructure in Hamilton County, Tennessee*.

[https://assets.epb.com/media/Lobo%20-%20Ten%20Years%20of%20Fiber%20Infrastructure%20in%20Hamilton%20County%20TN\\_Published.pdf](https://assets.epb.com/media/Lobo%20-%20Ten%20Years%20of%20Fiber%20Infrastructure%20in%20Hamilton%20County%20TN_Published.pdf)

<sup>120</sup> New Century Cities. (2018, February 5). *Celebrating Lafayette’s success*.

<https://nextcenturycities.org/celebrating-lafayettes-success/>

<sup>121</sup> Whitacre, B., & Gallardo, R. (2020). State broadband policy: Impacts on availability. *Telecommunications Policy*, 44(9), 102025.

Whitacre B, Gallardo R. State broadband policy: Impacts on availability. *Telecomm Policy*. 2020;44(9):102025. doi:10.1016/j.telpol.2020.102025

2020;44(9):102025. doi:10.1016/j.telpol.2020.102025

<sup>122</sup> Whitacre & Gallardo, 2020.

estimates that approximately 14 to 23 million Americans have moved recently or are planning to due to the flexibility provided by remote work. According to the survey results, those who have moved or are planning to move are twice as likely to move somewhere that is less dense and has lower housing costs.<sup>123</sup> For rural communities, each remote worker adds to the tax base and is likely to bring a partner with them - someone who could potentially work at a local company, addressing the community's primary workforce attraction objectives.

Lack of highspeed internet, however, can stifle growth and economic opportunities. Without broadband, rural businesses cannot compete as effectively in domestic and global markets as their better-connected urban counterparts. In fact, nearly 56% of rural small businesses agree that their businesses would do better if they were living in a city or urban area.<sup>124</sup> Lack of broadband infrastructure also severely impairs the potential of communities to attract new industries and develop a platform for broad-based, knowledge-driven employment in the region. Rural areas are home to 13% of all U.S. employment but only 6% of all jobs in the information and professional, scientific, and technical services sectors.<sup>125</sup> By providing the infrastructure for greater competitiveness, broadband access presents the opportunity to bring increased economic values to businesses in rural America and combat the dearth of highly skilled labor.

## Talent and Workforce Development

High-speed internet not only attracts businesses, entrepreneurs, and economic growth but also enables workers to access training and gain new skills through virtual learning opportunities. Across the nation, roughly half of all job postings are for middle-skill positions, "jobs that do not require a college degree, pay a living wage, and usually require skills in dealing with technology and people." Eight out of ten of these jobs require digital skills, and the need for digital skills is only growing.<sup>126</sup> Developing the digital workforce skills that employers require is essential for workers who are trying to advance their careers or find new employment.

Online learning is changing the way workers, businesses, and economic leaders approach workforce development. Even before the pandemic, the internet had become increasingly important for accessing and delivering education and training opportunities. From massive open online courses (MOOCs) to accelerated certificate programs to hybrid degree options from colleges and universities, online education offers flexibility to busy adult and non-traditional learners. According to the nonprofit Credential Engine, U.S. workers now have access to more than 967,000 unique credentials, stemming from postsecondary educational

---

<sup>123</sup> UpWork. (2020, October). *Economist report: Remote workers on the move*.

<https://www.upwork.com/press/releases/economist-report-remote-workers-on-the-move>

<sup>124</sup> Pham, N.D. & Donovan, M. (2019). *Unlocking the digital potential of rural America*. U.S. Chamber Technology Engagement Center. <https://americaninnovators.com/wp-content/uploads/2019/03/Unlocking-the-Digital-Potential-of-Rural-America.pdf>

<sup>125</sup> Lettieri, J. (2017, April 26). *U.S. Senate Committee on Small Business and Entrepreneurship hearing on the challenges and opportunities of running a small business in rural America*. Economic Innovation Group. <https://eig.org/news/u-s-senate-committee-small-business-entrepreneurship-hearing-challenges-opportunities-running-small-business-rural-america-2>

<sup>126</sup> Sallet, J. (2019). *Broadband for America's future: A vision for the 2020s*. Benton Institute for Broadband & Society. [https://www.benton.org/sites/default/files/BBA\\_full\\_F5\\_10.30.pdf](https://www.benton.org/sites/default/files/BBA_full_F5_10.30.pdf)

institutions (degrees and certificates), MOOC providers (course completion certificates, micro-credentials, and online degrees from foreign universities), non-academic providers (digital badges, course completion certificates, licenses, certifications, and apprenticeships), and secondary schools (diplomas from public and private secondary schools). The largest of the four provider types is non-academic providers, which are associated with 123,038 online course completion certificates and 381,561 digital badges.<sup>127</sup>

The pandemic has only accelerated and added urgency to the development of alternative pathways to career and life success. More and more learners are turning to online credentials or certificate programs to learn a specific skill set, fueling these programs' popularity and prominence. Class Central reports that through August 2020, new user growth at Coursera jumped from 8 million in the 12 months of 2019 to 20 million in eight months of 2020; EdX grew from 5 million in 2019 to 8 million in 2020, and Future Learn grew from 1.3 million in 2019 to 4 million in 2020.<sup>128</sup>

Online courses and training help workers develop skills at an unparalleled speed and scale, and since online learning can take place anywhere with internet access, the benefits it brings are particularly acute for the geographically isolated, such as residents of rural communities, and for the accessibility-limited, such as those with a disability. However, unequal access to online or technology-enabled learning means that some workers may not be able to effectively participate in skills training and as a result, miss out on future opportunities for individual economic growth and mobility. In particular, lack of broadband makes it difficult or impossible for workers to participate in video- or data-heavy online training. Without broadband, adult learners cannot familiarize themselves with the digital tools they would be called upon to use in the workforce.

The COVID-19 pandemic has accelerated the rise of the digital economy, creating a greater urgency to invest in digital upskilling and reskilling of the workforce. Digital skills are now effectively a prerequisite for many workers. Those working from home are now leveraging digital tools to succeed in the workplace on a daily basis. At the same time, in-person or frontline "essential" workers are adapting to a reality that is as contactless as possible by augmenting the usage of mobile apps, online reporting mechanisms, and related tools. Closing the digital divide will be critical to ensuring Americans have the skills to meet the changing demands of their jobs.

## Productive Farming and Agriculture

Access to broadband, and particularly the Internet of Things, promises to enhance agricultural productivity in exciting ways. Internet access allows farmers to search for new customers, find new buyers willing to pay higher prices, and identify the most affordable sources of seeds, feed, fertilizers, farm equipment, etc. Beyond that, broadband connectivity is an essential tool for precision systems that enable farmers to increase their productivity by using sensors that

---

<sup>127</sup> Credential Engine. (2021). *Counting U.S. postsecondary and secondary credentials*. Washington, DC: Credential Engine. <https://credentialengine.org/wp-content/uploads/2021/02/Counting-Credentials-2021.pdf>

<sup>128</sup> Shah, D. (2020, August 16). *By the numbers: MOOCs during the pandemic*. Class Central. <https://www.classcentral.com/report/mooc-stats-pandemic/>

collect data and help monitor livestock health, the sustainability of grazing land, crop health, and water use. With precision agriculture, farmers can save between \$13 and \$25 per acre in corn production.<sup>129</sup> The USDA estimates that full utilization of precision agriculture technologies could result in \$47-\$65 billion annually in additional gross benefit to the nation's economy.<sup>130</sup>

However, farmers need access to a robust and ubiquitous communications network to reap the benefits of precision agriculture technologies. Sensors deployed in the field, for example, need to upload data collected to a cloud-based management platform; and weather forecasting can be delivered directly to a farmer's smartphone via an app, but the farmer will need to connect to a wireless network to access the data.

Iowa is home to more than 86,000 farms but 25% of them do not have access to the internet.<sup>131</sup> To make matters even more difficult, even if a farmer's house or county has wireless connectivity, this does not mean all the acres of farm production have access. Without a wireless network that can move the thousands of data points from the installed devices to a centralized data management and analytics platform, farmers cannot fully take advantage of the efficiencies that precision agriculture can deliver. When it comes to the sustainability of small farmers in particular, high-speed internet access offers them a fighting chance to find new markets and stay competitive. In Iowa, only one in four farms use the internet to purchase agricultural supplies, and only one in three conduct marketing activities over the internet.<sup>132</sup>

Lack of ubiquitous connectivity in much of the U.S. farmlands has the potential to create a significant disparity between food producers who have access to high-speed internet in the field and those who do not. Large farms owned by agribusiness companies, which have resources to spend on building out private networks, will have one more advantage over the smaller and independent farms that are currently struggling to stay afloat.

Affordable connectivity throughout cropland and within and among farm structures (barns, cold storages, riding arenas, slaughterhouses, storage buildings) helps farms stay competitive and is critical for precision agriculture adoption and the continued availability of high-quality jobs on the farm and rural communities. Connectivity must be deployed to sustain the capacity needs of the industry now, but more importantly into the future.

## Civic Engagement

Today, it is widely recognized that digital technologies offer new ways for citizens to participate in their democracy and community. Residents can easily do things like read the news, access records online, sign petitions, make political contributions, communicate with elected officials, and even watch virtual town halls. Social media platforms, in particular, are having a profound

---

<sup>129</sup> Schimmelpfennig, D. (2016, May 2). *Cost savings from precision agriculture technologies on U.S. corn farms*. United States Department of Agriculture. <https://ageconsearch.umn.edu/record/244276?ln=en>

<sup>130</sup> United States Department of Agriculture. (2019). *A case for rural broadband: Insights on rural broadband infrastructure and next generation precision agriculture technologies*. <https://www.usda.gov/sites/default/files/documents/case-for-rural-broadband.pdf>

<sup>131</sup> United States Department of Agriculture. (2019). *Farm computer usage and ownership*. <https://downloads.usda.library.cornell.edu/usda-esmis/files/h128nd689/8910k592p/qz20t442b/fmpc0819.pdf>

<sup>132</sup> USDA, 2019, *Farm computer usage*.

impact on civic engagement and democracy. Online social networks have enabled users to find and connect with people like themselves across the globe, facilitating the development of powerful communities of individuals who may have struggled to access the same kind and level of peer support and engagement in their offline interactions. Social media has thus given a platform and voice to traditionally marginalized individuals and communities.<sup>133</sup> Social media platforms are also being used to mobilize others and show support for causes or issues. About one-third of social media users (36%) say they have used sites like Facebook and Twitter in the past month to post a picture to show their support for a cause, 35% have looked up information about rallies or protests happening in their area and 32% have encouraged others to take action on issues they regard as important (32%).<sup>134</sup> Although social media platforms are an effective tool for raising awareness and creating sustained movements, it should be noted that such platforms may also serve to misinform and polarize public opinion, rather than to educate, connect, and foster critical engagement with political issues.

Academic studies have looked at the impact of the internet on civic and political engagement and at the aggregate level, the consensus seems to be that when used appropriately, both mobile and fixed internet access may lead to higher levels of civic participation.<sup>135</sup> Further, more recent studies emphasizing the use of social networks have generally found positive relationships with various measures of social engagement.<sup>136</sup> When it comes to rural areas in particular, however, some studies show that simply providing *access* is not enough. Rural citizens are already typically more engaged in their communities than their urban counterparts. Thus, what matters the most for boosting many metrics of civic engagement such as joining a civic or local organization, participating in a discussion on critical issues, or contacting a public official to express an opinion, is internet *adoption*.<sup>137</sup>

Broadband contributes to a more engaged and informed electorate in an age when the internet has become an essential component of American politics. Gaps in broadband coverage impact the civil lives of affected Americans by limiting or preventing opportunities for political engagement. Beyond creating infrastructure to increase broadband access, encouraging adoption, both through policy and local support systems, can, in turn, lead to more civic participation, particularly across rural America.

As the COVID-19 crisis has shown, digital technology is playing an important role in providing opportunities for social connection and networking. From graduation ceremonies and church services to weddings and funerals, social media and video platforms have helped people share

---

<sup>133</sup> Dubow, T., Devaux, A., & Manville, C. (2017). *Civic engagement: How can digital technology encourage greater engagement in civil society?* RAND Corporation.

[https://www.rand.org/content/dam/rand/pubs/perspectives/PE200/PE253/RAND\\_PE253.pdf](https://www.rand.org/content/dam/rand/pubs/perspectives/PE200/PE253/RAND_PE253.pdf)

<sup>134</sup> Auxier, B. (2020, July 13). *Activism on social media varies by race and ethnicity, age, political party*. Pew Research Center. <https://www.pewresearch.org/fact-tank/2020/07/13/activism-on-social-media-varies-by-race-and-ethnicity-age-political-party/>

<sup>135</sup> Whitacre, B. (2017). Fixed broadband or mobile: What makes us more civically engaged?. *Telematics and Informatics*, 34(5), 755-766. <https://doi.org/10.1016/j.tele.2017.02.006>

<sup>136</sup> Whitacre, 2017

<sup>137</sup> Whitacre, B. E., & Manlove, J. L. (2016). Broadband and civic engagement in rural areas: What matters?. *Community Development*, 47(5), 700-717. <https://doi.org/10.1080/15575330.2016.1212910>

their important moments and maintain a sense of community. Alternate means of connectivity have become especially critical for vulnerable populations. Older adults face unique risks of social isolation and loneliness owing to a multitude of factors, including retirement, losses of spouses/partners and other loved ones, and changing health and functional status. Social isolation has been linked to negative health outcomes, reduced quality of life, and premature death.<sup>138</sup> With COVID-19 hitting the elderly population hard, particularly those in group settings such as nursing homes and assisted living facilities, communicating over broadband-enabled technology can reduce the sense of isolation.

Limited access to broadband internet and cellular activity, however, can make it harder to connect online or reach people. Although dated, a 2012 report by Connect Iowa showed that only 27% of Iowans age 70 and older subscribe to broadband.<sup>139</sup> Recent data from the Pew Research Center show that older Americans lag younger by double-digits on a range of technology measures—internet use (23% gap); smartphones (25% gap); tablets (19% gap); and social media (35% gap).<sup>140</sup> Such technology barriers can further reduce the quality of life for older adults who are already challenged by other socioeconomic and health factors. Research from the nonprofit Older Adults Technology Services found correlations between digital disengagement and race, disability, health status, educational attainment, immigration, rural residence, and income.<sup>141</sup> Such findings show lack of internet access at home threatens to widen already serious divides between the privileged and disadvantaged.

During the COVID-19 pandemic, access to broadband has been important to blunt the impacts of social isolation and bolster social connectivity. Social networks such as WhatsApp and Facebook can help reduce the social isolation of the most at-risk populations already suffering from loneliness. Furthermore, platforms such as Skype, Facetime, or Zoom can introduce these populations to online communities who share common interests or help them stay connected with friends and family. Digital technologies have the potential to bridge distances and increase social connectedness but only if affordable broadband access is available and users have the necessary digital skillset to make use of the internet.

## Conclusion – Broadband and Post-Pandemic Normal

Decades into the digitalization of the American economy, broadband directly or indirectly touches every individual, every day. From employers who rely on digital communications, to students who attend classes online, to governments who communicate with residents through online portals, society is quickly integrating broadband service into a seemingly endless array of activities that drive economic prosperity and health outcomes. The more important broadband

---

<sup>138</sup> Centers for Disease and Healthy Aging. (2020, November 4). *Loneliness and social isolation linked to serious health conditions*. <https://www.cdc.gov/aging/publications/features/lonely-older-adults.html#:~:text=Recent%20studies%20found%20that%3A,percent%20increased%20risk%20of%20dementia.>

<sup>139</sup> Connect Iowa. (2012). *Iowa's silent generation: Resilient, more experienced, but disconnected*. [https://connectednation.org/wp-content/uploads/2018/12/iowa\\_elderly\\_technology\\_adoption.pdf](https://connectednation.org/wp-content/uploads/2018/12/iowa_elderly_technology_adoption.pdf)

<sup>140</sup> Anderson, M. & Perrin, A. (2017, May 17). Tech adoption climbs among older adults. Pew Research Center. <https://www.pewresearch.org/internet/2017/05/17/tech-adoption-climbs-among-older-adults/>

<sup>141</sup> Older Adults Technology Services. (2021). *Ageing Connected: Exposing the hidden connectivity crisis for older adults*. [https://agingconnected.org/wp-content/uploads/2021/02/Ageing-Connected\\_Exposing-the-Hidden-Connectivity-Crisis-for-Older-Adults.pdf](https://agingconnected.org/wp-content/uploads/2021/02/Ageing-Connected_Exposing-the-Hidden-Connectivity-Crisis-for-Older-Adults.pdf)

connections become, however, the more disadvantaged are those who cannot use broadband, either because no service is available, they cannot afford connections to their home, or they do not yet have the needed digital skills. Thus, it is critically important to address this digital divide. Broadband is a fundamental prerequisite for full participation in modern life and a basic requirement for access to opportunities that make success and prosperity possible for individuals and communities. We simply cannot afford to leave so many people behind as new technology breakthroughs improve quality of life and drive new levels of opportunity and progress.

## Public Policy

Public policy and permitting processes plays a key role in the deployment of broadband infrastructure. Communities can either take a “defense” or “offense” position or some of both. Defense entails protecting Right of Way when it is becoming congested, maintaining aesthetic standards, etc. An offense approach to policy is used when working on ways to attract broadband or new technology.

Both defense and offense can take different forms within policy and permitting. Restrictions, fees, added complexity or other steps that make deployment more expensive are all examples of defensive policy. Policy components that make the permitting process faster or have ways to reduce deployment costs can encourage providers to deploy in certain areas and are, thus, considered geared towards offense.

With this distinction in policy approach, it is important for communities to:

- Be clear on what approach they are utilizing – defense, offense or a mix. These positions need to be by decision and intentional
- Ensure that their broadband related policies match their broadband related goals. If a community wants to attract broadband investment, but their policies make the process more complex or adds costs, then the policies could be a strong impediment to the broadband related goals
- Engage the providers in the area for their feedback on policy - particularly if the community is trying to encourage broadband deployment.

There is a common thought process that communities and providers are on opposing sides. Communities do need to be good stewards of public RoW, aesthetics and public safety, but it is important to also understand that providers have finite amounts of dollars to invest in new infrastructure. Things that make deployment more expensive can either reduce the scope of the deployment or encourage a provider to build in a different place that is less expensive.

A more thorough discussion of broadband related policy is included in a whitepaper in Appendix D and the Governors’ Council Recommendations in Appendix F.

Two policy related tasks were part of this study: A meeting with providers to get their feedback and recommendations for policy and a work session with community leaders. In the meeting with the providers, they were engaged and offering the following recommendations (also listed in the Provider section of this report):

- Differing types of construction have significantly different costs. For example, if aerial placement is prohibited or boring is required
- Funds for new construction are limited, so the tradeoffs are to either have smaller builds, fewer service points, or move to other areas
- Rigidity on fiber placement – important to work together on where the fiber will go so that it is the most economical and meets real community needs can help a build go faster and be more affordable



- Having to move existing infrastructure can happen, but it is expensive and would be much better to plan ahead over the next few years. Then it could be possible to reduce the need for moves, saving funds that could apply to building out new infrastructure. The example was given of a provider putting in new service only to have to move a lot of it the next year because of a project that was in the plans, but not discussed with the provider
- If one community has requirements that increase costs, that another community does not, then sometimes it makes sense to build in the less expensive community
- Greater availability of municipal conduit – if conduit is available, providers would like to discuss terms to see if it will be a safe, less expensive way to deploy – they are open to those discussions, the details will be the deciding factor. Also, the providers would suggest having more than one conduit, given that there are cost savings in multiple conduit builds; and if conduit is going in, it is better to not run out of capacity and options in planning how to provide better service
- Speed to market matters – so, if communities have preferred paths that are faster to deploy, providers will look at those (assuming they meet deployment plans)
- Long decision times, including those involving council meetings or State approval, can add months to a build schedule. So, options like preferred paths that are already approved or expedited processes can make a build more attractive
- Providers come to the table with certain amounts of money for new service – they want to work with counties and cities to make those dollars go as far as possible and to make the deployment process as predictable as possible – those really is in everyone’s best interests

The public policy workshop was held September 16 with county and city leaders to clarify the connection between broadband deployment and policy. In that workshop, the recommendations from the providers were presented and the following topics were discussed.

### **Why Policy Approaches Are Important**

- It is important for public entities to explore improving broadband service. In rural areas, that is likely access through more and better providers. In urban areas, it may be adoption programs.
- Private sector partners want to bring needed services but are bound by economics on how and where they can deploy.
- Public policies can either attract or repel investment.
- Providers are making economic decisions based on ROI or even time to market.
- For hard-to-serve/remote areas, policy decisions and even public investment in grants, colocation and even streamlining permitting processes can tip the scales toward a provider deploying in one area or choosing another area.

Also, specific types of policies were discussed:

### **Colocation Policies**

These can apply to both wired and wireless infrastructure (E.g., conduit, fiber, small cells)

- Joint-build Initiatives with the private sector
- Synchronize scheduling of deploying assets
- Save expenses of digging with coordinated builds, less traffic congestion, faster deployment
- Require builders with open trenches and boring projects to deploy conduit and/or fiber on behalf of the community

For a sample policy, see Appendix B.

### **Wired (Fiber): Dig Once / Shadow Conduit**

When new roads are being built or opened for maintenance and conduit is not already in place, “dig once” policies that involve the installation of an oversized conduit bank within the right-of-way to accommodate future users— reducing the need to tear up the streets each time a new broadband provider wants to bring service to an area.

### **Wireless: One-Touch Make-Ready**

Many broadband cables are installed using the power infrastructure already in place. The process to make a pole ready is usually: a new broadband provider negotiates access to poles in a given area, then waits until other providers or entities that have equipment attached to those poles to move their equipment one after another.

With one-touch policies, governments can ensure that the installation of each line – power, telephone, and internet – takes future use into consideration.

### **Incentivizing Deployment Within Preferred Public Right-of-Way Locations**

Openly Available GIS map of Preferred Locations:

- Preferred RoW corridors
- Building rooftops
- Poles and intersections
- Available for leasing existing shadow conduit or dark fiber

Exploring street cut and pavement degradation fee exemptions and other complementary initiatives

- Pavement degradation policy
- Street cut fee policy

- Traffic control policy

This can result in expedited permitting process and faster time to market

### Microtrenching

Microtrenching is the process for deploying fiber that cuts thin, shallow channels into pavements, sidewalks, or existing joints, in lieu of wider, deeper trenches or underground bores. Microtrenching pros and cons include:

- Less expensive Alternative
- Improved public safety, lower likelihood of striking other buried infrastructure
- Reduced disruption in the Rights-of-Way
- Some cities ban it due to pavement degradation, but areas where it is acceptable can be identified

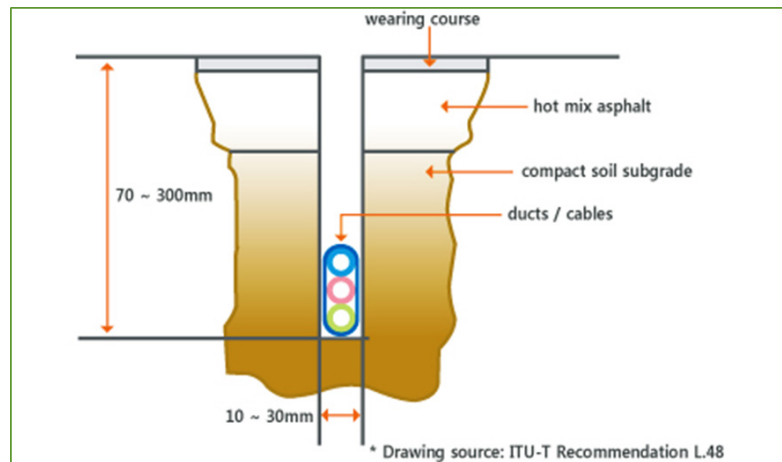

Microtrenching can be an example of tradeoff between departmental vs. citywide objectives.

# Potential Risks of Strategic Broadband Approaches

## Introduction to Risk Mitigation

In communities across the US, the realization that broadband is a determining factor in global economic participation has never been more apparent than it is right now. The COVID-19 pandemic has served as a catalyst for communities to kick start initiatives to deploy long needed broadband in unserved and underserved populations. It is commendable that communities are taking their broadband future into their own hands, but these projects are not without inherent risk. In this document, HR Green will provide a process to identify risks, quantify the probability and severity of the risk, and propose a plan to handle the identified risk.

### Is the Risk Worth the Reward?

The new emerging standards for 5G and increased need for high-speed bandwidth is ushering in a new age of technological advancement that will change the way we interact with each other and our perceivable environment. These include augmented reality; autonomous vehicles; IOT; automated, mobile robotics for factories and distribution facilities; Smart City applications; telemedicine, and virtual classrooms just to name a few.

Currently, in most communities the low latency networks required for these applications are virtually nonexistent and it is not in the financial interest for incumbent Internet Service Providers (ISP's) to build or upgrade their existing networks. Private companies are not beholden to improve the social and economic outlook of communities they serve and that is why it is so important for local communities come together to solve the issue of broadband access.

Other than the above-mentioned end user applications, there is a huge economic incentive for communities to develop broadband networks. According to a recent study by the University of Tennessee on a fiber optic network deployed in Hamilton County found the following after ten years of operation: "Our estimates show that the economic value of the fiber optic infrastructure, i.e. high-speed broadband and the smart grid, minimally exceeds \$2.69 billion and 9,516 jobs over the study period." They go on to explain, "Roughly 40 percent of all jobs created in Hamilton County in the study period can be attributed to the fiber infrastructure."

Other than the regional economic and commercial drivers there is another economic boon for regions that deploy fiber. Recent studies have shown that a home with a fiber connection can increase the value of that home up to 8%. For prospective home buyer's connectivity is second only to safety when selecting a neighborhood, according to a recent study by the Fiber Broadband Association.

We live in a world where technology advances at incredible rates and in many cases economic and social success hinges on access to the technologies that drive markets. Without a robust broadband infrastructure these opportunities and markets will be unattainable. Businesses and consumers require access to broadband when making decisions about relocating or staying in a community.

Ultimately, we believe the risk for communities is manageable and worth the reward. The impacts of lack of broadband access are visible across rural America. Before the pandemic, countless towns in the US were experiencing an exodus of businesses and residents. The pandemic has shifted priorities for many, and they are looking for communities outside of urban centers. Small town America is being provided a second chance but in order to seize that opportunity action is needed. High-speed broadband is paramount to capitalizing on the opportunity that has presented itself for communities suffering from lack of access.

Throughout this document we will provide a process to address the risk that is inherent to a broadband deployment. Large public improvement projects can be daunting, but most municipalities have experience in some sort of infrastructure deployment. Overall, the risks are similar for a broadband project with some caveats. HR Green believes that selecting the proper partners and extensive detailed planning will lead to fewer risks and a higher probability of achieving the project goals.

## **Risk Categorization**

One of this project goals is to minimize the potential for deviations from the established plan in the implementation phase. Our project management strategy includes a formal assessment of potential risks using a matrix and a registry to assess, monitor, and manage specific risk categories. These are reviewed and updated as necessary during the lifecycle of the project.

The project management team implemented brainstorming and research for risk identification, categorization, and analysis to assess and manage specific risk categories, risk prioritization based on a quantitative score and priority number, and advanced planning for appropriate response and control.

We categorize these risks in groups of External, Management, Organizational, Technical, and Environmental:

- External risks include contracts and agreements that delay the project, such as community opposition or safety concerns.
- Management risks include the project requiring more work or cost than anticipated.
- Organizational risks include a lack of consensus among stakeholders regarding goals, outcomes, and delivery.

- Technical goals include faulty equipment or facilities that break during or after construction.
- Environmental risks include compromise of resources and facilities due to weather-related events or other causes.

### Risk Probability and Impact Matrix

	Likelihood				
Consequence	1	2	3	4	5
	Rare	Unlikely	Possible	Likely	Almost certain
5 Catastrophic	5	10	15	20	25
4 Major	4	8	12	16	20
3 Moderate	3	6	9	12	15
2 Minor	2	4	6	8	10
1 Negligible	1	2	3	4	5

Our deliverables include a Risk Matrix and a Risk Registry. The Risk Matrix evaluates every risk within several levels of Likelihood and Consequence scores and identifies each risk’s priority level. The Risk Register considers each risk’s impact and probability level and informs its risk score. Each risk also has identified triggers, remediation plans, and responsible parties for its mitigation.

### Define the Risk Probability, Severity, & Proximity

In the risk register example on the Next page, the project rates each identified risk on a quantified risk score and corresponding priority level (high, medium, low) based on its impact and probability. Both Priority and Probability scores are rated on the scale of 1 to 5 depending on research and analysis.

In analyzing options for risk resolutions, including avoiding, transferring, mitigating, exploiting, sharing, enhancing, or accepting the risk, the risk score determines the strategy. High risks (multiplicative product above 15) are watched closely and routinely discussed, medium high risks (between 8 and 15) are continuously monitored and mitigated, medium low risks (between 4 and 6) are periodically monitored and remediated when necessary, and low risks (3 or below mitigated as they) are occur.

## Example Risk Register

Risk ID #	Category	Risk Description	Impact/Consequence/Severity	Probability/Likelihood	Risk Score (Likelihood x Consequence)	Detectability (1-5) (Faster to detect=1)	Risk Priority Number (RPN) (Risk Score x Detectability)	Risk Triggers	Remediation Plan	Risk Ownership
	Technical	Lack of Technical Knowledge	3	2	6	2	12			
	Organizational	Inaction on Any Broadband Initiatives	5	1	5	1	5			
	Management	Lack of Allocated Resources	5	3	15	3	45			
	Technical	Poorly Defining Effective Broadband Metrics	3	2	6	4	24			
	External	Loss of Public Support	5	2	10	3	30			
	External	Political Pushback from Incumbent Providers	3	3	9	3	27			
	Management	Financial Sustainability	5	4	20	4	80			

## How to Deal with the Identified Risks

### Strategies for Overall Project Risk:

**Avoid** -Where the level of overall project risk is significantly negative and outside the agreed upon risk thresholds for the project, an avoid strategy may be adopted. This involves taking focused action to reduce the negative effect of uncertainty on the project as a whole and bring the project back within thresholds. An example of avoidance at the overall project level would include removal of high-risk elements of scope from the project. Where it is not possible to bring the project back within the thresholds, the project may be canceled. This represents the most extreme degree of risk avoidance, and it should be used only if the overall project level of threat is, and will remain, unacceptable.

**Exploit-** Where the level of overall project risk is significantly positive and outside the agreed upon thresholds, for the project, an exploit strategy may be adopted. This involves taking focused action to capture the positive effect of uncertainty on the project as a whole. An example of exploiting at the overall project level would include addition of high benefit elements of scope to the project to add value or benefits to stakeholders to embrace the opportunity.

**Transfer/Share-** if the level of overall project risk is high but the organization is unable to address it effectively, a third party may be involved to manage the risk on behalf of the organization. Where overall project risk is negative, a transfer strategy is required, which may involve payment of a risk premium. In the case of high positive overall risk, ownership may be shared in order to reap the associated benefits. Examples of both transfer and share strategies for overall project risk include but are not limited to setting up a collaborative business structure in which the Project owner and the vendor share the overall project risk, launching a joint venture or special purpose company, or subtracting key elements of the project.

**Mitigate/Enhance-** these strategies involve changing the level of overall project risk to optimize the chances of achieving the project's objectives. The mitigation strategy is used where overall project risk is negative, and enhancement applies when it is positive. Examples of mitigation or enhancement strategies include replanning the project, changing the scope and boundaries of the project, modifying project priority, changing resource allocations, adjusting delivery times, etc.

**Accept** - with no proactive risk response strategies possible to address overall project risk the organization may choose to continue with the project as currently defined even if overall project risk is outside the agreed upon thresholds. Acceptance can be either active or passive. The most common active acceptance strategy is to establish an overall contingency reserve for the project, including amounts of time, money, or resources to be used if the project exceeds its threshold. Passive acceptance involves no proactive action apart from periodic review of the level of overall project risk to ensure that it does not change significantly.

#### **Identified Risks and Strategies:**

1. **Lack of Technical Knowledge:** One risk for county and city leadership could be lack of technical knowledge (or operational knowledge). There is likely some concern about whether they could operate and maintain any fiber infrastructure they might build or incentivize or have the knowledge to negotiate with and best help provider network expansion.
2. **Risk Strategy: Transfer/Share** – In the case of an organization taking on a large public improvement project such as municipal broadband, the skill level covers a vast amount of categories of Specific Knowledge, ranging from engineering, construction, IP Networking, Manufacturing, Sales, etc. Most Municipal governments do not staff the



appropriate amount or in some cases the employees that have the knowledge to plan, implement, manage, and complete the tasks necessary for successful project delivery. In this case, transferring that risk or sharing that risk with a third party is the most effective way address this type of risk. It could be possible to hire employees with the needed knowledge, but that would take a clear definition of roles and expertise.

One area that communities could help providers is in grant writing. There is (and will continue to be for the foreseeable future, a need for grant writing.

3. ***Lack of Continuation of Next Steps:*** This risk falls into two categories:

- Gap data being kept current: As projects are completed and broadband improvements are made, it will be easy to lose track of the ongoing needs. Keeping an ongoing collaborative provider gap awareness program going will require provider(s) or public funding sources. Which means there needs to be commitment by both to allocate existing customer and taxpayer/economic development funds to maintain accurate gap data - at a regional level. As basic service gaps get filled, there will be a propensity for any particular provider and community to end funding. Leaving a dwindling base from which to maintain a revenue stream for the data maintenance project for the hardest to serve areas towards the end of the deployment cycle.
- Funding and focus on areas with needs: As with the data, as projects are complete, the clarity on needs can become less focused. This can leave the areas missed for access or adoption needs in the same position they are now – with less resources to improve their connectivity.

***Risk Strategy: Transfer/Share*** – The entity to maintain the data and focus should be identified and equipped to keep the broadband improvement answers moving forward. This could be within Greater Des Moines Partnership, another entity like a regional economic development organization or a private partner.

4. ***Poorly Defining Effective Broadband Metrics:*** The definition of high-quality broadband will continue to expand over time as both supply sources (technological) and demand applications grow. Measures of being successful in price, latency, outage frequency, and repair times will become tighter between high-quality and low-quality. How to define "good enough" at any point in time, that warrants ongoing collaborative efforts to improve areas in the region to the "next level", may prove challenging over time. Nationally, that point was reached in 2020 but the seeds of the problem were sown in the mid-2000's through inaction by most, which seems to be the nature of the market.

***Risk Strategy: Accept/Mitigate***– There are two levels of this issue: Federal and State. While the defined broadband speeds from the FCC are far below what the true meaningful speeds of broadband, at a project level there is not much that can be done

to change that FCC threshold. By adopting a 100/100 Mbps (100/20 Mbps for rural and remote areas), the State of Iowa has adopted a program that continues to increase speeds in accordance with regional needs, largely eliminating this risk

5. **Loss of Public Support:** Public support can take many forms in broadband. One area is in support of the community being involved in broadband projects. This could either come from concern over dollars being spent or from political stances. Another source of support or lack of support can come from customer experience. Any deficiency from a given technology or from a particular provider's performance may reflect poorly on the overall project. Once the public expresses their concerns, next steps for the community leadership or providers may become more challenging. And ever-rising expectations may not get filled, so public support for ongoing efforts can erode over time.

**Risk Strategy:** Transfer/Share – Low public support can be overcome in multiple ways. One avenue is to intentionally work to set expectations of the public. If they are in a remote area, solutions will be limited and likely in line with the approach outlined in the Technology Section of this report. Helping them to understand those issues can help offset the challenges of reaching them. Another example of managing expectations is to help community members clearly understand the role of the community public sector and what county or city leadership will be doing and what they will not be doing (and why). Also, from the implementation side, partnering with experienced vendors and Partners that focus on customer relations can help with the service customers receive. This can be transferred to the partner themselves or a PR firm can be brought in. The best strategy for this identified risk is proper planning, communication and extensively vetting of partners/vendors in order to avoid poor public perception of the project or the service provided thereafter.

6. **Political Pushback from Incumbent Providers:** The relationship between communities and providers can be confusing and challenging from both sides. Communities have interests of managing RoW, having broadband that meets citizen and economic development needs, managing aesthetics, etc. Providers have profit models and business formulas that drive their resource allocation and deployment decisions. When those interests conflict, some communities have passed strict controls on telecommunications permits and installations. Also, some providers have not shied away in the past from using their political capital against the region's broadband efforts at the State and local levels. There can be a tension between who is underserved and unserved and how those customers can be reached. These legal and financial issues could determine where providers will build (leaving some citizens unserved) or shift mid-deployment, leaving continued gaps.

**Risk Strategy:** Exploit – leaders in the region can exploit (take action in) the current setting by continuing to invite providers to be partners in the project. This has been begun with three provider meetings during this study. Inviting all the incumbent provider to the table to be equal partners gives them the possibility of being part of the

discussion and solution. Providers might have different approaches to this, but building relationships, working through areas of tensions and collaboratively working to find the win/wins can go a long way towards mitigating this risk.

7. **Financial Sustainability:** There will be financial risks for providers, lenders and investors in any proposed solutions. Refinancing ability, default processes, and backstops can mitigate many, but in the end, there will be some stranded assets due to either technology changes, provider-level finances, property owner deficiencies, community-level decline, and macro-level regional recessions over the life of any financing. So, tolerance for those losses needs to be built into the financing equation.

**Risk Strategy: Transfer/Share** – Partnering with qualified vendors who understand the market condition and capitalization of broadband networks is paramount. There is a significant amount of planning that goes into broadband deployments and having a qualified financial partner is as important as a qualified engineering and construction partners. There is no way to fully transfer the financial risk as the project owner, but the risk can be shared by structuring the project in a way that provides the best path for ongoing financial stability. Winning grants can also be a key ingredient in the financial success of projects. It should also be kept in mind that providers have to match most grant dollars. Because of that, they might be limited in the projects they can do.

8. **Low adoption of broadband when available:** When broadband becomes available to consumers, adoption may be slow or non-existent due to current desires, habits, device availability, training, accessibility issues and economics. The lack of broadband usage will adversely diminish the quality of life and economic benefits which is well understood with broadband. Should consumers not adopt available broadband, there will be lower subscription revenue to cover the cost of maintaining the service.

**Risk Strategy: Mitigate/ Enhance** – Mitigating this risk goes back to detailed planning and outreach. The project owners and Partners need to clearly communicate with the potential customers to not only inform them of the project but to educate them about what that means, and garner feedback from the customer. Learning the issues they face may help the project owner develop a more effective plan to reach those individuals. There are government programs to help with adoption (the City of West Des Moines has instituted a program to help link needs with these resources). And, working with agencies who can help with financial issues, not understanding the technology, language barriers, etc. can help with adoption.

9. **Inaction on any Broadband Initiatives:** there are inherent risks with any broadband deployment project, but in many cases, there is an even greater risk for communities that lack broadband access. The fact is that access to high-speed broadband is vital in order to participate in the global economy. Broadband is an engine of economic development and will continue to be a resource that attracts business and skilled individuals to communities. Conversely the lack of that resource will drive out

businesses and contribute to the exodus of younger populations who are seeking better economic opportunities. In short, communities that do not act will see the digital divide widen and will not be able to reap the benefits of the growing 5G/Digital economy.

**Risk Strategy:** Avoid- Communities can avoid this risk through several steps. The Government Recommended Practices in the Recommended Practices section of this report defines bulleted steps a community can take to continue to improve broadband. Examples of those steps are engaging the private sector, utilizing the State arrangement with Fiber Utilities Group, work with regional broadband groups, work with consultants to help with specific next steps, etc. Someone or a group are needed to champion the broadband cause and to continue to take planned steps.

## Ongoing Measurement of Progress

As this process changes from a study to next steps, there are some best practices that can be put in place as ongoing measures of progress. The following bullets are meant to provide the basis for a checklist in a process of monitoring next steps that are taken.

### **Process/Structure for Setting Regional Broadband Digital Inclusion Goals (Key Performance Indicators – KPIs)**

1. Access: Unserved, underserved, and fully served by urban, rural, and remote Central Iowa Broadband Internet Study constituents has begun to be quantified and documented. Continuing to update this data, particularly as projects are completed will help keep focus on other projects to continue to improve broadband across the region. A map and/or metric can be developed to keep a visual track of where access is being improved and where it still needs work.
2. Adoption: Maintaining a focus on those who have not adopted available networks is important to refine the approaches to working with those with adoption challenges. Ways to reach those individuals and measure their increased adoption will help focus efforts. Also, monitoring participation in adoption-promotion programs and funding can help see what is effective and ineffective in those programs and efforts.
3. Provider success in capital attraction to construct networks meeting unserved, underserved, and fully served demand. In NOFA#6, the 11-county study area received less than would be expected. Having a KPI that continues to measure both the success of grant awards, but also reasons why these 11-counties do not receive awards could be significant in improving the amounts of grants that come to Central Iowa

### **Developing Potential Joint Action/Collaborations**

There are opportunities for collaboration that could have significant impact for broadband in Central Iowa. These organizations and potential collaborations all have an interest in better broadband and bring unique knowledge and skill sets to this discussion. Examples of these types of opportunities could include:

1. Collaborate on Greater Des Moines area programming
  - Public Libraries
  - Public Schools
  - AEA
  - Community College
  - Community Broadband Action Network working group specific to Greater Des Moines
2. Host an annual Greater Des Moines regional broadband summit
  - Provider participants and sponsors
    - Provider associations
    - Technology Association of Iowa
  - Consumer Advocacy and Market Development participants
  - Public Sector and Economic development participants
  - Financial capital sponsors
3. Public entities/collaborations: Financing digital inclusion using public funds

Regional groups of public sector entities can have ongoing collaborations to work through the following possibilities:

- Goal-driven outcomes to set strategic direction
  - Data-driven priority target areas
  - Transparency on selection criteria and process
  - Provider agnostic
  - Collaborative approach to logical network extensions – middle mile or last mile
  - Flexible technology approaches based on economics
  - Monitor demonstrated provider capacity to serve the customer and upgrade technology over time
4. Monitor progress towards goals – having a structure and benchmarks can help keep broadband improvement moving forward. Some examples of this could be:
- Annual report progress at a regional broadband summit
    - Urban regional areas
    - Rural regional areas
    - Remote regional areas
  - For communities - participation in the forthcoming State of Iowa Broadband and Remote Workforce-Ready Certification Program
    - Public sector reviews and reports semi-annually on community-level availability and continual improvement plans, especially when new areas of the political subdivision that need broadband are identified or built.
    - Certification compliance
      - Demonstration of support and commitment
      - Resolution adopted by the political subdivision designating point of contact and local officials/agencies.
      - Meeting minutes of local “Providers Council” or similar local group with participation by those named in the resolution.
      - Submission of local goals and extenuating circumstances by the designated local economic development officials/agencies named in the resolution.
    - Electronic filing or tracking of applicable existing and proposed ordinances based on those established as best practices.
    - Certification that the local political subdivision does not choose final contractor(s), impose fees above \$100, impose a moratorium, discriminate among providers, require service as a condition of a permit, or require other fees.
    - Submit performance goals and metrics, based on information and data summaries from individual political subdivision submissions, to report to the Authority that help determine the successfulness of the certification programs.
  - Provider collaboration meetings with communities and providers – these could be at the County level or regional level (or both)
5. Evaluation and External Marketing
- Periodic Central Iowa Broadband Internet Study area updates by 3rd party on economic development impacts of increased broadband access and adoption (monitor competitiveness)
  - Integrate updates with The Partnership and local economic development marketing efforts

- Integrate core messaging about local certification participation and status into State of Iowa and local political subdivision marketing platforms and campaigns.

**Policy** (Ensuring it Meets Broadband Goals) – see policy section – this is just a highlight

- Expedited routes – have routes that providers and permit agencies agree on that can have a faster permit process
- Dig once (colocation) – have the option for the permit agency to add conduit during any construction projects in the ROW and for structures for microwave
- ROW Management – developing a clear map of road segments that, either because of natural issues or because of prior utility deployment, are running out of available ROW. These policies can clarify what is needed to create more ROW capacity

**Risk Mitigation** – see the Risk Mitigation section for details on evaluating risk. Moving forward, each county or at a regional level, it would be helpful for participants to discuss the specified risk factors (and any others that develop) to continue to lessen risk and solve the problems that produce the risks.

# Recommended Practices

## Government Recommended Practices

This set of Recommended Practices is provided for the county and city governments and public agencies in the Central Iowa Study area.

Broadband is critical infrastructure for economic development, working from home, education, telemedicine, ability for seniors to stay in their homes, keeping youth in a community and many other quality of life applications. The COVID-19 pandemic showed the degree to which connectivity has become a necessity in many aspects of our lives. Additionally, the level of importance of good broadband has also made clear the challenges faced by those who do not have access (broadband infrastructure being available) or have struggles with adoption (choosing to become a customer when it is available).

As the study showed, there are broadband access and adoption challenges in the Central Iowa Broadband Internet Study area. For governmental agencies to take steps to improve broadband, the following Recommended Practices are listed.

### DETERMINE THE ROLE YOUR GOVERNMENT AGENCY SHOULD HAVE

Counties and cities have a wide array of options that could be pursued to improve broadband.

- Access – ways your agency can impact the availability of broadband infrastructure. This chart shows the different ownership and governance options that are available.

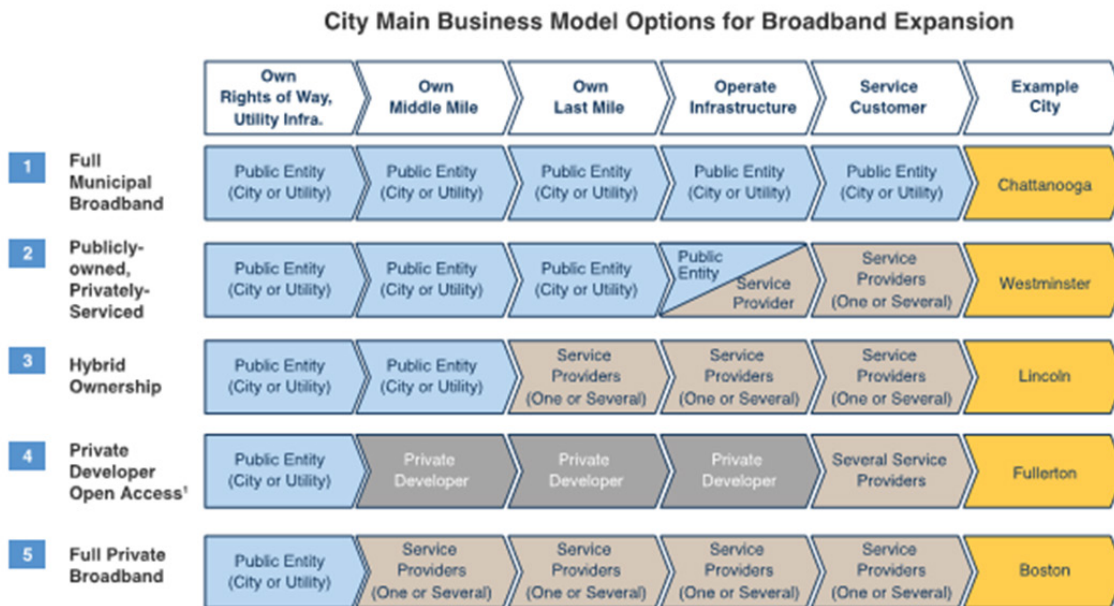

Note: 1) Private Developer is defined as private company that builds, owns and operates the network infrastructure and offers open access to it to several retail SPs that provide service on the top



- Ownership options
  - Own, operate and maintain a full network – fiber or wireless infrastructure
  - Own a full network, but hire a private company to operate and/or do maintenance
  - Own broadband infrastructure that makes it less expensive for providers to extend their networks (conduit, towers, etc.). The agency can either maintain or hire a private company to maintain
- Active facilitation of private investment –
  - Help providers with grants
  - Actively work with providers – monthly coordination meetings
  - Help further define needs for future grants (to improve the grant application or challenge State or federal broadband maps)
  - Provide funds to facilitate deployment or for grant matches
  - Policies – ensure policies support broadband goals (see below)
- Passive access and/or adoption – very limited involvement, allowing the private sector to address broadband issues
- Adoption – ways your agency can help customers connect to available infrastructure
  - Informational – continue to help define adoption barriers
  - Coordinate federal government programs to make broadband accessible to lower income residents
  - Outreach to communities (or agencies within those communities) to determine and address needs
- Use of ARPA funds – there are several ways a community might be able to use ARPA funds to improve broadband. Options could include:
  - More in-depth study of broadband details. Examples of deeper studies are:
    - Access need – if there are certain Census block or even streets that the Central Iowa Broadband Internet Study did not have enough survey response, it could be helpful to providers and for grants to gain more data. This could be done through an additional survey, making phone calls, going door to door or emailing (if email addresses are available). This could help a provider know the potential to build that area or could be used to appeal State or federal maps
    - Adoption Need – finding a more detailed understanding of groups and individuals who are not able to adopt broadband (even when it is available) could help with understanding their needs and ways to help them access service
    - Feasibility of options – when there are options that either the community could take or ways that the community could help providers, a detailed understanding of costs and potential revenues (if applicable) can help with decision making
  - Matching grant dollars – if funds can be used to provide grant matching dollars for providers, a system that is fair and equitable and that has impact on the ability to secure the grant could be utilized. Any plan would need to be reviewed by the government agency attorney and evaluated closely to ensure this is the best use of these dollars
  - Deploying a network (or part of a network) – if there are reasons why the community might be the best entity to deploy infrastructure, ARPA funds might be a

source to do that. Any plan should be reviewed by the agency attorney. Possible infrastructure could be conduit, fiber, point-to-point, Wi-Fi, CBRS, etc.

#### DEVELOP A BROADBAND STEERING TEAM

Organizing broadband efforts and keeping broadband initiatives moving forward will require an ongoing commitment. Developing an ongoing Broadband Steering Committee team can help organize and coordinate ongoing broadband related efforts.

This Steering Team can contain several key participants:

- Champion(s) - identifying the champion (or champions) for broadband in the community can provide enthusiasm and, potentially, knowledge
- Members - stakeholders who are leaders of entities that can impact the progress of broadband (government departments, providers, those who have connections with those who might have struggles adopting service, those who can help with specific issues like grants, financing, etc.)

It can be helpful to empower this team with the authority needed to take meaningful action or to ensure there is a clear path to take steps to improve broadband.

Having regular meetings, likely monthly, can also help keep progress moving.

#### POLICY

Public policy and the permitting process can have a significant impact on broadband infrastructure investment. Policy and the permitting process need to match your broadband goals. If some departments want to attract greater broadband investment, but policy and the permitting process discourage new infrastructure, providers might not invest in your communities. See the Appendix that provides a policy sample.

Policies and permitting processes that can encourage broadband:

- Dig Once – this type of policy attempts to provide coordination for conduit to be installed when there is other construction taking place. The goal is to have a process in place to quickly evaluate whether conduit can be added when the ground is torn up for other construction projects. These projects could be when other utilities are being installed, when there is road work being done, when a provider is installing other broadband infrastructure, etc.

The most common scenario is that the county or city pays for the conduit material, but there are many scenarios that can be negotiated.

Dig Once policies center on having a fast moving notification and coordination process that quickly moves through several steps: A construction project is identified (in a CIP plan, a permit is applied for, etc.), the parties are contacted that could be involved (the relevant municipal departments, the entity who is doing the project, the contractor,

etc.), a cost is determined for the conduit, a decision is made as to whether conduit will be added, procurement and installation steps are followed.

It is important to document any infrastructure that is placed. This could be done in GIS or other maps that the county or city keep. Without good documentation, it can be difficult to keep track of where the open conduit is.

- Preferred Path – if there are areas that the county or city wants broadband infrastructure to go to or if there are certain segments of RoW that are congested or have other availability issues, then the county or city can designate certain segments of RoW as preferred paths. The policy and permit processes can designate certain steps that the permittee can take and if the permittee takes those steps, they can get their permit significantly faster and cheaper. Speed to market and less headaches matter to providers.
- Collocation – this is a policy concept that encourages providers to utilize common infrastructure to save RoW space, provide good aesthetics and, hopefully, save money. Collocation works with policies like Dig Once to, then utilize the installed open conduit (or other shareable assets).

These policies can include a notification and collaboration process, what is used to encourage the collocation, and how the collaboration is to be done.

- RoW Management – RoW can become congested. This can happen either because there are enough utilities in the RoW that available space is becoming a concern or there are other impediments like wetlands or deep slopes, etc.

When RoW is becoming congested (or there are concerns that available space will be running out), the county or city can pass policies that define the meaning of congested RoW and outline the alternatives that those who want to use those RoW segments will need to follow to leave as much RoW as possible. Having a way for providers to see those segments and know their alternatives is important for them to be able to plan their routes.

## COLLABORATIONS

There can be several entities that can be good partners to improve broadband. They can provide expertise, networks, possibilities for funding and ways to connect with different stakeholder groups. They could also help you know what middle mile is available or work with you to facilitate middle mile (if that is an impediment to broadband expansion). Examples of these groups can be:

- Libraries – most libraries are already providing connectivity to many people. They work with many people who are struggling with adopting broadband and they may have access to alternative funding sources like e-rate

- Regional groups – there are regional organizations who are interested in improving broadband. These groups can include The Partnership, regional government groups, regional economic development groups and regional broadband groups
- Providers – working with the providers in your area can help communicate plans and opportunities and to know what their plans are.

Ensuring there are regular paths of communication is important.

#### ACCESS STATE TOOLS

- Broadband Strategy Education – the State of Iowa recently contracted with Fiberutilities Group to provide high level broadband education. These services are paid for by the State and can act as a primer to help communities understand the different aspects of broadband and next steps that can be taken.
- “Broadband Ready” and “Remote Work Ready” Certification – in September 2021, the State Economic Development Authority is currently writing the rules for this certification program. The goal appears to be to help communities take the steps to be able to improve broadband at a community level.

#### COMMUNITY PARTNERSHIPS

There are two ways to think about Community Partnerships: Internal and External.

Internal:

Internal potential partners are those stakeholders within the community. They all have broadband needs, and some have broadband infrastructure. These internal stakeholders can help define the needs and, possibly, create solutions. From their needs, they can provide demand for business cases for broadband expansion, and they might be able to provide financial or infrastructure avenues to improve broadband.

- Municipal Departments
  - Public Works – municipal agencies have office connectivity needs, but many in the Public Works or roads realms also have field personnel and dispersed assets. The infrastructure in the field is often not connected or connected by dsl, point-to-point or cellular connections (which can be unreliable and/or expensive)
  - Economic Development – this department can help identify and lead broadband related steps they are aware can help retain businesses and bring businesses to the area
  - Information Technology
  - Emergency Management/Response – many EMS and first responders have multiple paths of connectivity (radio, cellular, etc.); their facilities need good connectivity and their field personnel often have unmet connectivity needs
  - Municipal Administration – management can have an important role in broadband in several ways: leading or coordinating broadband efforts, ensuring municipal facilities have the broadband and redundancy they need, knowing if broadband policies support broadband efforts

- Planning – knowing the upcoming municipal projects can help to coordinate any broadband infrastructure the agencies might be able to put in while the project is in construction
- Permitting – this agency can help broadband efforts by communicating what permitting requirements are for broadband projects (if those help or hinder broadband) and by communicating what broadband related permits have been applied for
- Anchor Institutions
  - Libraries – they are already providing access to broadband for some members of the community
  - Medical facilities – they have needs for their operations and for their patients (to communicate and for telemedicine)
  - Education – they have needs for their operations and for their students to complete their assignments (and learn remotely when necessary)
  - Social Services (these organizations might be able to help reach those who either do not have access to broadband or have access but have difficulties adopting)
- Businesses
  - Key employers
  - Agricultural
  - Greater broadband users
  - Real estate
- Financing institutions
- Providers

## External

There are several stakeholders external to your county or city who can be helpful in improving broadband. Working with them to see where collaboration would make sense can be important in being able to take broadband steps.

- The Partnership – broadband is an important issue for The Partnership. The Partnership will continue to look for ways to facilitate collaboration to improve broadband in the 11-counties
- The State of Iowa
  - Grants – the State has expressed a commitment to continue to provide grants for broadband. In September 2021, the State provided \$100 million for broadband grants in NOFA #6 and is expected to provide more grants
  - Broadband Education/Consulting – in August 2021, the State announced a broadband primer program through Fiberutilities Group. This is meant to help communities better understand the steps needed to improve broadband. This guidance is paid for by the State
  - Regional – regional collaboration is important for several reasons
    - Middle mile – sometimes having access to get to the internet (or phone or video) can be cost prohibitive. Regional collaborations might be able to identify access or even build middle mile to make this more affordable (and pay for itself)
    - Coordination – knowing who and what broadband resources are around a community can be very important in helping to know what broadband options are available
    - Cost reduction – regional collaborations can sometimes realize an economy of scale to reduce costs
- Broadband Organizations – there are groups already in place for advocacy and education on broadband (regional and national) that are excellent resources for communities

- Consultants – many functions of broadband improvement are provided by consultants (survey, feasibility, design, construction oversight, operations, and maintenance)

## Provider Recommended Practices

The Central Iowa Broadband Internet Study initiated a process and steps to improve broadband in Central Iowa that can also be beneficial for providers in the study area. The Study provided:

- Information that can be used in network planning and grants
- Lay-out on provider needs for grant preparation
- Beginning discussions on how funds like ARPA money can be used in broadband projects
- An introductory collaboration on policy
- Meetings with other providers and municipal leaders
- An early discussion on the needs that providers have for financing options

These were all important steps in beginning collaborations that can help improve broadband in Central Iowa and provide win/wins for the stakeholders in the area (including providers).

The Study showed that there are broadband needs in Central Iowa. The State of Iowa broadband maps showed the following needs. The columns that show the parcels for each grant tier highlight the number of people who are unserved or underserved in Iowa. When the costs to reach those parcels are calculated, there is an approximate cost of \$769 million in projects to expand broadband (these represent just the identified needs).

County	Cost Per Parcel	Tier 1 Parcels	Tier 1 Cost Per County	Tier 2 Parcels	Tier 2 Cost Per County	Tier 3 Parcels	Tier 3 Cost Per County	Total Costs Per County
Adair	15,028.00	870	13,074,360	1699	25,532,572	741	11,135,748	49,742,680
Poweshiek	14,159.62	181	2,562,891	3362	47,604,642	1471	20,828,801	70,996,335
Story	12,237.50	1271	15,553,863	2399	29,357,763	961	11,760,238	56,671,863
Dallas	11,244.34	270	3,035,972	800	8,995,472	102	1,146,923	13,178,366
Warren	11,218.56	333	3,735,780	5171	58,011,174	397	4,453,768	66,200,723
Madison	12,785.04	491	6,277,455	453	5,791,623	49	626,467	12,695,545
Marion	12,785.04	171	2,186,242	6264	80,085,491	537	6,865,566	89,137,299
Polk	12,785.04	1144	14,626,086	2903	37,114,971	2591	33,126,039	84,867,096
Marshall	12,785.04	718	9,179,659	7653	97,843,911	87	1,112,298	108,135,868
Jasper	12,785.04	629	8,041,790	7155	91,476,961	2817	36,015,458	135,534,209
Guthrie	12,785.04	492	6,290,240	452	5,778,838	5479	70,049,234	82,118,312
			<b>\$84,564,337</b>		<b>\$487,593,418</b>		<b>\$197,120,540</b>	<b>\$769,278,295</b>

Building on the introductory steps to improve broadband mentioned above, the following practices are recommended for providers:

GRANTS – as is discussed in the Final Report, there are several grant opportunities that represent a once in a lifetime possibility to receive grant dollars for broadband projects. The State of Iowa and the federal government are showing a strong commitment to funding broadband expansion. The time is now to work together to receive grant money in Central Iowa. The following steps are recommended:

- Knowing the needs – the Study provided good information with over 4,000 people taking the survey. This information can help plan network extensions. In some cases, the data provides clear information and in other cases it could be beneficial to do some follow up research (canvassing, mail, email, etc.).
- Grant writing support – there is a lot of grant money available and coming available, but these are competitive grants. Continuing the collaboration between providers, communities, and consultants to produce the best grant applications possible could help to increase the funding percentage for Central Iowa. In NOFA #6, Central Iowa did receive some funding (\$7.4 million – detailed in the Provider Engagement section of this report), by working together, that number should be able to be increased.
- Appeals – the information from the Study pointed out several areas in which the speed tests were inadequate, but the State Broadband Map showed ineligible. The federal maps have, typically, had even more areas that are inaccurately shown as not eligible for grants (the coverage is shown as better than it actually is). These areas can be appealed - either within a grant window if that is the grant agency process or at any time. That will take a coordinated and collaborative effort that could be done now.

COLLABORATION – there have been several steps that have been initiated to foster collaboration to improve broadband in Central Iowa. This should be a benefit to the region and to the providers if they are continued. Collaboration could center on:

- Grants – as discussed above.
- Regional solutions – there should be opportunities to reduce costs by looking at broadband improvement from a regional basis. Solutions could include shared infrastructure, policy changes, middle mile, grants, multiple stakeholders who help projects, etc. There are stakeholders who could offer resources to lower the costs of projects. Examples of these could be:
  - Counties
  - Cities
  - Regional organizations (government, economic development, adoption related, etc.)
  - Iowa Department of Transportation
  - Business who needs better broadband
  - Railroads (they often have communications infrastructure and excess capacity)
- Middle Mile – this is an important topic that needs further collaboration, particularly as projects are being considered. If the cost to reach rural and remote customers is drastically high, there could be Middle Mile solutions that could lower costs and pay for themselves. This could especially be the case if certain stakeholders have needs that could be met in conjunction with broadband improvement projects.



- Policy – as our provider policy meeting showed, there can be a disconnect between policy makers and providers that can unnecessarily make broadband improvement more costly and take longer. Collaboration can improve this by helping both sides form a better understanding of what each side needs.
- Adoption – the Study showed that there are significant numbers of people who have access to good broadband, who are not taking the service (see the Survey section of the final report). It will take collaboration of agencies who work with these groups, communities and providers to help these stakeholders adopt service. Doing that will help these populations receive the benefits of good broadband and will help pay for the infrastructure.

FINANCING – as the previous chart shows, improving broadband in Central Iowa will cost a lot of money. Grants can help with those costs, but there are other sources of financing. Please see the Recommended Practices for Financing Entities in this Appendix for ideas on collaboration to help pay for these infrastructure deployments.

TECHNOLOGY PLANS – in this final report, each County has a specific technology plan that shows the costs for fiber (where appropriate for costs) and other technologies. These provide a detail of routes and costs. They can provide a basis for grant applications and preliminary plans for broadband improvement options.

DASHBOARD – as part of the Central Iowa Broadband Internet Study, there is also a dashboard that shows needs and projects along with other Central Iowa broadband information. Referring to the dashboard for updated broadband information and opportunities will help coordinate future steps. The dashboard can help with:

- Coordinating routes (to share costs and lower duplication costs)
- Technology options
- Grant opportunities
- Access to information
- Other opportunities

## Financing Entities Recommended Practices

This set of Recommended Practices is provided for the entities who might be interested in providing some form of financing for broadband projects in the Central Iowa Study area.

Broadband is critical infrastructure for economic development, working from home, education, telemedicine, ability for seniors to stay in their homes, keeping youth in a community and many other quality of life applications. The COVID-19 pandemic showed the degree to which connectivity has become a necessity in many aspects of our lives. Additionally, the level of importance of good broadband has also made clear the challenges faced by those who do not have access (broadband infrastructure being available) or have struggles with adoption (choosing to become a customer when it is available).

As the study showed, there are broadband access and adoption challenges in the Central Iowa Broadband Internet Study area. With the goal of improving both broadband access and adoption, there is an opportunity for entities to provide the funding for these projects.

The chart below shows the need that has been identified by the State of Iowa OCIO in their Map # 4. Tiers 1 – 3 are all eligible for some grant funding. The total high-level costs for projects to meet all of the identified needs is \$769,278,295.

County	Cost Per Parcel	Tier 1 Parcels	Tier 1 Cost Per County	Tier 2 Parcels	Tier 2 Cost Per County	Tier 3 Parcels	Tier 3 Cost Per County	Total Costs Per County
Adair	15,028.00	870	13,074,360	1699	25,532,572	741	11,135,748	49,742,680
Poweshiek	14,159.62	181	2,562,891	3362	47,604,642	1471	20,828,801	70,996,335
Story	12,237.50	1271	15,553,863	2399	29,357,763	961	11,760,238	56,671,863
Dallas	11,244.34	270	3,035,972	800	8,995,472	102	1,146,923	13,178,366
Warren	11,218.56	333	3,735,780	5171	58,011,174	397	4,453,768	66,200,723
Madison	12,785.04	491	6,277,455	453	5,791,623	49	626,467	12,695,545
Marion	12,785.04	171	2,186,242	6264	80,085,491	537	6,865,566	89,137,299
Polk	12,785.04	1144	14,626,086	2903	37,114,971	2591	33,126,039	84,867,096
Marshall	12,785.04	718	9,179,659	7653	97,843,911	87	1,112,298	108,135,868
Jasper	12,785.04	629	8,041,790	7155	91,476,961	2817	36,015,458	135,534,209
Guthrie	12,785.04	492	6,290,240	452	5,778,838	5479	70,049,234	82,118,312
			<b>\$84,564,337</b>		<b>\$487,593,418</b>		<b>\$197,120,540</b>	<b>\$769,278,295</b>

In NOFA #6, the State provided \$100 million. In NOFA #7, the State offered \$200 million. Those are big numbers, but they leave \$450 million still to be paid for.

Those numbers do not include needs that exist that are not identified in the OCIO maps or the possibilities of what increased adoption can add to the needs and revenue streams.

According to Investopedia, the average profit margin of telecommunications companies is 17% (<https://www.investopedia.com/ask/answers/060215/what-average-profit-margin-company-telecommunications-sector.asp>). Telecommunications networks are considered a good investment by many financing institutions because they are a capital asset and have proven ways of determining need and expected take rates.

There are several financing options that are considered in the Recommended Practices for financing entities.

#### DETERMINE FEASIBILITY

- Survey - The Central Iowa Broadband Internet Study included a survey that included locations of homes and businesses, their current internet speed and their level of satisfaction with their current service
- Dashboard – The Partnership provides a dashboard that shows the current needs and planned grant funding options
- Revenue – From the survey results, an expected take rate can be determined, which determines expected revenue
- Costs – There are several ways to determine costs:
  - The costs listed in the chart above are based on a fiber cost per parcel that fairly closely aligned with the grant application requests in NOFA #6
  - The Technology Plans in the beginning of this report show a mix of technologies for each county, based on what is most feasible costs of deployment. The costs derived in these options can be used to gain a high-level understanding of the costs for projects in each county.
  - This mix of technologies include:
    - Bored fiber
    - Trenched fiber
    - Arial fiber
    - Wireless point-to-point
  - CapEx and OpEx can be determined

With these numbers, feasibility can be determined, which can show how much money is needed to be borrowed, what payback timelines can be expected, and when profitability will be reached.

#### GRANTS

There are several sources of grants available (see the Grants section in the Executive Summary). Most of these are focused on unserved and underserved citizens and businesses. There can be other grants that are based on promoting specific interests, such as energy efficiency, main

streets in downtowns, smart community, job creation, etc. that can often be used for broadband.

These grants can help lower the cost of deployment, which can make the difference in whether a broadband project is feasible. This is especially the case in rural and remote areas in which the cost of deployment is dramatically high, especially compared to the amount of revenue that can be generated in sparse population areas.

Options for financing these projects include:

- Public debt issuance
  - Municipal-owned conduit in Rights of Way; leased to providers
  - Tax Increment Financing economic development grants in blighted districts
  - Voted municipal utility formation within incorporated areas; issue revenue debt
  - Change in public pooled debt options; Iowa Finance Authority model whereby IFA collateralizes the broadband asset and 1<sup>st</sup> claim to revenues (see white paper in Appendix E)
- Private debt issuance
  - Financing institutions provide the capital, backed by the infrastructure, based on the feasibility study, operational skills of the entity and the creditworthiness of the entity
  - Provider loan guarantee program from public sources that supplement grants (that serve as equity); both for network extensions and middle mile connections
  - Conduit Real Estate Investment Trust sponsorship by regional capital & retirement plan providers where smaller providers can access larger funding sources at more favorable terms
- Consumer-owned or crowdfund
  - Central processor/portal for voluntary assessment by property owners financed by a public source or local financial institution
  - Unsecured crowdsourcing whereby those with investable funds finance connection fees/drops for those without the funds under a standard non-collateralized platform
  - Collaborative effort by private citizens and/or businesses and organizations to pay for all or part of a broadband extension
  - Cooperative formation to organize a build effort, finance all or part of the build and arrange financing where necessary
- Public-Private Partnership debt and equity issuance
  - Loan guarantees provided to participants and providers supporting broader regional digital inclusion goals (connections + adoption + digital literacy)
  - Non-Profit Foundation formation to achieve long-term goals through public and private support

## MIDDLE MILE FIBER

One other important consideration in improving broadband is the middle mile connection. Individual networks have to make a connection to the world outside of their network. These are available in some places, may not be available in others or they might be somewhat close, but still need a connection to them.

When middle mile is not particularly close, the cost to make this connection can be enough to make a marginally feasible project no longer feasible.

This can also provide an opportunity. If middle mile can be shared and added as a shared leased cost to a project, it can help a project be feasible and can also be a source of revenue for itself. All interested parties (government, providers and financing entities) can collaborate to find a path that can share the costs and thus share the revenue from the connecting networks.

## Consumer Adoption Advocacy Recommended Practices

There are two sides of broadband availability: Access and Adoption. Access refers to broadband being available to customers. Adoption describes whether customers choose to utilize broadband when it is available. This Recommended Practices section discusses Adoption (when people have broadband available but choose not to utilize it).

As the Central Iowa Broadband Internet Study showed, there are large numbers of people who have access to broadband but are not utilizing it. In the survey section of the final report, the following observation was made about those not adopting available service:

*Among the non-adopters by choice, the primary reason they don't subscribe is that available services are too expensive. Non-adopters in cities appear to be more price sensitive to those in rural areas. While 62% of rural residents are willing to pay \$61 or more per month for internet if it were available, only 36% of town/city residents said the same. Other respondents reported that available internet was too slow to justify a subscription or were too unreliable. Only a small percentage of non-adopters reported that they didn't have a suitable device to connect to the internet or were concerned about privacy.*

This is an important issue because within those who choose not to adopt, there are often people who would like to, but have some barrier.

Now we will discuss Recommended Practices to help those who would like to adopt available broadband but who are facing a barrier that might be able to be overcome. Examples of these barriers could be affordability, language barriers, age, technology issues, etc. These all point to people who would likely be able to benefit from good broadband and who often can be helped to access available broadband. Hurdling the barriers:

- Establish a regional digital inclusion task force – the coordination of information and efforts around digital inclusion will take leadership. Developing a task force to set goals, enact specific steps, maintain momentum, and monitor progress could help guide adoption improvements.
- Collaboration with appropriate agencies – there are excellent resources in the Central Iowa Broadband Internet Study area who work with populations who have difficulties in adopting available broadband. A coordinated effort could have significant adoption impacts. Suggestions:
  - Develop a list of agencies to be involved in broadband adoption (those who work with lower income constituents, those involved in language specific populations, agencies who work with seniors, etc.)
  - Involve libraries – most deal with broadband related issues on a regular basis
  - Coordinate ongoing adoption focused strategy meetings of the above groups
  - Determine if there are ways counties or cities could use funds to improve affordability or connection with broadband non-adopters

- Provide low-cost options – many providers have low-cost options. In working with providers, this could be discussed, and any low-cost options could be made known with the collaborating agencies.
- State or federal resources – there are programs to help improve cost related adoption. One example is the FCC’s Lifeline program, which provides a monthly discount for low-income households. The City of West Des Moines produced a portal to help connect those who are having difficulty with the cost of broadband with the Lifeline Program. Perhaps other counties or cities within the 11-county study area could either collaborate with West Des Moines or emulate the portal.
- Cataloguing and mapping internet sources – the Colorado Broadband office has catalogued options for free or discounted broadband, including public Wi-Fi, schools, libraries, etc. This type of effort could help people know where they can get free broadband, if they can access the resource, and if those with free broadband have the broadband capacity to participate.

## Appendix A - Glossary of Terms

**Access** – infrastructure that delivers broadband – if there is infrastructure available to a potential customer (through any technology), that potential customer has access

**Access Point** – a device that allows wireless devices to communicate with a wired network using Wi-Fi or related standards. Sometimes referred to as AP, Wireless Access Point, or WAP. Access Points contain both a radio and a wired network connection, and relay communications between the two.

**Adoption** – customer decision to purchase broadband services that are available

**Backhaul** – is the fiber that carries aggregated user data from the network’s central office to internet connection points located at carrier hotels.

**Backbone/network backbone** – in telecommunications, a generic term referring to the part of a network that interconnects all sites on the network, and, therefore, handles the majority of the network traffic. Smaller networks are attached to the backbone through aggregation sites by means of additional circuits and network devices, such as routers.

**Bandwidth/high bandwidth** – transmission capacity of an electronic pathway such as a communications circuit. Network bandwidth is described in terms of how much data can move across the network within a given amount of time and is typically expressed in bits per second (bps). Examples of measurements include kbps, Mbps or Gbps. The “high” in “high bandwidth” is always relative to current norms for different circumstances. High Bandwidth is a term that typically means a bandwidth at the top end or above what is commercially available at a given location.

**Broadband** – a marketing term that refers to high bandwidth internet access. Traditionally, it meant “any band- width greater than dial up.” Broadband data transmission is digital, meaning that text, images, and sound are all transmitted as “bits” of data. In the context of this project, broadband refers to providing internet connectivity at much higher bandwidth than has been available and affordable to most libraries. The FCC, in 2015, defines broadband to the home to be anything above 25 Mbps, in the sense that anything less than 25 Mbps to the home would not qualify as “broadband.”

**Capacity/high capacity** – is the complex measurement of the maximum amount of data that may be transferred between network locations over a network, also known as throughput. “High” is again relative to current norms and measured in bits per second (bps).

**CBRS** – Citizens Broadband Radio Service – a wireless network capable of 4G and 5G connectivity that can be segmented to carry different applications (internet, Public Works related applications, public safety communications, etc.)

**Co-location** – refers to the way information technology hardware and resources are located or installed in a shared or common location. In this context, networking hardware resources



owned by an organization are located outside the organization's physical premises and "co-located" with other organizations' hardware, often through a commercial service provider.

**Commercial networks/carriers (providers)** – any entity engaged in the business of providing telecommunications services that are regulated by the Federal Communications Commission or other governmental body. These are generally for-profit companies.

**Dark Fiber** – installed fiber not currently being used.

**Digital Subscriber Line (DSL)** – a family of technologies that are used to provide internet access by transmitting digital data over telephone lines. It may be either symmetric (same bandwidth both direction), or asymmetric (different bandwidth each direction). The service may be implemented simultaneously over the same lines used to provide voice service.

**Federal Communications Commission (FCC)** – the federal agency responsible for regulating interstate communications by radio, television, wire, satellite, and cable. The FCC also participates in international communications standards coordination and policy development.

**Fiber/fiber-optic cable** – fiber optic technology converts electrical signals carrying data to light and transmits the light through transparent glass fibers. A variety of fiber optic cable types are available, depending on the application. Supported distances vary based on cable type, transmitter source (laser or LED), data rate, etc.

**Internet Service Provider (ISP)** – a communications carrier that provides access to the internet. ISPs are not necessarily directly connected via an internet exchange; they may in turn acquire connectivity from another ISP.

**Last mile connection** – a term used by the telecommunications industry to refer to the final leg of a network to the customer, generally from the provider's last POP to the customer.

**Local Area Network (LAN)** – a computer network that interconnects computers within a limited area such as a building or small group of adjacent buildings.

**Long Term Evolution (LTE)** – in telecommunication, a standard for wireless communication of high-speed data for mobile phones and data terminals.

**Megabits per second** – see "Bandwidth" and "Throughput"

**Middle mile** – the segment of a telecommunications network linking a network operator's core network/back-bone to the local provider's network, typically situated in the incumbent telephone company's central office that provides access to the local loop.

**Node** – connection point that can receive, create, store, or send data along a network

**Overbuild** – to create a network that goes into competition with incumbent provider.

**Point-to-Point** – a microwave broadband application that requires line-of-sight from a transmission point to an end point. This technology is less expensive to install and can provide good service (depending on equipment and usage)

**Population Density** – population density will be classified as either urban, rural or remote. For the definition of eligibility for their grants and loans, Rural Utility Services defines rural in two ways: any area not within a city or town with population exceeding 20,000 or an urbanized area adjacent to a city greater than 50,000 and any area not within boundaries of any city, village, or borough with population exceeding 5,000. For this analysis, “rural” will mean either unincorporated or in a community less than 5,000. Remote will mean population density less than one person per twenty acres.

**Right of Way** – the land set aside for public passage or use (street, sidewalk, trail, utilities, etc.) which is owned or controlled by a governmental entity.

**Throughput** – rate of data transmission per unit time; see “Capacity/High Capacity”. The most common throughput measurements include:

- **Kilobits per second (Kbps)** – a transmission rate; 1,000 bits per second. 1,000 kbps = 1 Mbps. Kilo is the unit prefix for 10<sup>3</sup>.
- **Megabits per second (Mbps)** – a data transmission rate; 1,000,000 bits per second. 1,000 Mbps = 1 Gbps. Mega is the unit prefix for 10<sup>6</sup>.
- **Gigabits per second (Gbps)** – a data transmission rate; 1,000,000,000 bits per second. 1 Gbps = 1,000 Mbps or 1,000,000 kbps. Giga is the unit prefix for 10<sup>9</sup>.

**Wired or wireless infrastructure** – wired infrastructure is infrastructure that has a physical wire or line run to the premise (fiber, cable or DSL). Wireless include the technologies that do not have a physical line (point-to-point, radio frequency, etc.)

**Wi-Fi (Wireless Fidelity)** – a local area wireless technology that allows an electronic device to participate in computer network using specific wireless frequencies and protocols. Current standards use the 2.4 GHz and 5 GHz unlicensed industrial, scientific, and medical radio bands. Sometimes referred to as Wireless LAN or WLAN.

## Appendix B – Colocation Policy

### Colocation of County (or City) Infrastructure with Permit Holder's Infrastructure

a. The County recognizes that it is within its police power to preserve the physical integrity of its streets and highways, control the orderly flow of vehicles and pedestrians, and efficiently manage the gas, electric, water, cable, broadband, telephone, and other facilities that crisscross its streets and public rights-of-way. It is the County's policy to efficiently use public rights-of-way for a variety of infrastructure and utilities in order to provide public services; advance the County's goal of increasing opportunities for access to traffic control, communication, and broadband services; limit the frequency of street closures and cutting of public streets; and reduce road degradation caused by repeated boring and trenching of public rights-of-way. To this end, the County requires all Permit Holders proposing Construction Activities that involve directional boring or open trenching within a public right-of-way that extend for more than 1000 feet in length to collocate and install County conduit simultaneously with the permit Holder's Construction Activity. The County shall not be restricted in its use of County conduit installed through a collocation pursuant to this Section 4.2.1. The County will review all permit applications in a competitively neutral manner and make all permit decisions based on substantial evidence. The County may, upon initial review of the permit application, determine that the Permit Holder's proposed Construction Activity does not demonstrate a need for collocation of County infrastructure.

b. For any Construction Activity that requires collocation of County conduit, the County shall, as a condition of the issuance of the Permit or continued validity of a Permit, require the Entity/Permit Holder to install County conduit with tracer wire and associated infrastructure, as identified by the County, concurrent with the installation of the Permit Holder's infrastructure. The requirement for the Entity/Permit Holder to install County conduit with tracer wire and the associated infrastructure shall be completed after the County has reviewed and approved all estimated costs associated with the co-location of the County conduit.

The Permit Holder shall install the County conduit with tracer wire adjacent to the Permit Holder's infrastructure and within the same bore or trench alignment.

The County will bear all costs associated with the collocation, including the County conduit, pull boxes, and all other materials and infrastructure to be installed, including the incremental labor and equipment cost incurred by the Permit Holder (or its contractor or subcontractor) that are reasonably and directly attributable to the required collocation of County conduit, materials and infrastructure.

Pursuant to Section 3.12 of these Regulations, a completion inspection with the Designated Representative is required. When a collocation of County conduit is required, this completion inspection shall include physical verification of the installed County conduit. Upon the County's request, the Permit Holder shall submit to the County signed as-built documentation of the County's conduit and provide the County with a County-approved bill-of-sale or similar document evidencing County conduit ownership following the collocation. The as-built documentation should also be delivered in the form of 3D GIS data, to within a few inches' accuracy, that can be imported into the County's GIS system.

The Designated Representative may waive Permit fees set forth in the Fee Schedule for any Construction Activities associated with a County collocation project. All applicable pavement restoration fees, as set forth in the Fee Schedule, shall apply unless and until a written waiver is

obtained from the Designated Representative. A Permit Holder may appeal a colocation condition imposed by the County in accordance with the appeals procedure set forth in Section 7.0 of these Regulations.

# Appendix C – County Speed and Satisfaction Maps

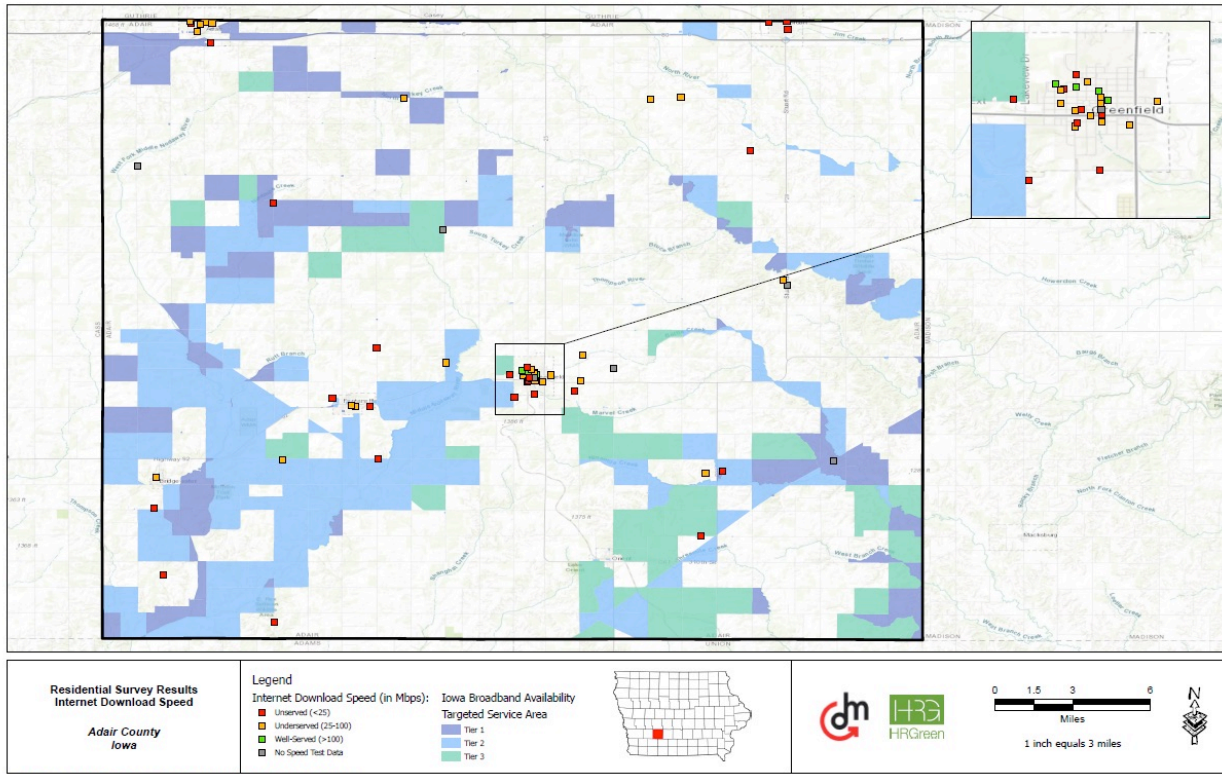

Figure 8 - Speed Test Results in Adair County

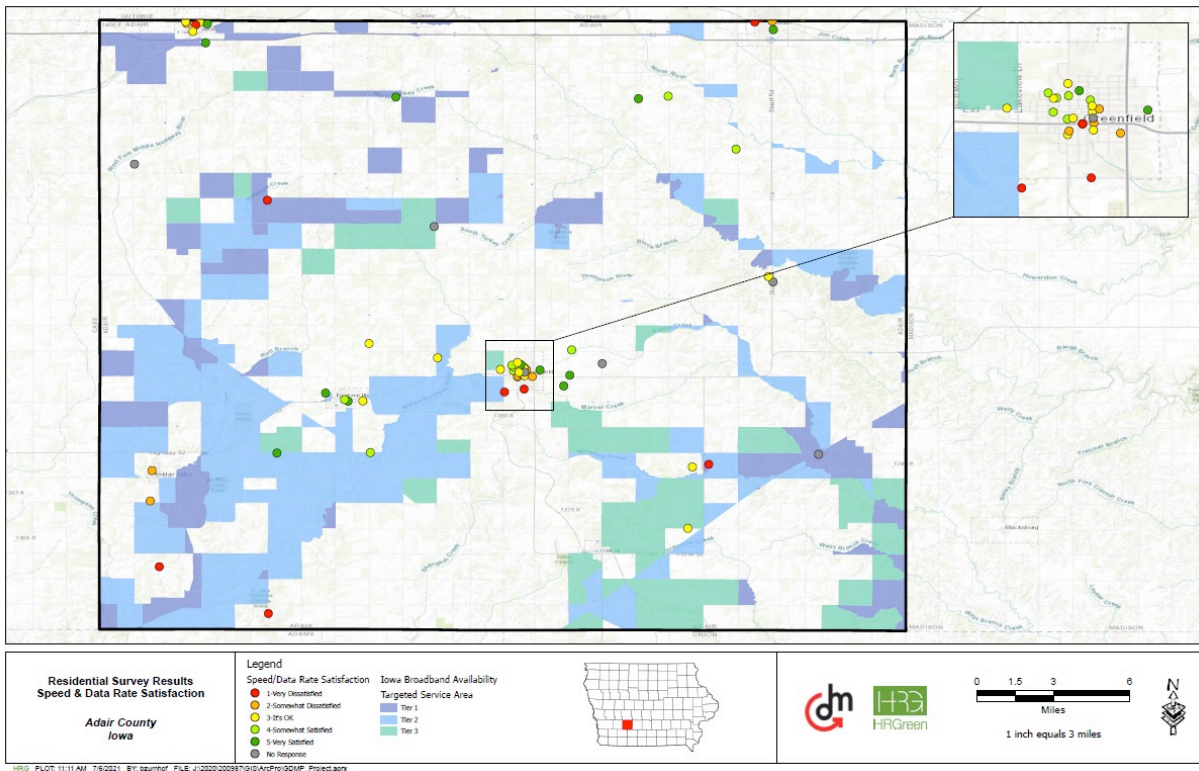

Figure 9 - Internet Satisfaction in Adair County

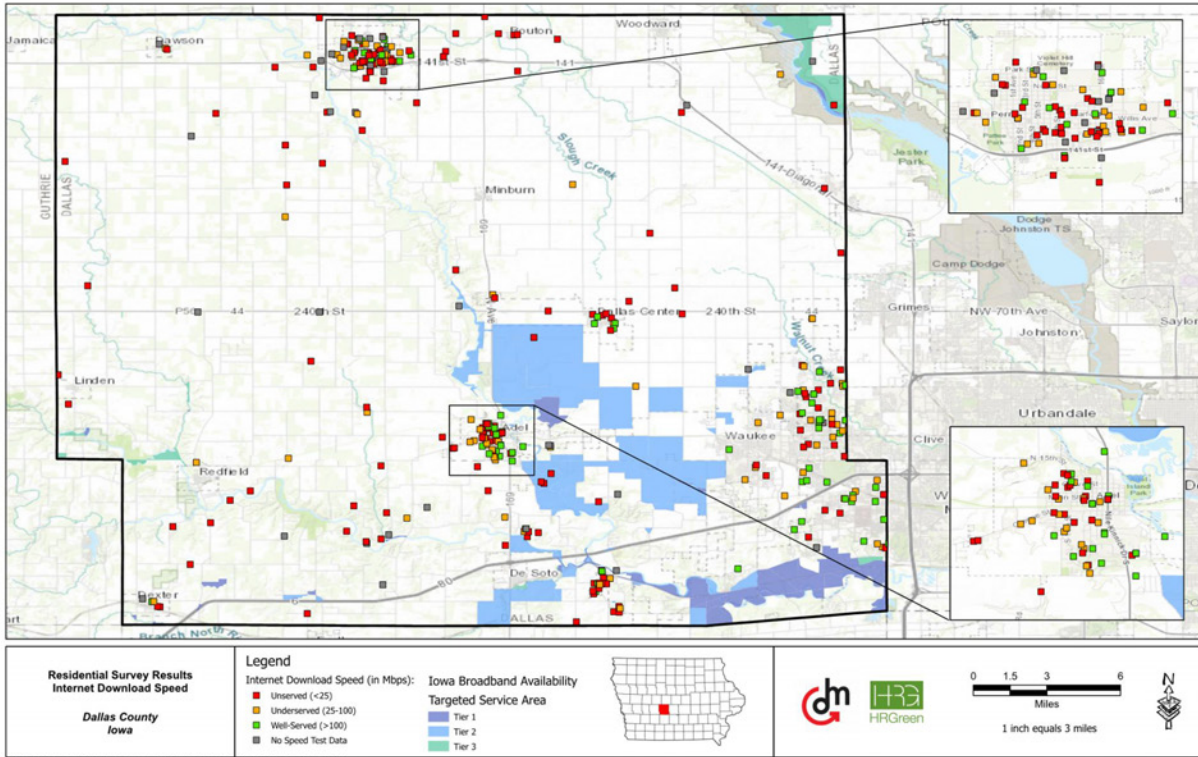

Figure 21 - Speed Test Results in Dallas County

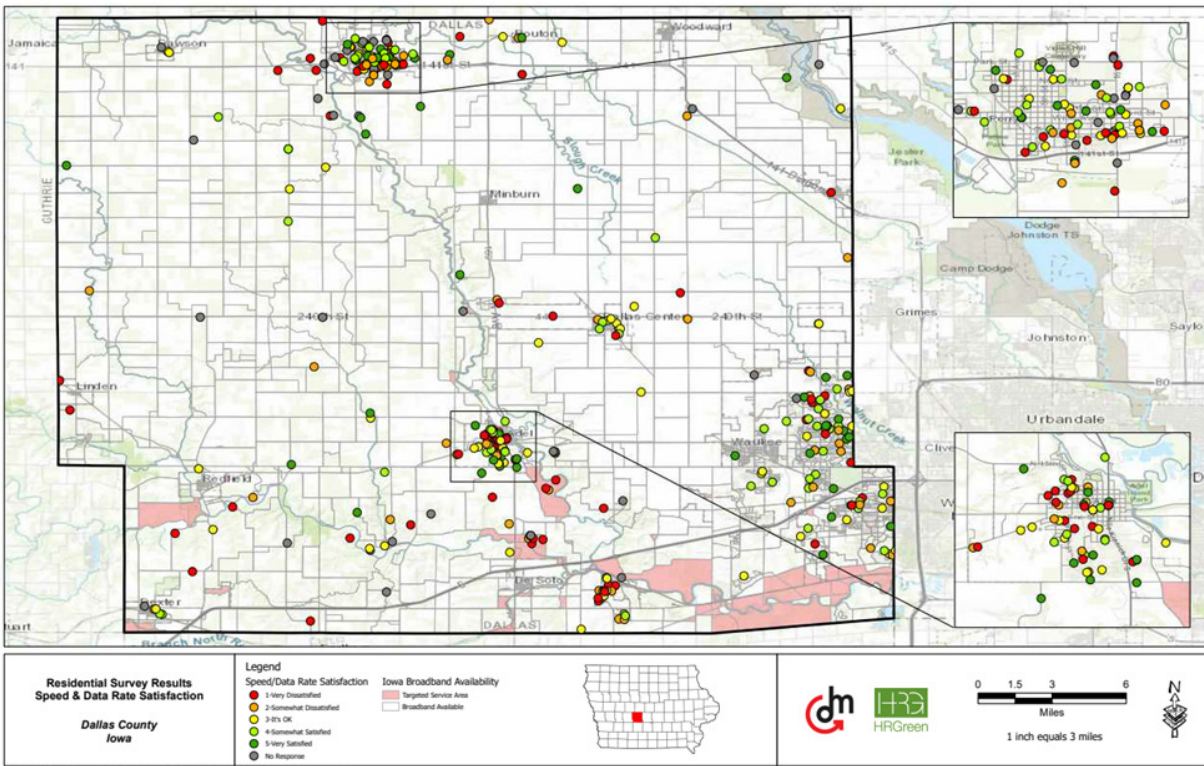

Figure 22 - Internet Satisfaction in Dallas County

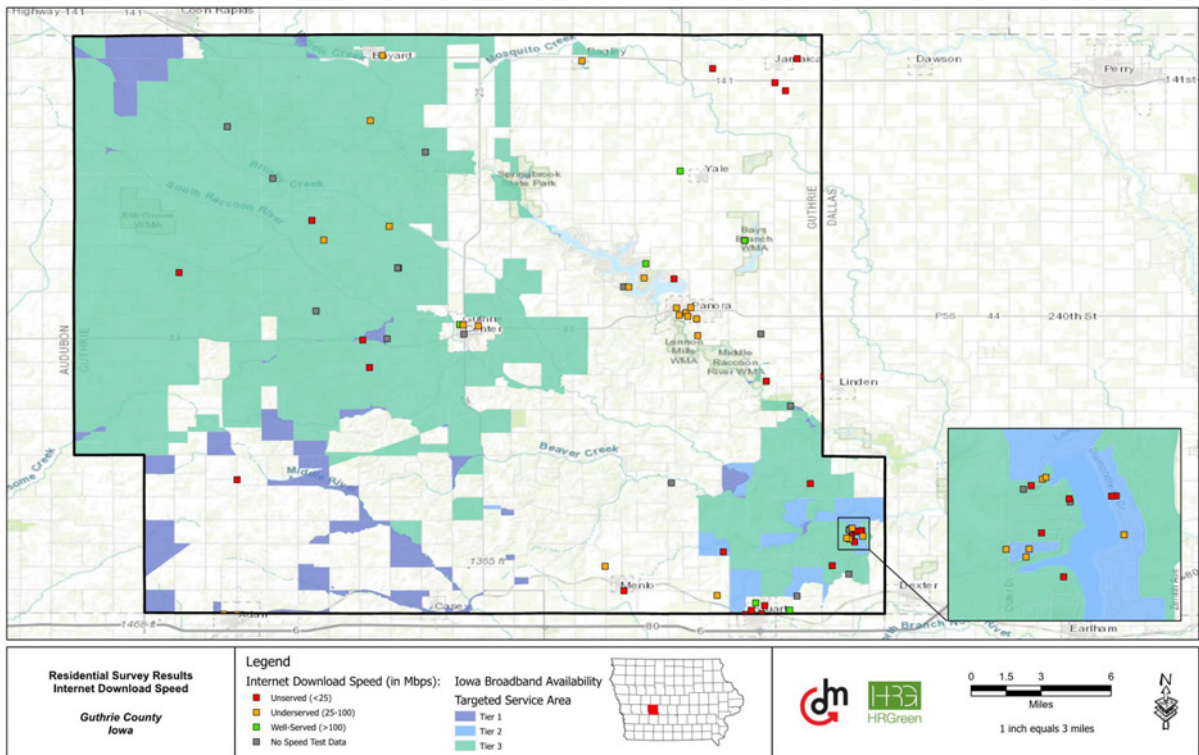

Figure 23 - Speed Test Results in Guthrie County

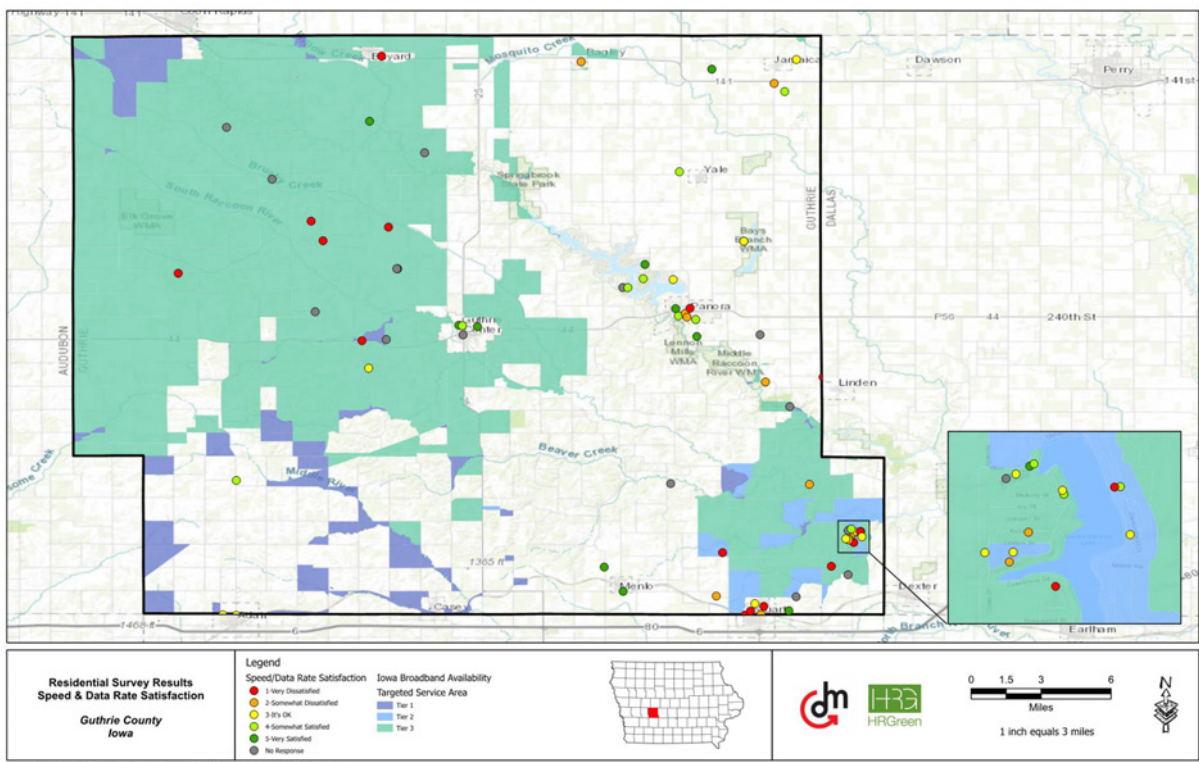

Figure 24 - Internet Satisfaction in Guthrie County

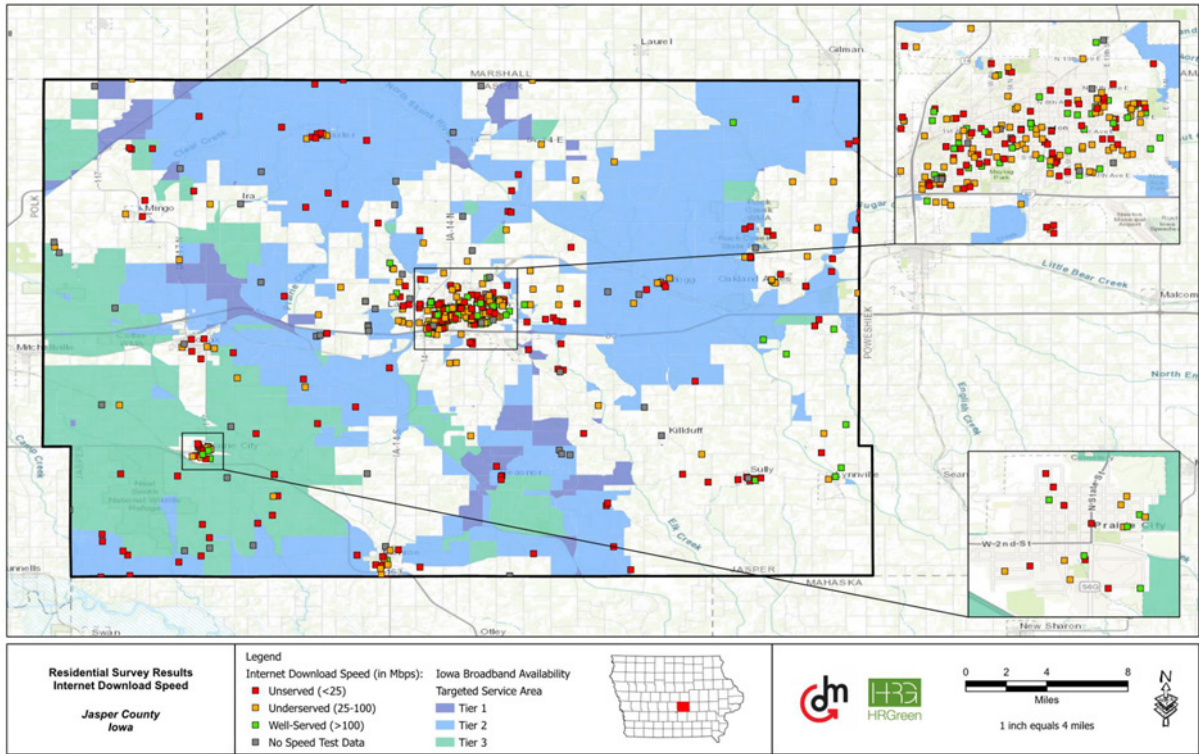

Figure 25 - Speed Test Results in Jasper County

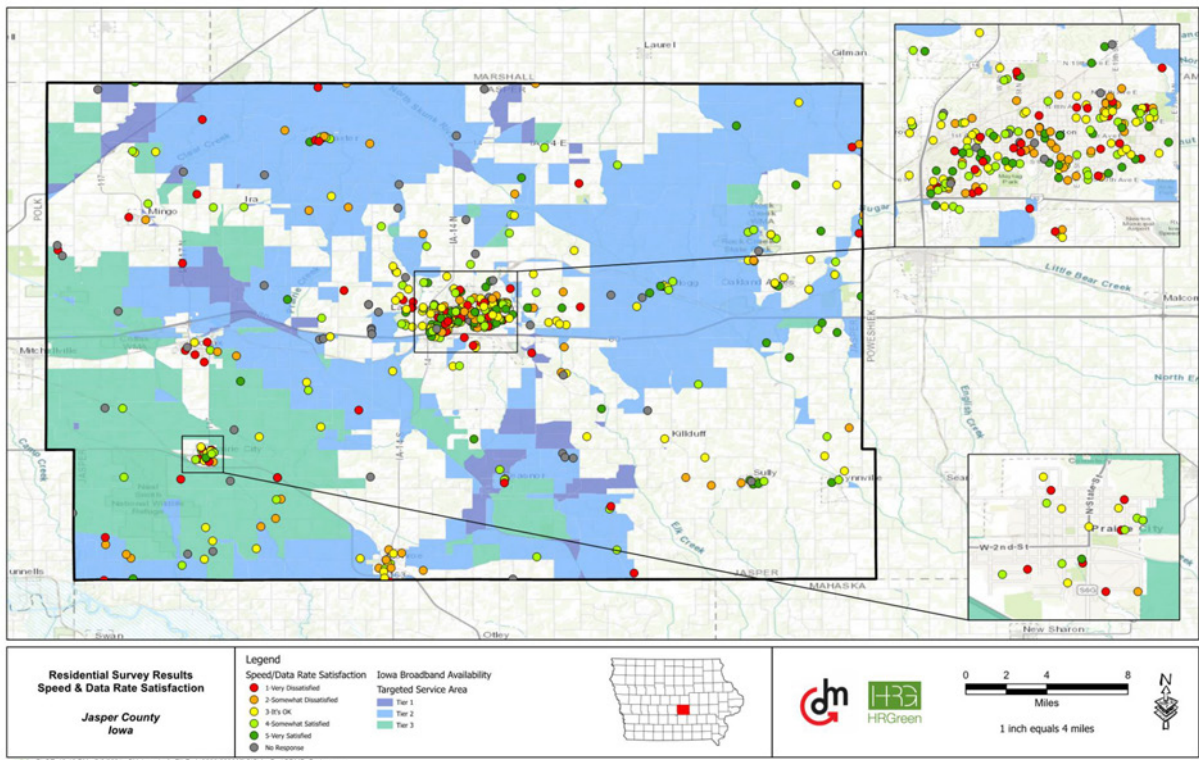

Figure 26 - Internet Satisfaction in Jasper County



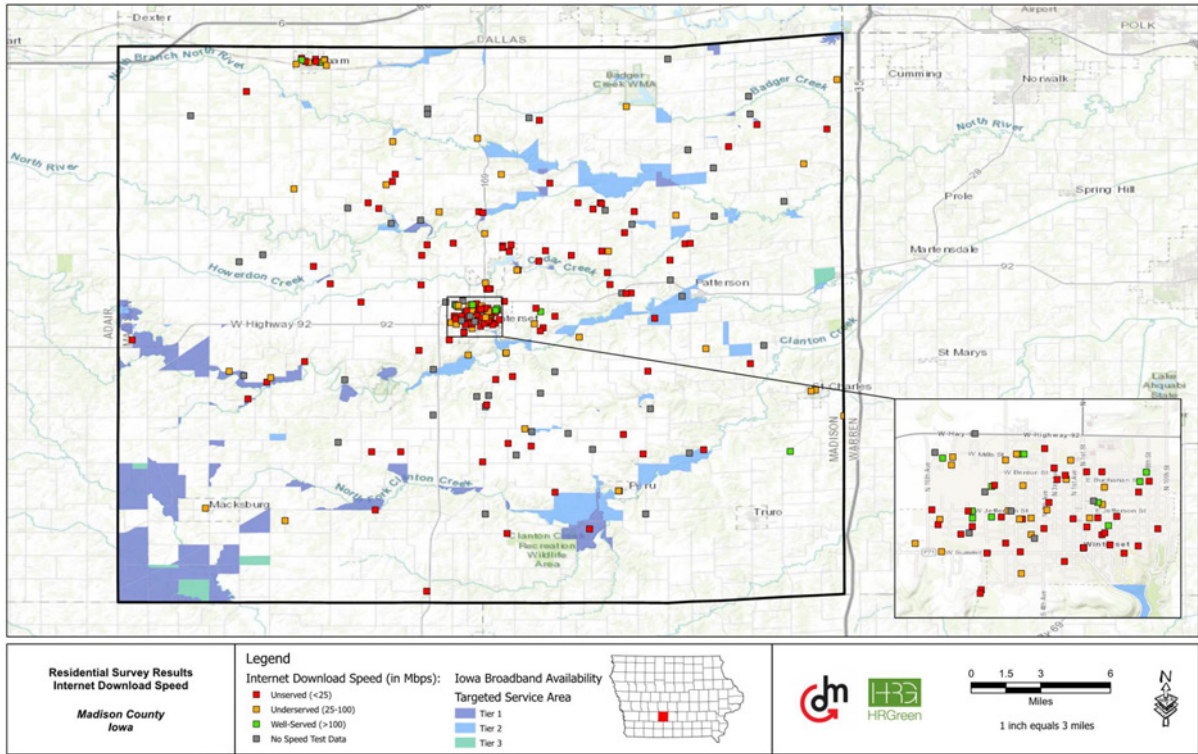

Figure 27 - Speed Test Results in Madison County

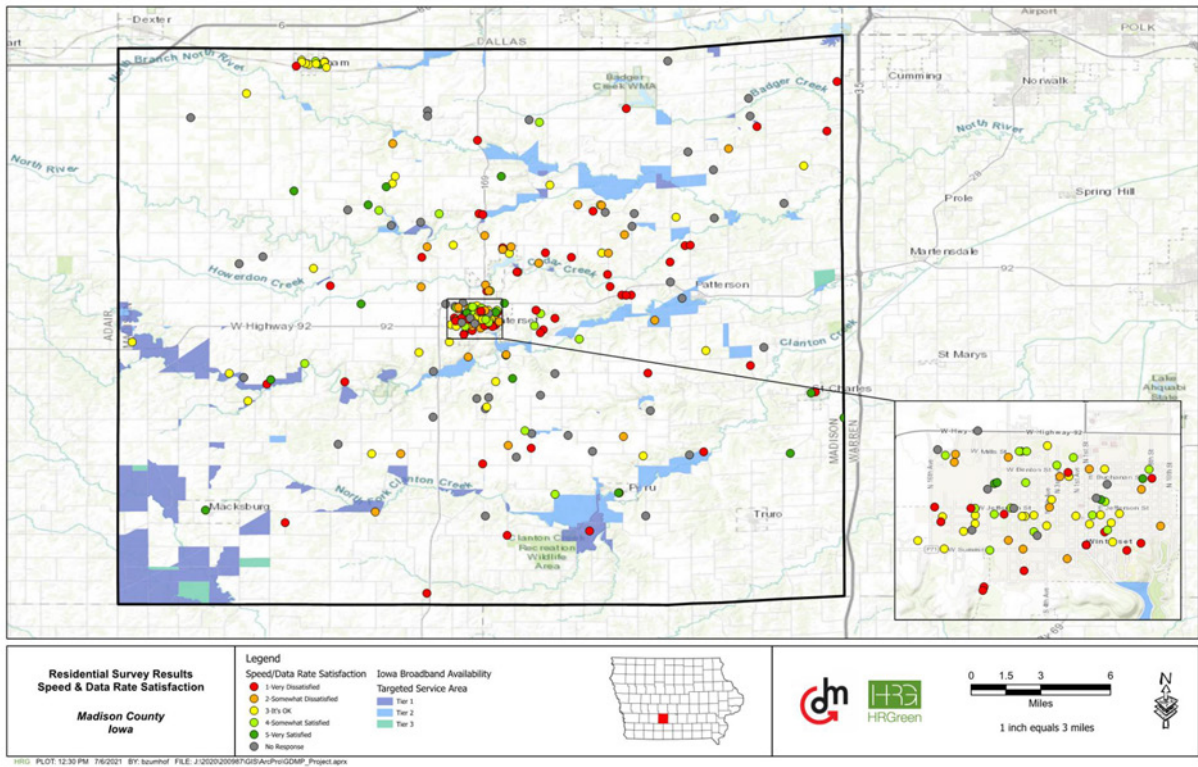

Figure 28 - Internet Satisfaction in Madison County

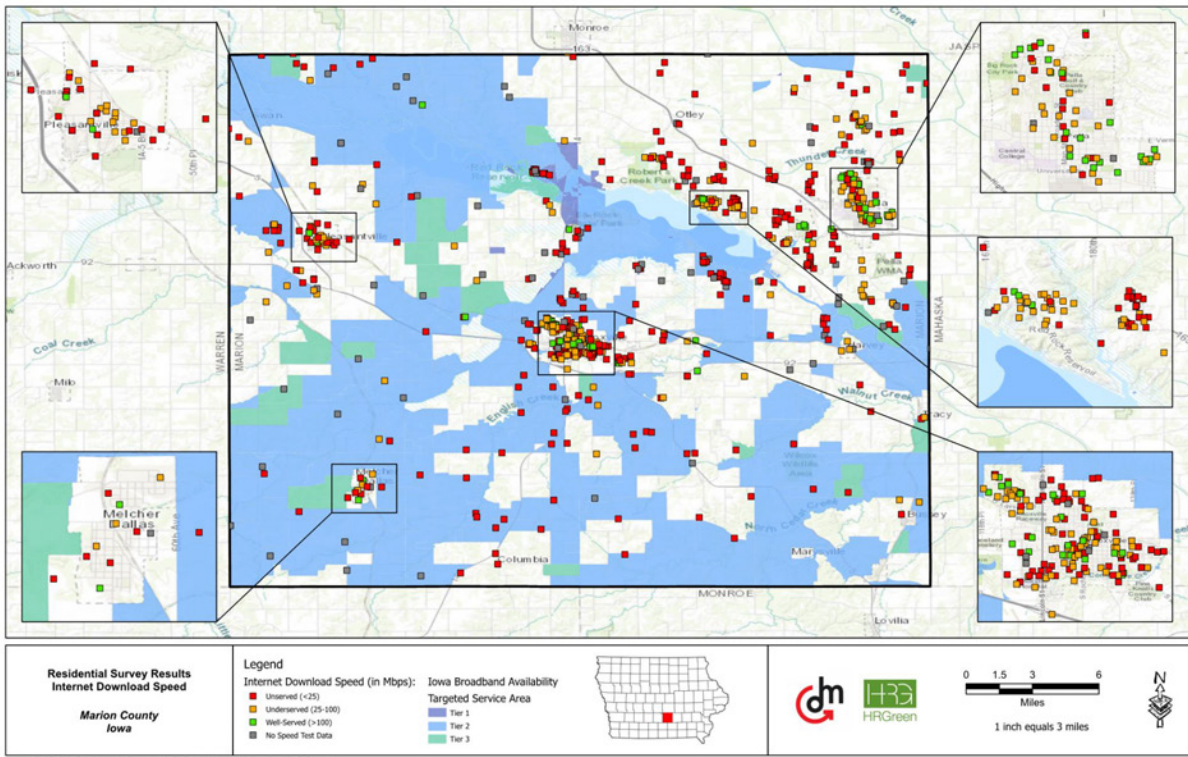

Figure 29 - Speed Test Results in Marion County

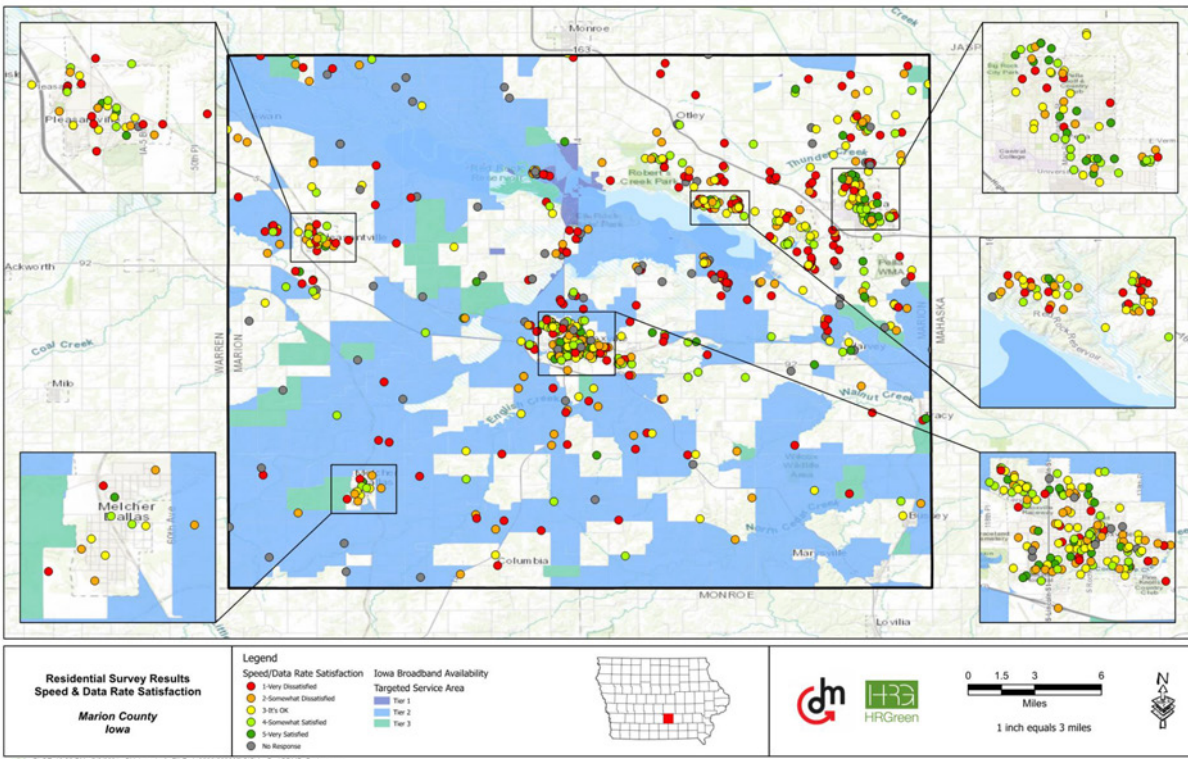

Figure 30 - Internet Satisfaction in Marion County

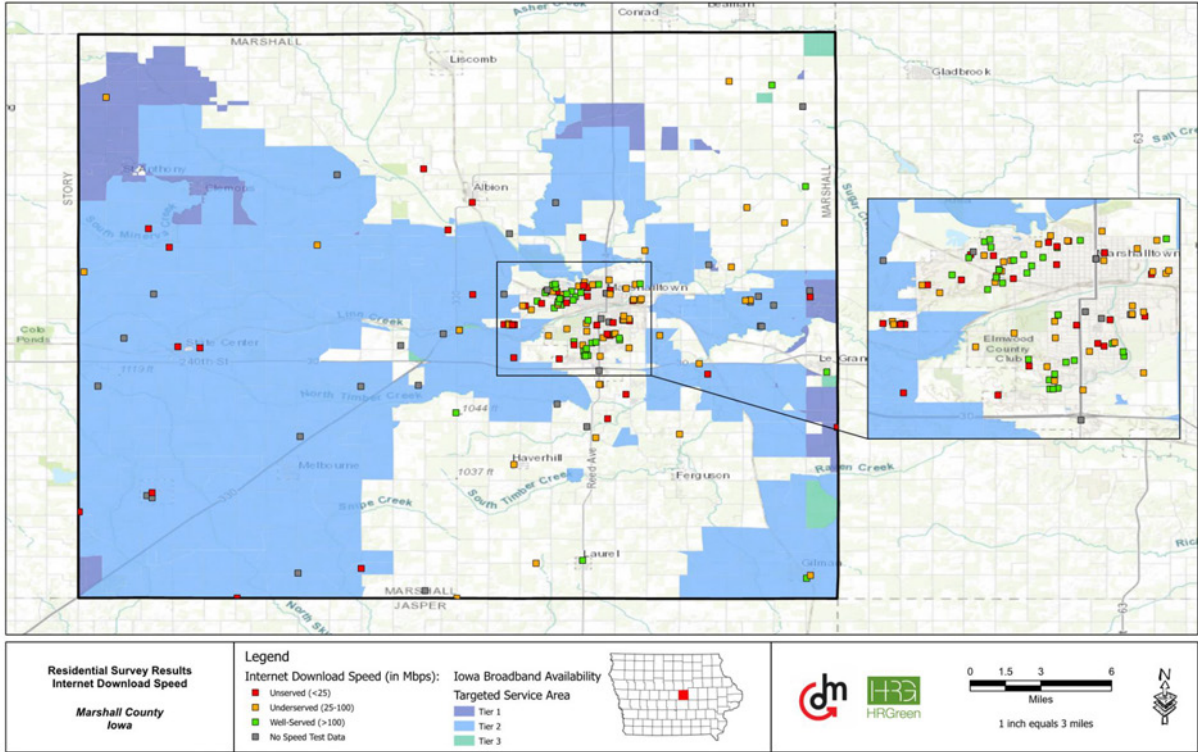

Figure 31 - Speed Test Results in Marshall County

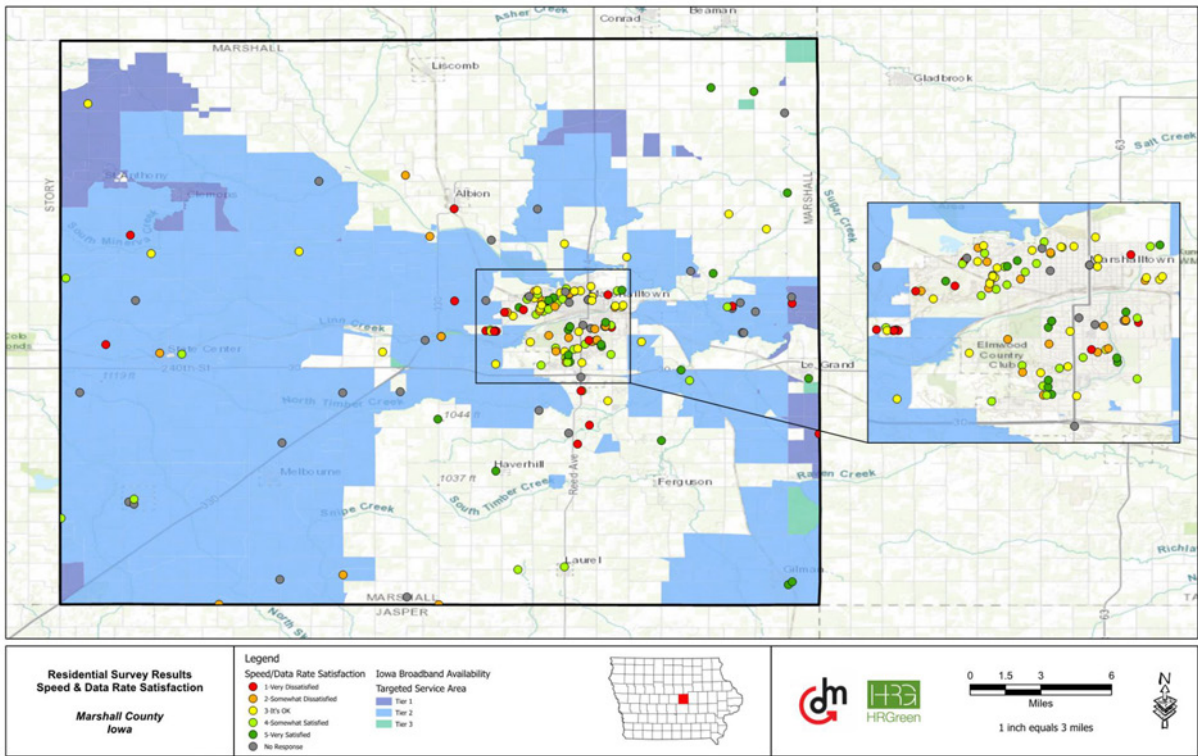

Figure 32 - Internet Satisfaction in Marshall County

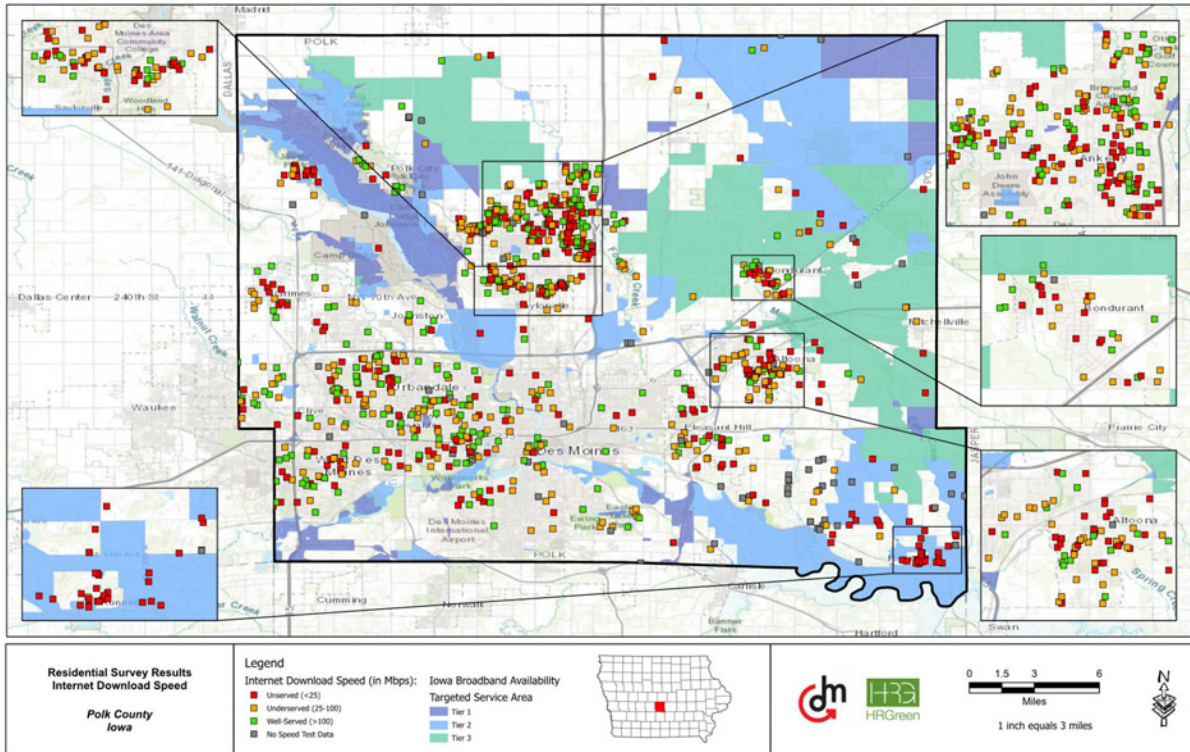

Figure 33 - Speed Test Results in Polk County

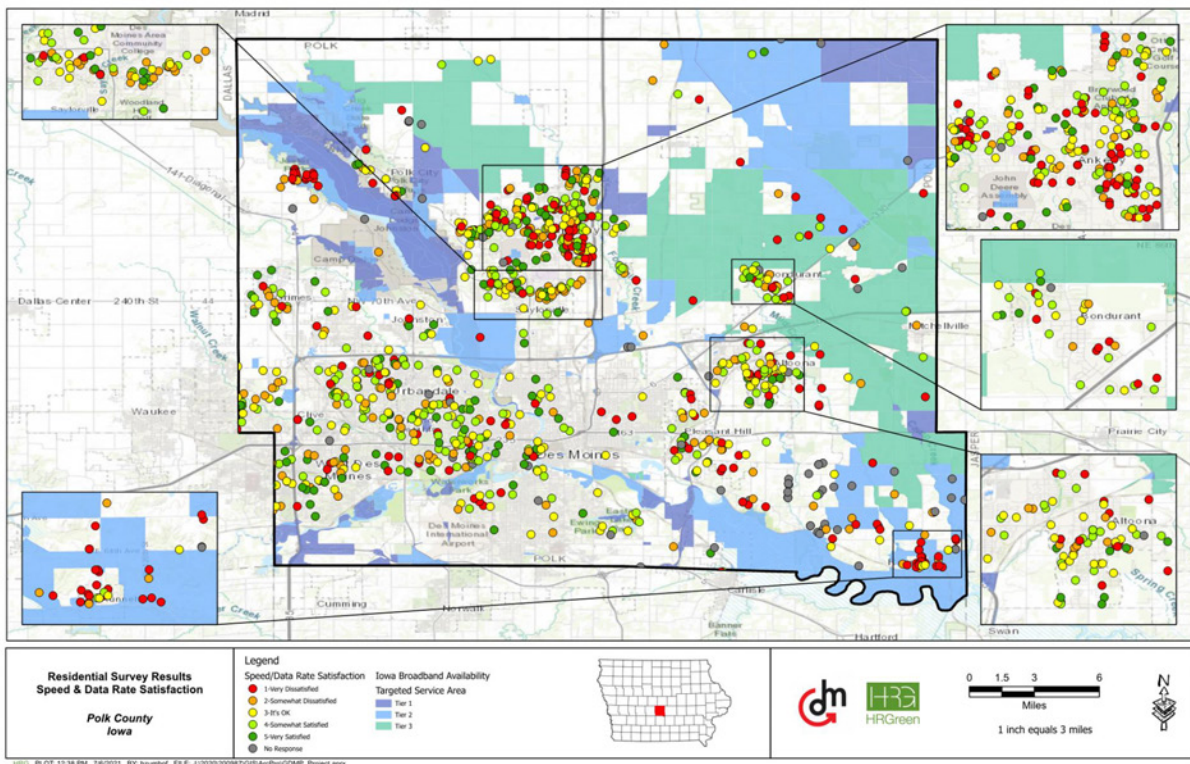

Figure 34 - Internet Satisfaction in Polk County

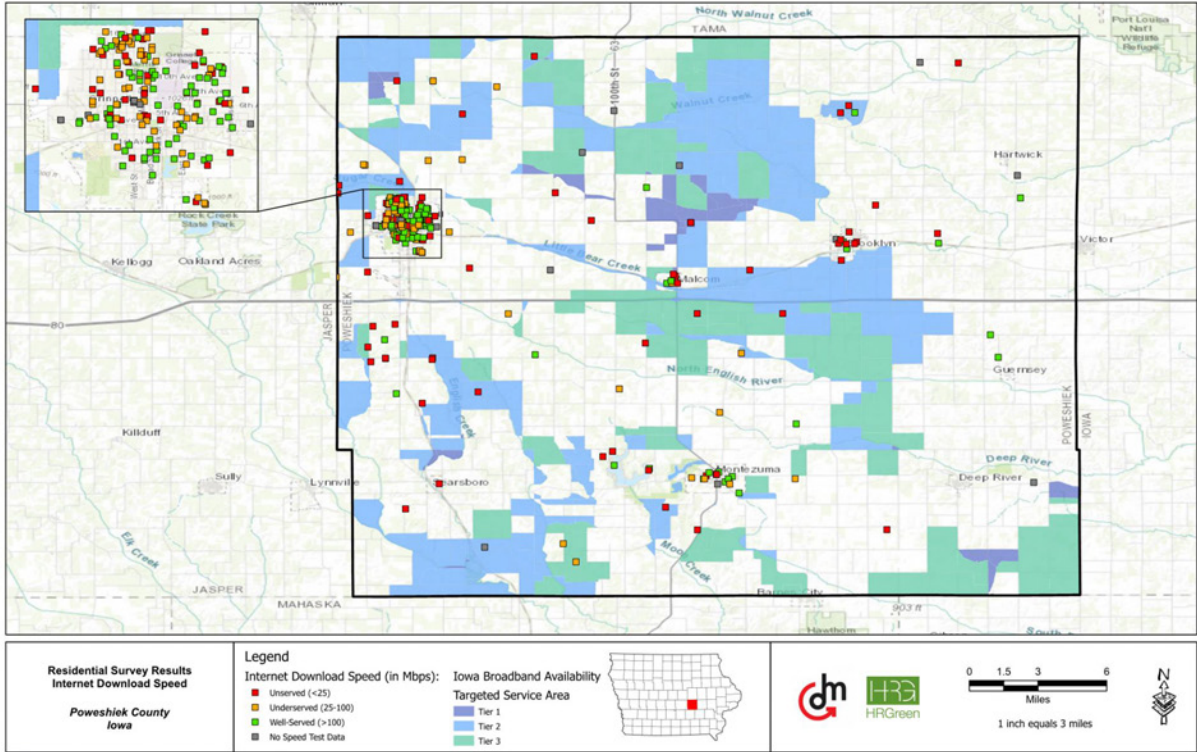

Figure 35 - Speed Test Results in Poweshiek County

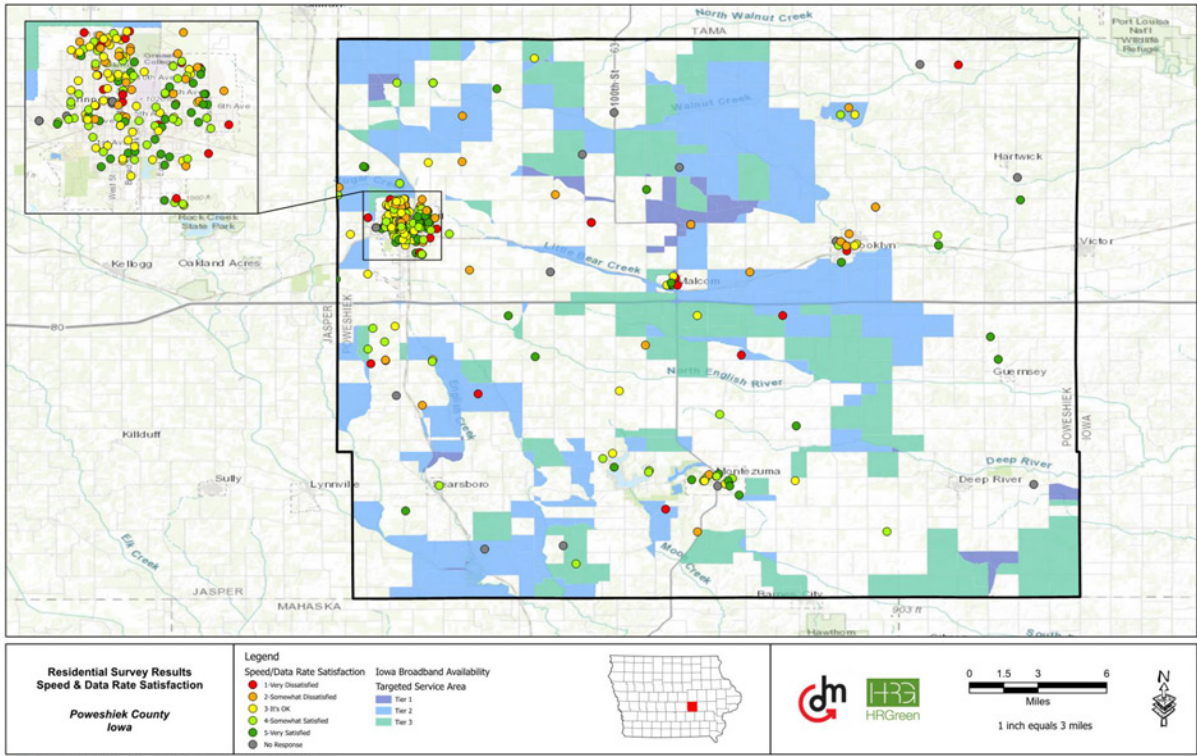

Figure 36 - Internet Satisfaction in Poweshiek County

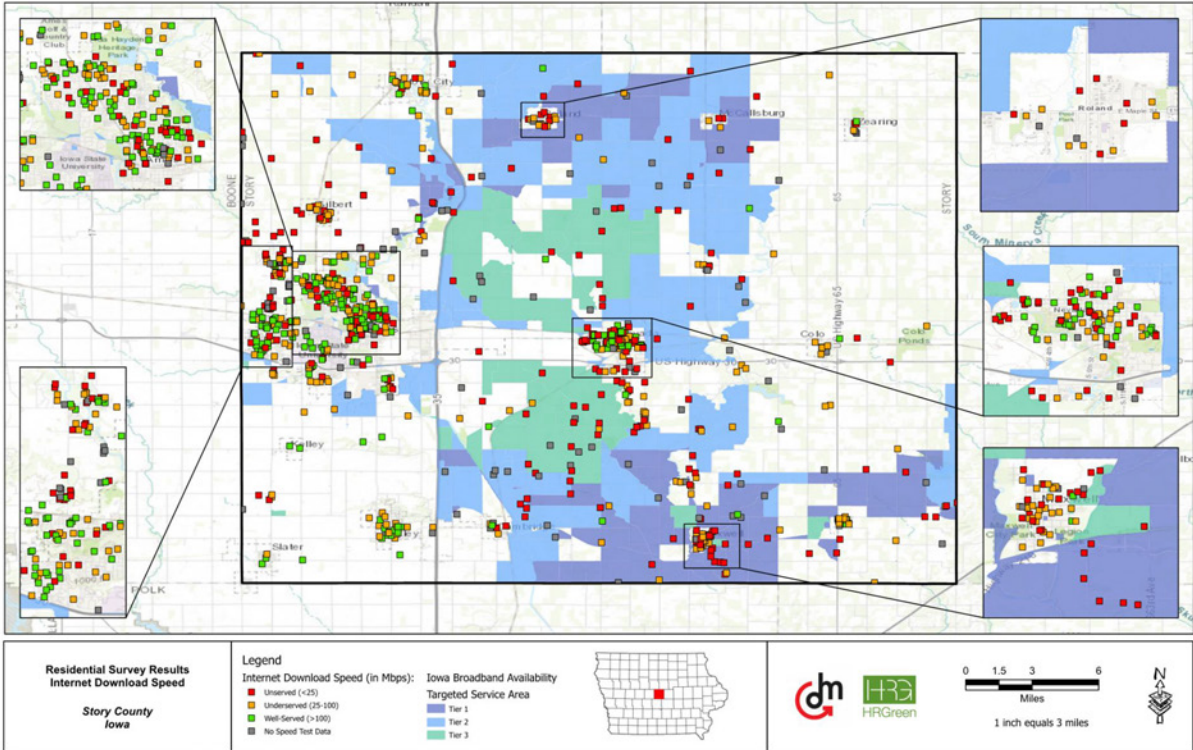

Figure 37 - Speed Test Results in Story County

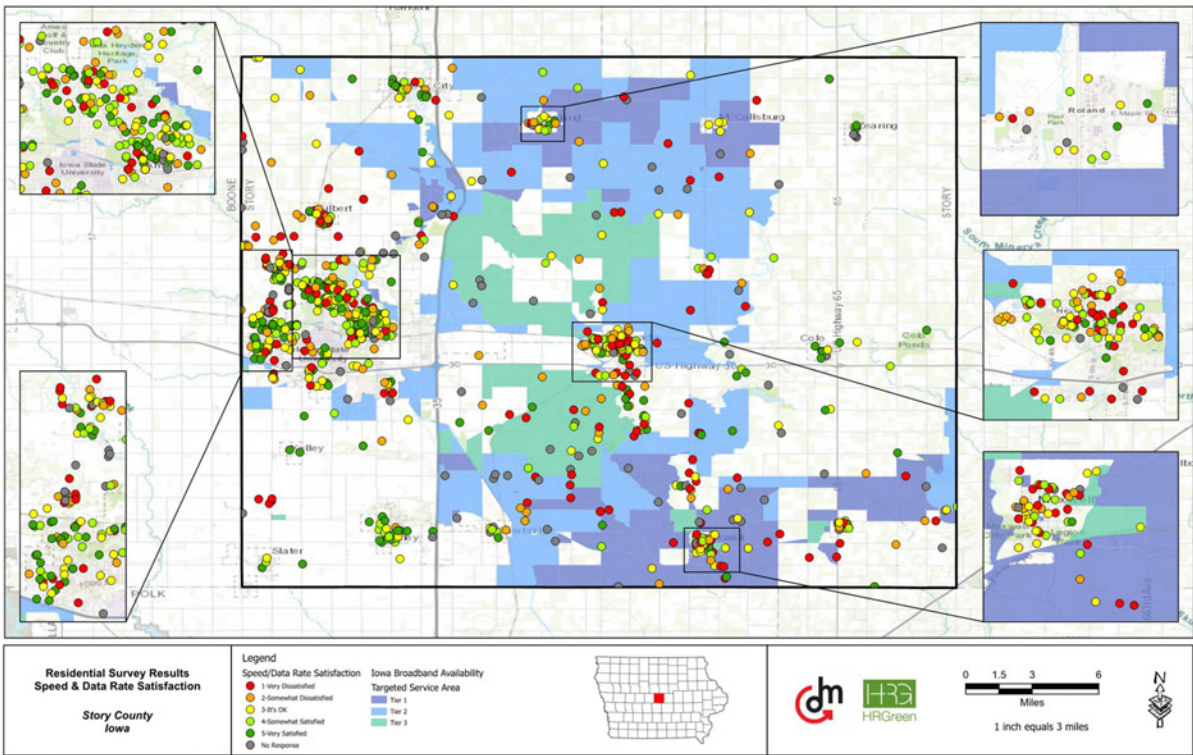

Figure 38 - Internet Satisfaction in Story County

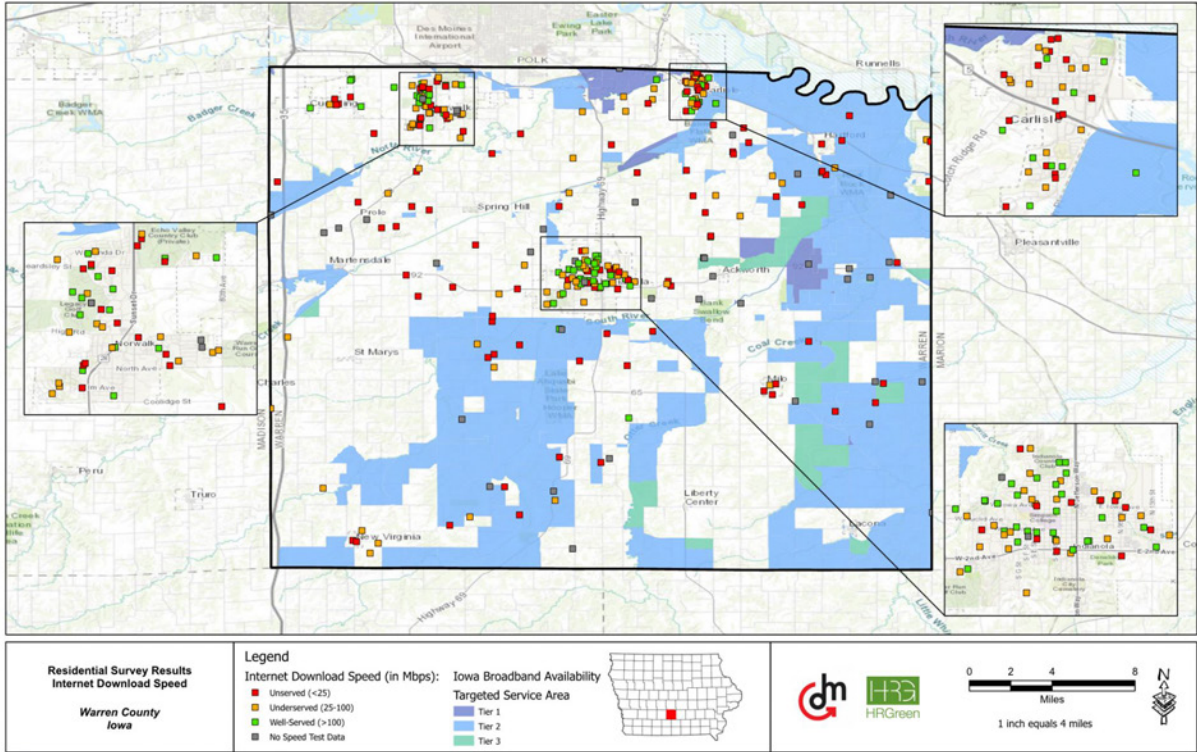

Figure 39 - Speed Test Results in Warren County

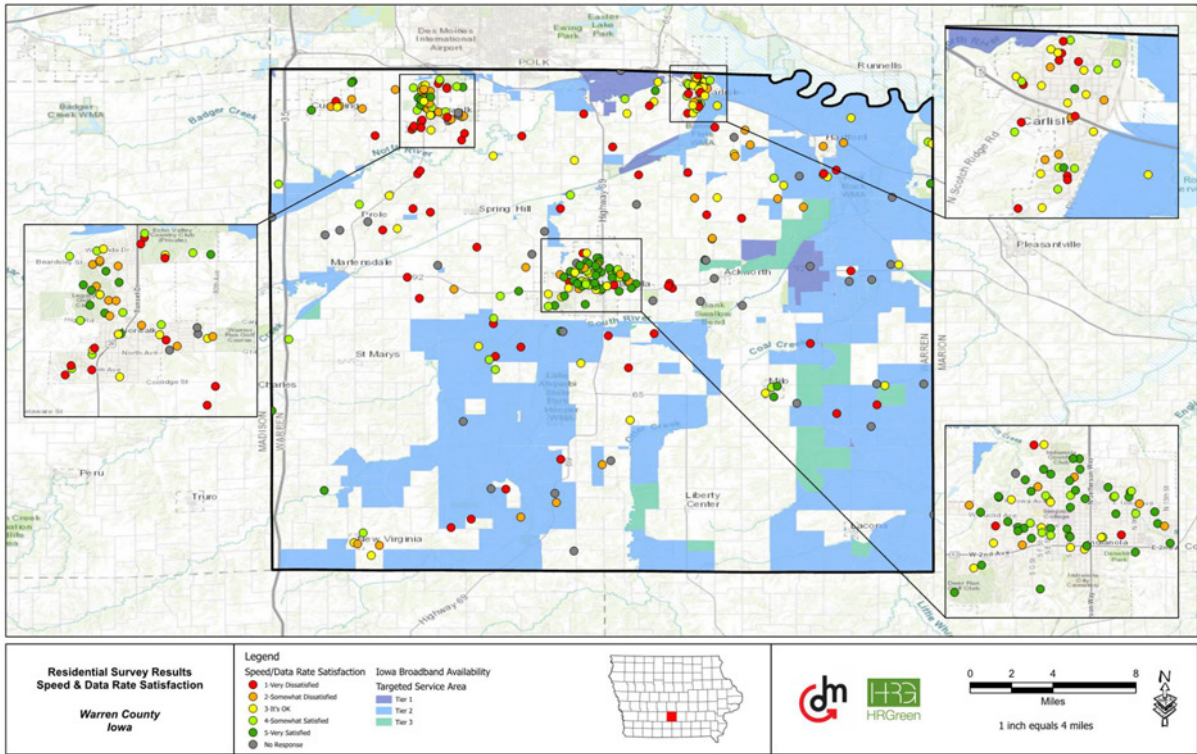

Figure 40 - Internet Satisfaction in Warren County

## Appendix D – Public Policy Whitepaper

The Fiber to the Home Council publishes best practice articles and is a recognized thought leader in the creation and execution of policies that advance the deployment of fiber optic in cities, counties and communities across the United States. The White Paper below was published by the FTTH council in early 2018 and summarizes best policy practices to enable the creation of broadband currency.

### **DIG SMART: Best Practices for Cities and States Adopting Dig Once Policies**



#### Executive Summary

Advanced fiber networks and high speed broadband are increasingly important to a community's quality of life and a healthy local economy. An essential step to deploying broadband is installing conduit and fiber, often in underground trenches where other similar infrastructure is also located. This installation process requires excavators to dig in the public rights-of-way, frequently in areas that are already paved or developed. Excavation is both disruptive to the community and expensive for the service provider.

Cities and states can reduce excavation costs, minimize disruption in public rights of way, and encourage broadband deployment through "Dig Once." Dig Once encompasses several approaches to installing conduit in conjunction with other compatible construction projects.

This paper focuses on the most impactful form of this policy: governments installing conduit whenever there is underground construction in the public right of way -- whether that construction is for installing new utility equipment, repairs, or road work. The government then has the opportunity to lease that conduit to broadband providers that are interested in deploying fiber networks to the community. This approach benefits the community by facilitating broadband entry and by giving the government an ongoing revenue source. In fact, as we will show, these revenues can more than make up for the initial capital expense. While some governments may be hesitant to pay for conduit themselves because of its short-term budget impact, they can recoup that investment over time while also creating significant benefits from the community.

To distinguish it from other types of "Dig Once" policies, we call this approach "Dig Smart". This paper lays out the benefits of Dig Smart, how to implement Dig Smart, and the practical implications of Dig Smart.



## **DIG SMART POLICIES BENEFIT LOCAL COMMUNITIES**

Dig Smart benefits local governments and residents by promoting the deployment of advanced fiber networks and broadband competition. Dig Smart policies mandate the installation of conduit throughout public rights-of-way, lowering costs for providing broadband service and making a community more attractive for broadband providers hoping to break into a new market or expand their existing operations. The resulting competition leads to more choices and lower prices for consumers. In addition, Dig Smart policies decrease the frequency of inconvenient and possibly dangerous construction along roadways, protect the reliability of broadband networks, and incentivize providers to lay fiber underground, hiding unsightly equipment and beautifying the community.

### **Dig Smart Promotes Competition in Broadband, Which Benefits Consumers**

Lack of competition is a serious problem in the broadband market. The Federal Communications Commission found that nearly 75% of homes have at most one choice in a provider of fixed internet access at download speeds of 25 Mbps (the current definition for “broadband” and the minimum the FCC says is necessary to access the most advanced online applications).<sup>i</sup>

Without competition, consumers often are charged higher broadband internet access prices. The Center for Public Integrity conducted an international comparative study on broadband competition, looking at the differences between comparable U.S. and French cities.<sup>ii</sup> The French cities, on average, had seven choices in broadband service providers, whereas the U.S. cities averaged out to two choices.<sup>iii</sup> In the U.S. cities, prices for broadband were up to three and a half times higher than in the French cities.<sup>iv</sup>

One of the primary reasons competition is lacking in the broadband marketplace is that the barriers to entry are so high. The upfront costs of deploying broadband service are enormous – particularly for the most advanced fixed residential broadband service, Fiber to the Premise. The most expensive part of deploying advanced fiber networks is the physical installation of conduit to hold the fiber, due to the costs of excavation.<sup>v</sup> Indeed, the Federal Highway Administration estimates that it is ten times more expensive to install fiber where the provider has to excavate and repair an existing road than it would be to install fiber in conjunction with other roadwork.<sup>vi</sup>

Dig Smart policies specifically address the costs of excavation in installing new conduit. San Francisco estimates that implementation of its Dig Smart law will lead to cost savings in excavation ranging from 25%-33%.<sup>vii</sup> By minimizing the costs associated with conduit installation with a Dig Smart policy, more broadband providers will be able to compete in the marketplace and deploy broadband services. This will promote greater competition, which will foster lower prices, prompt incumbents to engage in more consumer-friendly behavior and lead to more choices for a community’s residents.

## **Dig Smart Reduces Disruptive Repeated Excavation**

Installing equipment underground is disruptive, especially in areas that are already paved or developed or have underground infrastructure present. Excavators must first work through the jurisdiction's "locates" system to notify existing underground infrastructure owners and then those owners must mark the location of their facilities. Then the excavator must dig trenches where the conduit can be installed, which typically involves jackhammering through pavement. The excavators must surround the trenches with barricades, warning devices, and covers because the trenches are usually where people will encounter them. With each additional excavation, communities face risks to public safety, traffic disruption, risk of property damage service outages, and wasted government resources.

**Traffic Disruption and Road Deterioration.** Putting conduit underground alleviates crowding in urban public space, but the issues associated with excavation are exacerbated in these urban areas. Excavation along roadways will often halt or impede traffic, sometimes for lengthy periods of time,<sup>viii</sup> and create traffic congestion that increases vehicular accidents and wastes commuters' time. In addition, without Dig Smart, construction initiated by a broadband provider is often re-excavation, meaning that many roads have been excavated previously to install underground infrastructure. Like an article of clothing that is patched and patched again, repeated excavation damages the integrity of the road and shortens its lifespan.<sup>ix</sup>

**Public Safety and Service Outages.** Excavating where utilities already exist comes with other risks. Although state authorities require various locates processes before excavators may begin digging,<sup>x</sup> there is always the chance that the excavator may inadvertently damage existing equipment underground, sometimes because the underground equipment operator failed to accurately mark its facilities.<sup>xi</sup> Fiber is often installed alongside established utility infrastructure (e.g., gas or electric). Any damage to those pipes or cables could cause a serious disruption of services and harm to surrounding property. The math is simple: the more often excavations occur around existing utilities, particularly for distribution of natural gas, the more likely that gas lines or other utilities are struck resulting in significant risks to life and property.

**Wasted Governmental Resources.** Underground conduit installation requires time and resources from both the excavator and the government. Because excavations involve public safety and environmental concerns, there are a number of legal and regulatory hurdles to approving a dig.<sup>xii</sup> Excavation usually requires permits from the state or local permitting authority.<sup>xiii</sup> Indeed, if the excavation extends through a wide area, the excavator may need to seek permits in multiple jurisdictions. Further, governments will sometimes undertake (or require the excavator to undertake) environmental reviews for excavations, depending on how extensive the excavations may be.<sup>xiv</sup> Governments must spend time and resources that could be conserved by only having to do the permitting and reviewing once.<sup>xv</sup>

## **Dig Smart Incentivizes Installing Fiber Underground**

With Dig Smart in place, broadband providers can more easily and cost-effectively install fiber underground. Thus, the policy encourages broadband providers to choose to place their fiber underground rather than along utility poles. Undergrounding fiber has some significant advantages, including better service reliability and more attractive neighborhoods.

**Service Reliability.** Underground fiber improves the reliability of broadband services.<sup>xvi</sup> Unlike fiber attached to exposed poles, underground fiber is protected from ice, falling trees, high winds, natural disasters, lightning, sabotage, and other types of destruction, as well as decaying pole infrastructure.<sup>xvii</sup> This leads to fewer outages. Fiber on poles also requires more maintenance, such as trimming trees to prevent them from interfering with the lines, as well as other repairs from normal wear and tear of open-air exposure.<sup>xviii</sup> Placing lines underground therefore reduces the costs of providing service and facilitates competition.

**Aesthetics.** Communities generally prefer to have fiber underground for aesthetic reasons as well because it eliminates unsightly utility poles and hanging lines that obscure the landscape.<sup>xix</sup>

## HOW TO IMPLEMENT DIG SMART

Dig Smart mandates government installation of conduit whenever excavation occurs in the public right-of-way and where government-owned conduit does not already exist, whether a private entity is excavating, or the government is digging for a public works project. Dig Smart includes requirements that developers of new subdivisions install conduit or other appropriate or necessary communications infrastructure to each residence in the subdivision and in public or homeowner's association rights-of-way in the subdivision. With mandatory conduit installation, the Dig Smart approach is for the government to pay for the extra incremental costs of laying down the conduit, with the government retaining ownership of the installed conduit.

Dig Smart also minimizes legal controversies; unlike with respect to a private service provider installing underground infrastructure on private property, the applicable government entity already possesses authority to control construction in the public rights-of-way. Governments also possess broad latitude to condition the grant of construction permits in the public rights-of-way.<sup>xx</sup> Even in states where municipal broadband is restricted,<sup>xxi</sup> Dig Smart is an appropriate and lawful approach; municipalities would not be running afoul of such restrictions on providing service, as the conduit itself is not a service but only a facility.

With Dig Smart, conduit is installed as excavation occurs, gradually increasing coverage of the conduit network around the community with each new construction project. Dig Smart makes the community ready for deployment of advanced broadband services and eliminates additional excavation necessary to make those services a reality. In addition, service providers do not have to shoulder the added burden of seeking trenching partners or paying for the costs of conduit installation, and thus the opportunity to lease government conduit will encourage them to build a fiber network in the community. By maintaining ownership of the conduit, the

government generates revenue by leasing those valuable assets out to broadband providers interested in providing fiber service to the community. Dig Smart works for the community and works for the government.

For governments desiring to reap the community benefits of adopting Dig Smart, model legislation is included in Appendix A.

### How Dig Smart Works for Governments in Practice Governments

Governments can use Dig Smart as a source of potential revenue, once the municipality or other governmental authority has installed enough conduit to interest broadband providers in leasing. With a private excavation project, the government typically would pay the costs for materials (the conduit itself), installing the conduit in the excavated trench, and any design variations in a private excavation project required to facilitate conduit installation. For public works projects, the government can install conduit in conjunction with existing construction much less expensively than would

be possible in a separate excavation and installation project. The costs of conduit, including materials and installation, are slight relative to the expenses for digging up and repairing the ground.<sup>xxii</sup> Sample road and underground construction costs from various cities generally run from \$200,000 per mile for something like a sewer replacement to \$10 million per mile for larger road system construction.

xxiii

In contrast, the average cost of the conduit itself is around \$10,000 per mile (or around \$1.90 per foot), making it 0.1% to 4.3% of the total cost of any given excavation project.<sup>xxiv</sup>

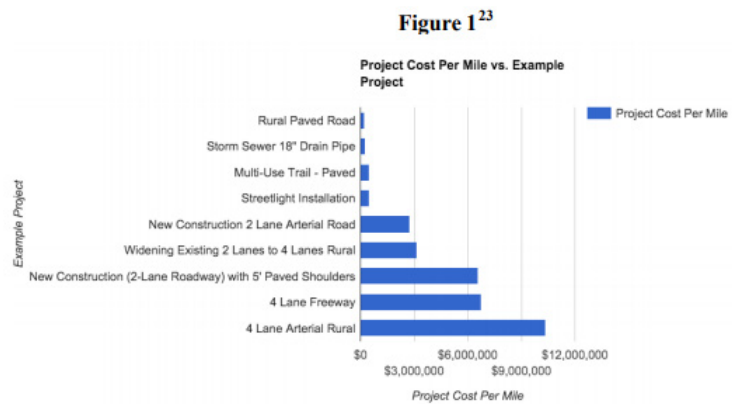
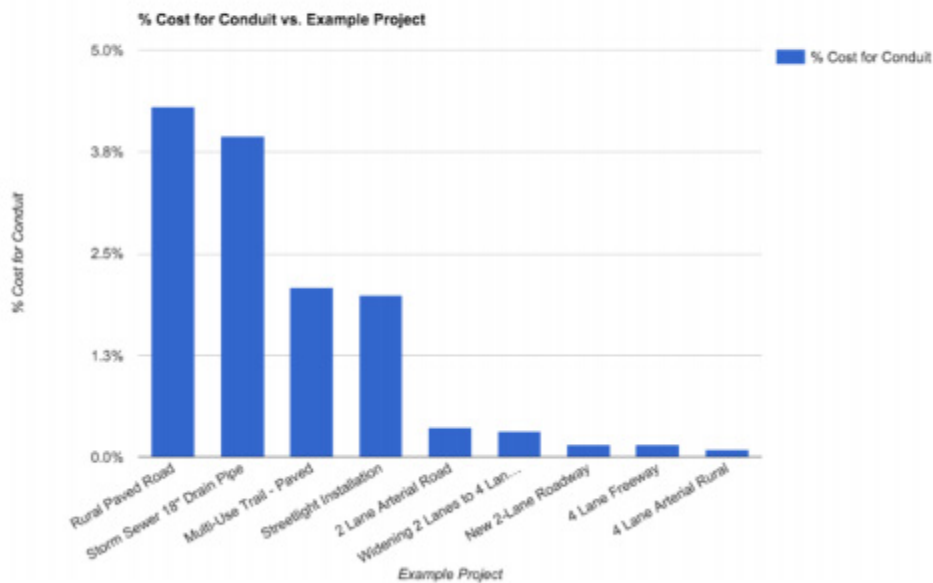

Figure 2<sup>25</sup>



Dig Smart does require the government to pay certain upfront construction costs on top of the actual cost of the conduit itself. Installation will often require additional fees for design changes in trenching—the trenching required for sewer lines, for example, may not be the kind typically used for conduit and accommodating those changes will incur design costs. Other additional costs may include extra labor fees for installation. However, the cost of installation should be considered an investment. Governments can usually install conduit at a discounted rate per linear mile as compared with private utilities.<sup>xxvi</sup> Moreover, after installation, the government will own the conduit and, because it is in the public right-of-way, the government will not owe any licensing fees to any landowner on which the conduit is located. The government would then lease the conduit to a broadband provider and recover the modest costs of installation.

The following example shows how quickly the government would be able to recover its investment. Assume the cost of the conduit itself and extra conduit installation fees (independent of the main excavation costs) is \$25,000 per mile (or \$4.73 per foot).<sup>xxvii</sup> Private service providers typically lease installed conduit for between \$0.65 and \$0.80 per linear foot of conduit per year. With a lease rate of \$0.65 per linear foot of conduit annually, a local agency would more than recover its upfront installation costs after 8 years of leasing (8 x \$0.65 = \$5.20).

The 8-year period here is a minimal estimate, too, especially if the government manages to secure multiple lessees. Where the government installs conduit with multiple duct banks to accommodate multiple providers, it can recover costs more quickly with adequate demand. The additional revenue could be used for a number of purposes, including covering internal costs for managing the public rights-of-way. Below is an example on calculating a return on

investment (“ROI”), assuming a lease to just one broadband service provider. Fiber Installation Cost (per mile) \$25,000 Fiber Lease Rate (per mile per year) \$3,432 (or \$0.65 per foot) 10-Year Income \$34,320 Return-On-Investment (ROI) Example 37%

Fiber Installation Cost (per mile)	\$25,000
Fiber Lease Rate (per mile per year)	\$3,432 (or \$0.65 per foot)
10-Year Income	\$34,320
Return-On-Investment (ROI) Example	37%

To protect its investment in the conduit and discourage re-excavation, a government can also require that new broadband providers use existing conduit to the maximum extent feasible. Of course, the government is unlikely to obtain lessees immediately upon implementing Dig Smart legislation. Broadband providers would want to lease conduit after the community has a critical mass of conduit network already in place, and the actual recovery time of installation costs will depend on when broadband providers lease the government’s assets. Accordingly, governments interested in Dig Smart should enact legislation as soon as possible, because the benefits of Dig Smart begin to accrue as more excavation projects are undertaken. Once Dig Smart is in place, a government can begin building up enough conduit to begin leasing it to generate revenue in excess of costs.

## **OTHER WAYS TO ENCOURAGE DIG SMART**

States too should be interested in bringing more broadband options to their citizens. States, of course, can implement Dig Smart policies and install conduit when excavating rights-of-way under state jurisdiction. Although states do not control access to local rights-of-way, states can encourage Dig Smart policies at the municipal level in at least two ways.

First, states may adopt resolutions or other legislative policies that encourage municipal enactment of Dig Smart laws.<sup>xxviii</sup> This allows states to signal support for Dig Smart at no cost to the state.

Second, states may consider creating a monetary incentive for municipalities to adopt Dig Smart laws. States could condition grant of certain funds for local governments based on the local government implementing a Dig Smart policy. For instance, state road construction funding could be conditioned on the locality installing conduit that will increase the opportunities in the local community for better advanced communications services.

## **OTHER “FLAVORS” OF DIG ONCE**

Dig Smart is the gold standard of Dig Once. There are other types of Dig Once that are unlikely to be as effective as Dig Smart but nonetheless encourage broadband deployment while

reducing the burdens of additional excavations. These other types of Dig Once are described here and compared to the advantages of Dig Smart. The primary other “flavors” of Dig Once policies and laws are: (1) coordination, (2) voluntary joint trenching, and (3) mandatory joint trenching.

**(1) Coordination.**<sup>xxix</sup> Coordination requirements help inform interested excavators, such as broadband providers, when underground or road construction is going to happen so that they can be prepared to install equipment in conjunction with scheduled excavations. Coordination is facilitated by governments establishing a “coordination database” and requiring underground facilities owners to update the coordination database with information on upcoming scheduled excavation. Interested excavators may then use this database for coordinating underground facilities installation with existing planned construction.

A coordination policy requires governments to expend resources on organizing and posting information from different entities. While a coordination policy would help some enterprising service providers in identifying excavation areas where they could potentially coordinate installation of their equipment, the marginal benefits of this are low, and it in no way guarantees that conduit will actually be installed. Coordination databases rely on the existence of other interested entities to effectuate infrastructure deployment. Where no service provider is already building in the market and therefore monitoring the database, opportunities to install conduit when there is planned excavation in the public rights-of-way may be missed. Moreover, this policy by itself does not allow the government to control for quality or for competition maximizing conduit that has room to accommodate more than one fiber cable. Finally, with coordination, any installed conduit will be the property of the private entity, rather than the government. The government, therefore, has little direct opportunity to earn a return from implementing a coordination policy.

**(2) Voluntary Joint Trenching.** Voluntary joint trenching requires entities that have received approval to excavate in public rights-of-way to formulate construction plans, and schedule construction, with other service providers that are interested in installing or maintaining equipment in public rights-of-way.<sup>xxx</sup>

Voluntary joint trenching (in contrast with mandatory joint trenching, discussed below) is termed “voluntary” because the policy relies on other excavators volunteering to jointly trench for the Dig Once benefits to be realized. (The initial excavator is required, however, to formulate construction plans with and schedule construction with other service providers that want to jointly trench.) The disadvantage of this approach to Dig Once is that if no broadband provider comes forward within the allotted time after the lead excavator notifies of an excavation, then no conduit would be installed. Interested service providers could miss the window for joint trenching and end up having to re-excavate. Indeed, a provider that does not yet exist by definition cannot take advantage of this opportunity. Voluntary joint trenching has many of the same drawbacks as a coordination policy. Ultimately, this policy would encourage more efficient excavations (and additional deployment of broadband network infrastructure) but not guarantee it. Although governments should not depend on voluntary joint trenching as

a reliable means of achieving Dig Once objectives, if companies wish to jointly trench, governments should not prevent them from negotiating a private solution to excavation and conduit installation. Industry-driven initiatives in joint trenching can work in tandem with Dig Smart laws to minimize excavation and maximize installation of conduit.

**(3) Mandatory Joint Trenching.** Mandatory joint trenching requires all potential excavators to install their infrastructure in the same trench at the same time. All parties then split the costs of the excavation.<sup>xxxii</sup> A mandatory joint trenching law would require that all excavators determine a “lead.” That lead excavator would then approach the city to receive a “joint trench” permit on behalf of all the service providers installing underground infrastructure in the excavation. Mandatory joint trenching makes installation of conduit more certain than with voluntary joint trenching, as broadband providers must install conduit where it does not already exist as part of the joint trenching. Some municipalities with this type of joint trenching also have an enforcement clause that prevents re-excavation within a certain amount of time.<sup>xxxiii</sup> But these restrictions on re-excavation (often called moratoria) can delay broadband deployment and discourage competition if an interested broadband service provider misses the window. If broadband providers miss the period for joint excavation, they could be barred from re-excavating for years. This delay would work against the goals of Dig Once, which include deploying more broadband for consumers. In addition, other types of non-broadband excavators could be shut out from installing important equipment for their services. Ultimately, these unintended consequences could hurt various service providers and local residents.

## CONCLUSION

High-speed broadband internet access brings greater prosperity and convenience to communities. Local and state government policy therefore should facilitate more competition in the broadband market. Dig Smart is a win-win policy for states and municipalities, as residents benefit from broadband competition (bringing faster service at lower prices) and less excavation disruptions. Unlike some other government initiatives, Dig Smart has the potential for government to recoup funds spent on public works through leasing of conduit. Dig Smart is the best way for communities to accelerate deployment of the fastest, most advanced broadband and should be seriously considered by any city or state that wants to bring better services to its residents.



## Appendix E – Financing Options Whitepaper

### S.F. 390

#### Potential Proposed Enhancements

**Challenge:** Smaller and local Iowa service providers, both current and new entrants receiving RDOF and other federal dollars, are not as easily able to build out Targeted Services Areas (see bill definition) due to financing constraints. This also limits the development of effective public/private partnerships to build networks with providers able to otherwise leverage the issuance of revenue bonds.

**Proposed Solution:** Develop a project-based funding process by which Targeted Service Areas self-aggregate by providers to be included in an Iowa Finance Authority (IFA) Broadband Development Loan pool that: (1) pools startup financing risks across statewide projects that are pre-screened for financial viability, (2) establishes approximately 50% quasi-equity from which a provider can borrow remaining funds, and (3) leverages private equity, federal funding and private bond investors actively seeking to invest in Iowa's broadband infrastructure.

- The **IFA** would issue up to \$250 million of bonds annually collateralized by: (1) first revenues from providing broadband services by the provider, and (2) conduit and fiber constructed by the provider. Working capital and electronic equipment must be funded by local or other sources.
- The **Empower Rural Iowa fund** shall provide credit enhancement to that year's bond series by placing \$50 million into an escrow account, or alternatively pledge such payment from State of Iowa General Fund Reserves, for a period not to exceed the first 10 years of the series. The State of Iowa can then either re-appropriate the funds into another credit enhancement or release them into another purpose after the 10-year period expires to the extent the credit enhancement funds were not used.
- Provider to borrow an additional 10% of project costs to be held as a debt service reserve, held in escrow by the IFA, for the first 5 years of a funded project.
- Providers are required to have rates and charges sufficient to have net margins at projected 1.1x debt service requirements (similar to water and sewer projects funded through IFA financing) in years 5+.
- Each provider may be released from its collateral obligations upon full repayment of its portion of the bonds issued in any series. IFA to hold funds in escrow in the event of early repayment.

## 8B.11 Changes:

**Amend Paragraph 1.** “by awarding grants to communications service providers and pooled loan facilities including those issued or authorized by the Iowa Finance Authority.”

**Challenge:** Service providers are extending service areas in many cases, and should be credited for middle mile, partnership, and adjacent fiber feeder lines recently installed as their local match to build to a new area that directly benefits from those previous investments. This includes middle mile transport, which is needed to serve areas using a regional approach. Investing in studies demonstrating market demand and commercial viability should also be both credited and encouraged through prioritization. The timing of phased projects also needs to be considered, particularly where phases may be funded by different sources.

**Proposed Solution:** Encourage partnerships, market aggregation, and the interconnection of projects under the grant criteria paragraphs in **8B.11**:

**Amend Paragraph 4(a)(2)(a).** “The amount or percentage of local or federal matching funds, funding obligations shared between public and private entities, and fiber optic, transport, and broadband equipment investments made by the applicant(s) and its partners in adjacent Targeted Service Areas within the past 5 years having a minimum download speed and upload speed of greater than or equal to one-hundred megabits per second that also directly benefit or serve the Targeted Service Area(s) project(s).

**Amend Paragraph 4(a)(2)(b).** “The percentage of funding provided directly from the applicant(s)...

**Replace Paragraph 4(a)(7).** Other factors, which shall include and prioritize applicant(s)’ advanced preparation of market gap and demand studies, regional planning, independently- reviewed business viability modeling, shared transport, and other demonstrated cost-effective shared facilities and operations used to provide broadband service to the Targeted Service Area.

**Add Paragraph 4(a)(8).** Other factors the office deem relevant.

### Other Challenges not yet addressed legislatively that could enhance the program:

- Statewide project oversight to ensure integration between funded projects where it makes sense. This needs to involve IDOT (for rights of way or ROW management), the office of the CIO, broadband network industry professionals like engineering, IFA, and others.
- All submitted projects could be involved in an amendment or appeals process to see if a larger regional Targeted Service Area can be aggregated together somewhere

between the application and award process. This may also include consultation with IDOT to enhance regional impacts through ROW planning.

- Transparent and comprehensive asset mapping is critical to providing access at the sub-Census block level, which is not provided by the current FCC maps. The OCIO should be required to set up and maintain that platform under Section 2.(b), even if that means a larger percentage being allowed for overall administrative costs.
- Retail rates for service, commensurate for both the investments made by all parties, and that consider relative average household income within the Targeted Service Areas, do not appear to be a priority or funding consideration. Incentivizing the formation of a potential future monopoly, who may be able to raise rates indiscriminately in the future, should likely also be required to participate in a lower income retail rate program as a consideration for public funding. This would offset some of the public's upfront cost by benefiting customers who, after the debt for those costs have been recouped and construction debt has been repaid, can no longer afford a full retail rate (which inherently contains debt service costs).
- Consideration how to handle providers that get awarded public funding and then, post- construction, sell select customers within a, or an entire, Targeted Service Area to a 3<sup>rd</sup> party at a profit. Providers likely need to retain that ability for financing reasons, however there needs to be a determination where and how it is in both the public and customers' interests to do so.

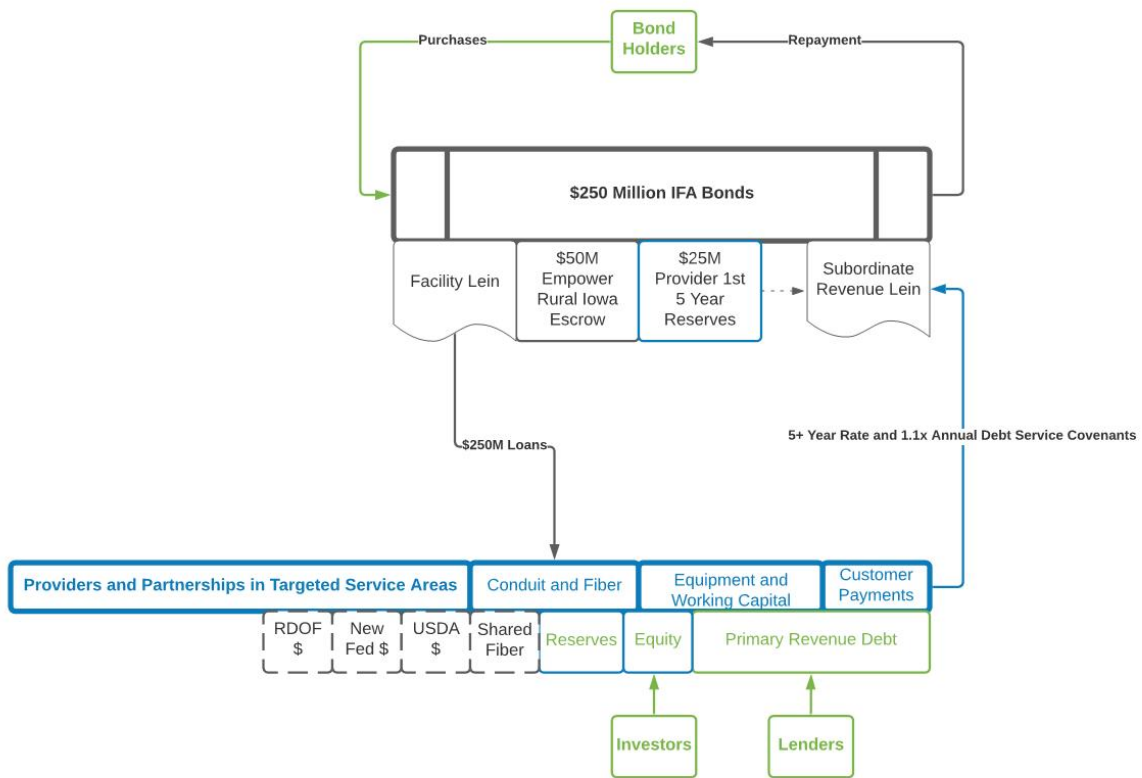

## Governor Strategies to Expand Affordable Broadband Access

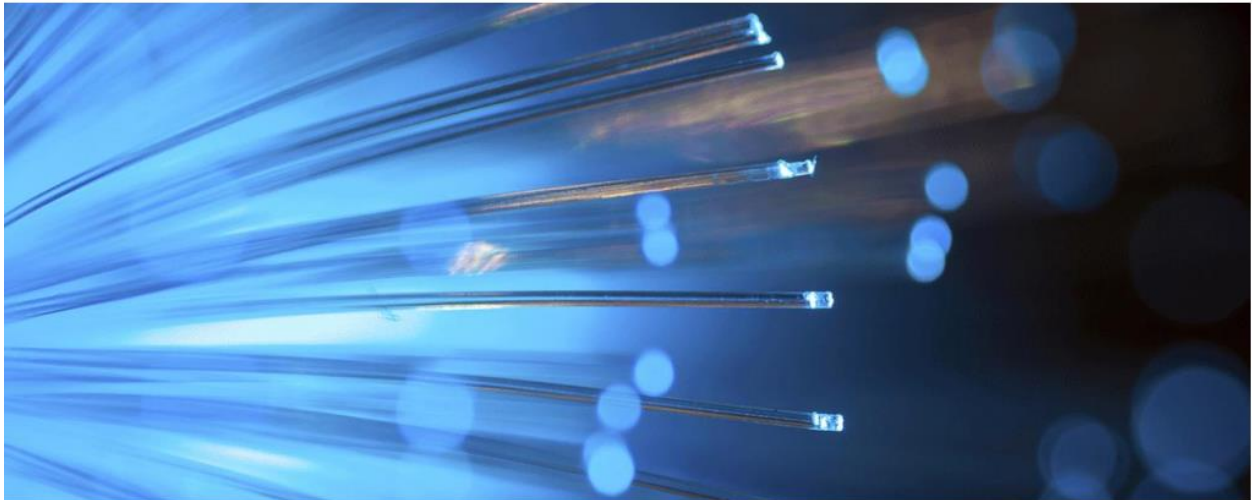

NATIONAL  
**GOVERNORS**  
ASSOCIATION

## Key Points

- **Increasing access to the internet and improving the affordability of broadband services has been a long-standing priority for Governors;** more than twenty states now have dedicated broadband offices to address the digital divide while more have robust governance structures that include task forces, working groups, and committees.
- **Access to high quality, affordable broadband unlocks access to commerce, remote work opportunities, remote and improved education, telehealth, intelligent agriculture, and more.** However, 18.3 million Americans, many in rural geographies, still lack access to even basic levels of broadband service and even more are unable to afford the service available to them.
- While the need for accessible and affordable broadband extends far beyond the current crisis, **the COVID-19 pandemic has added a newfound urgency to broadband expansion.** Connectivity has become essential for people to follow public health guidelines, school closures, and remote work requirements.
- As Governors increase state efforts to expand affordable broadband access, particularly in response to the ongoing pandemic, **several key strategies and best practices have emerged that can facilitate those efforts,** including to:
  - Establish robust, cross-cutting [governance structures](#)
  - [Initiate partnerships](#) with other state agencies, local and county governments, and other entities to kickstart broadband investments
  - Leverage [anchor institutions](#) to provide rapid community internet service
  - Leverage existing infrastructure projects with [dig-once coordination](#)
  - Leverage [electric utilities'](#) infrastructure and services to facilitate deployments of broadband networks
  - Coordinate and expand broadband [affordability programs](#)
  - Deploy [innovative procurement](#) strategies
  - Improve broadband [coverage maps](#)
  - Identify [funding and financing](#) sources for broadband deployment

## Background

According to the FCC, in 2018, at least 18.3 million people lacked access to fixed broadband in the United States that meets minimum internet speed of 25/3.<sup>1</sup> Of those 18.3 million people, representing 6 percent of the total population, 14 million live in rural areas and 1 million live on Tribal lands, which amounts to 22 percent and 28 percent of those respective geographic populations. In response to the pandemic, the U.S. Census Bureau conducted a series of household pulse surveys, which found that as of July 2020 an estimated 2.8 million people with children in school either never or only rarely or never have access to the internet for educational purposes.<sup>2</sup> Additionally, 4 million people with children in school are estimated to lack a computer or similarly suitable device. Further, studies have claimed that the FCC data is undercounting the number of people in the U.S. without fixed broadband access, and that the total may be as high as 42 million people.<sup>3</sup> As the minimum acceptable speed threshold is raised, access becomes more scarce—only 75 percent of Americans have access to broadband services that provides a faster 100 Mbps download and 25 Mbps upload.<sup>4,1</sup>

### What is Broadband?

U.S. code broadly defines “broadband infrastructure” and “broadband service” as any technology with the capacity to transmit data to enable a subscriber to the service to originate and receive high-quality voice, data, graphics and video.<sup>1</sup> The Federal Communications Commission (FCC) further defines the minimum internet speed of broadband to be a service that provides rates of 25 megabits per second (Mbps) download and 3 Mbps upload, referred to as “25/3” service.

In addition to lack of access, the cost of broadband services remains a considerable barrier for many households. According to research from BroadbandNow, only 51 percent of Americans have access to broadband that costs \$60 per month or less, however this may not reflect recent services and discounts providers have begun offering in response to the COVID-19 pandemic.<sup>5</sup> The international Broadband Commission for Sustainable Development sets a threshold for an entry-level affordable broadband service at 2 percent of a country’s average monthly income.<sup>6</sup> Adjusting that metric for each bracket of U.S. household income, a \$60 per month broadband service would be unaffordable for 28 percent of households. According to surveys from the Pew Research Center, 50 percent of those that lack access to broadband in the U.S. cite the monthly cost of the service as a factor.<sup>7</sup> Notably, survey data from the National Telecommunications and Information Administration (NTIA) estimates that in 2019, the number of people without internet access at home could be as high as 26.2 million, but that 60 percent of respondents cited a lack of “need or not interested” as the primary reason.<sup>8</sup>

Access to affordable broadband also has significant equity implications, as communities of color and low-income areas have seen lower rates of broadband adoption. As of 2019, NTIA surveys report 67 percent of Black and Hispanic adults had at home broadband

<sup>1</sup> Notably, the FCC census block-level service data, which the FCC acknowledges is imperfect, provides a slightly different picture, estimating that 90 percent of the U.S. population have access to at least one fixed residential broadband provider offering service with a speed of 100 Mbps download and 10 Mbps upload within their census tract.

services, compared to 77 percent of white adults.<sup>9</sup> While broadband adoption has increased over time for all populations, there has been a persistent racial gap in adoption rates. Surveys from Pew Research Center also show that adults making less than \$30,000 are half as likely to report having home internet access as adults making \$75,000 or more, with only 56 percent reporting access in 2019.<sup>10</sup> The COVID-19 pandemic has shone a spotlight on these broadband gaps and the need for universal coverage.

Fortunately, Governors across the country have made expanding affordable broadband access a core policy goal.<sup>11</sup> All 50 states and most territories have staff devoted to broadband activities, with more than 20 establishing dedicated broadband offices and 22 Governors specifically highlighted the need for broadband expansion in their 2020 State of the State addresses. At a recent NGA roundtable, several state, federal and policy experts discussed challenges and highlighted policy solutions for Governors to address coverage gaps, cost inequities and expand access to high quality, low cost broadband across their states. This paper will present the use cases for expanded broadband access and highlight best practices Governors can consider as they implement solutions to the most pressing connectivity challenges states face.

Challenges addressed by this paper include:

- An accelerated need for new affordable connectivity across sectors and end-uses for increased teleworking, telemedicine, online learning and e-commerce as a large share of the population in both urban and rural areas are isolated during the COVID-19 pandemic
- Data challenges and opportunities for states to identify and map coverage gaps
- Solutions to improve the affordability of broadband service and equity of broadband access
- The traditional economic business model challenges for middle mile and last mile connection in rural communities
- Federal funding, while critical, can be narrowly scoped and challenging to navigate
- The need to enhance digital literacy for newly connected individuals



## Use Cases

The COVID-19 pandemic has underscored the reality that many aspects of modern-day life, including commerce, health care, education and social activity, are dependent on connectivity. Layered across these uses are social, economic and geographic factors that limit equitable access. The pandemic exacerbates disparities caused by the absence of reliable broadband, but the need for accessible and affordable broadband extends far beyond the current situation. The list below outlines the many use cases that are motivating governors to seek expanded access to broadband.

**Telework:** One of the most immediate changes caused by COVID-19 was a massive workplace shift to teleworking for those who are able and not deemed essential workers. Nearly half of Americans are now working from home and many organizations may shift to increased remote work as a new paradigm.<sup>12</sup> While remote work is not possible across all industries or job functions, where it is, household connectivity is vital to maintaining a stable and engaged workforce. Expansive broadband will ensure that workers can remain connected and productive from home.

**Remote learning:** Students increasingly rely on connectivity for remote learning, yet as many as 12 million K-12 students lack internet access at home.<sup>13</sup> Further, broadband access also plays a critical role in higher education, workforce training and continuing education as students increasingly turn to online courses for certifications and university degrees. This gap is accentuated by the COVID-19 pandemic as many schools remain closed to reduce virus transmission and students are increasingly required to attend classes via remote learning platforms.

**Telehealth:** Telehealth and other virtual care services are an important component of health care delivery, especially where health care services – particularly specialists – are less available, such as in rural communities. Telehealth access has enabled care delivery during the COVID-19 pandemic to allow individuals to remain at home while maintaining continued access to health care services. Through increased remote access to health care providers and improved digital literacy skills, residents can continue to receive critical care virtually while coronavirus transmission remains a concern. An analysis by FAIR Health found that remote services insurance claims in April 2020 rose more than 8,000 percent from prior year, demonstrating a significant increase in the uptake of telehealth.<sup>14</sup> Telehealth has helped many providers remain financially solvent during the emergency, due to relatively steady provider services and patient volume. One study found that in May, telehealth services made up 14 percent of all visits, up from 1 percent in mid-March.<sup>15</sup>

**Commerce:** Commerce is reliant on connectivity, whether for digital commerce, freight logistics, fleet management, automated manufacturing, or asset tracking. With many jurisdictions requiring business closures and issuing stay-at-home orders, the COVID-19 pandemic has heightened this need. Purchasing groceries, medicine and other essentials online reduces crowds and promotes both public health and productivity.



**Agriculture:** Expanded broadband service to rural communities is enabling increased automation and efficiencies in agriculture. Nearly 50 percent of row crops are farmed using guiding technology and broadband services contributes between \$18 and \$23 billion in added productivity in agriculture.<sup>16</sup> Farming with connected technologies can enable better crop yields, efficient business management and sustainable planting.<sup>17</sup>

**Infrastructure Modernization:** As connected infrastructure technologies continue to advance, broadband access is a necessity for digital infrastructure deployment. Broadband allows utilities to remotely monitor and automate electricity, fuel and water distribution systems. Broadband also enables advanced metering that can more accurately track usage, adjust demand and identify water and natural gas pipe leaks. Broadband also allows for asset communications, such as vehicle-to roadway, enabling automation.<sup>18</sup>

**Emergency Response and Public Safety:** The United States has suffered 273 distinct, billion-dollar weather and climate disasters since 1980 with aggregate costs of \$1.79 trillion, increasing in rate and severity in recent years.<sup>19</sup> Broadband can play a critical role to facilitate states' recovery efforts by allowing emergency responders to remain connected and facilitating timely emergency communications and directives to vulnerable populations. As new technologies such as unmanned aerial vehicles are deployed, broadband can assist in search and rescue and remote observation capabilities to improve response while keeping first responders safe.

## **Options for Technology Deployment: How is Broadband Accessed?**

Governors looking to increase access to affordable, reliable broadband in the near term have a range of technology solutions to consider; each with its own trade-offs on cost, speed, reliability, immediacy of deployment and application. Governors may wish to target a mix of technologies that expedite deployment alongside longer-term efforts to expand fixed broadband infrastructure.

### **Wired Technologies**

Wired or "Wireline" broadband technology is transmission technology that sends data through physical connections. Examples of wireline include fiber optic cables, digital subscriber line (DSL) or a cable modem. Wired broadband deployment is generally the preferred long-term strategy to reach state connectivity goals. NGA Vice Chair **Arkansas** Governor Asa Hutchinson, for example, released a state broadband connectivity plan building on previous legislation that enabled government entities and public-private partnerships to provide broadband services. The accompanying state connectivity needs assessment from the Governor's office emphasized wired connections.<sup>20</sup>

- **Phone and Cable Connections**: Broadband is often offered through copper telephone wires already connected to the home (known as a “digital subscriber line” or DSL) or through coaxial cable connections to a home’s TV through the cable wall outlet and computer modem, two technologies that are relatively widely accessible.<sup>21</sup> DSL coverage availability nationally is high, but speeds and costs vary for residential and business users. DSL download speeds range from 5-35 megabits per second (Mbps) whereas cable speeds can be as high as 500 Mbps or, in some cases, even a gigabit per second.<sup>22, 23, 24</sup> Telecommunications industry data point to high cable broadband availability and decreasing per-megabit costs, indicating states may have opportunities to leverage available cable broadband networks to expand broadband use through increased subscriptions.<sup>25</sup>
- **Fiberoptics**: Fiber optic technology converts information from electric signals into light and transmits that information through cables containing hair-thin glass fibers.<sup>26</sup> This enables transmission speeds that can be quicker than DSL or cable and large data-carrying capacities with reduced interference. Fiber technology is thus the focus of many public and private broadband expansion projects and is generally regarded as the long-term technological connectivity solution. As an infrastructure investment, deploying fiber optic technology can carry significant capital costs and regulatory hurdles.<sup>27</sup> The FCC, in its 2020 Broadband Deployment Report, pointed to high year-over-year growth in fiber broadband network availability, becoming available to 6.5 million new homes in 2019.<sup>28</sup> The United States Department of Agriculture has invested heavily in broadband projects focused on fiber deployment through the Rural Development Broadband ReConnect Program.<sup>29</sup>

## **Wireless Technologies**

Wireless broadband connects users to service providers through a mobile or fixed device in a home or business that communicates wirelessly between the customer and provider locations.<sup>30</sup> Wireless options include fixed terrestrial and fixed satellite, mobile and wireless local area networking.<sup>31</sup> These technologies are considered “last mile” (as are cable and DSL wireline technologies) because they connect the user’s location to a fiber optic internet access point.<sup>32</sup> While wireless capabilities bring lower transmission speeds than fiber optics, deployment may be cheaper and faster, particularly in areas with lower population density, as physical connections to homes do not need to be made.

**Mobile Wireless**: This category includes wireless broadband delivery through portable modems or mobile devices that provide internet like smartphones.

- **Wi-Fi Hotspots**: Wireless Fidelity (Wi-Fi) technology connects mobile devices and computers to the internet at short range. Device wireless adapters process and communicate data from and into radio signals that pass through antennae and a router.<sup>33</sup> Local wireless networks located in a public space or building, such as a parking lot or library, can provide a quick internet connection for mobile device



users lacking broadband service at home. While public hotspots are not a sustainable solution to households lacking reliable internet access, hotspot deployment has been a common strategy during the COVID-19 pandemic for state and local governments to deliver quick, temporary internet access to those without.

- **Cellular and 5G:** As mobile technology improves data transmission over time, an increasing number of Americans rely on their smartphones for internet access. The next phase, 5G or fifth generation cellular technology, offers reduced latency and support for a more connected environment (i.e., the “internet of things”). The FCC suggests 5G speeds could be up to 300 Mbps versus 4G at 12 to 36 Mbps.<sup>34</sup>

Small cells, or small radio antennae technology that connect to main fiber lines and extend service to dense user clusters, are key to the 5G rollout.<sup>35, 36</sup> Internet Service Providers (ISPs) offer limited 5G coverage in select markets, but current barriers render the technology a medium to longer-term solution better suited for upgrading connectivity speeds in densely populated areas rather than expanding coverage to new geographies.

Several states have enacted legislation addressing infrastructure regulations like co-location of small cells on other infrastructure (**North Carolina**<sup>37</sup>), local fee limits (**Georgia**<sup>38</sup>), authorizing state agencies to regulate on small rights-of-way related to wireless facilities on state highways (**West Virginia**<sup>39</sup>) and other legislation to facilitate “small wireless facility” deployment and address associated permitting and rights-of-way issues.

**Fixed Wireless:** Fixed Wireless uses radio airwaves to connect the end user to an internet access point like a fiber optic line through receivers located on the user’s premises. Fixed Wireless requires a line of sight to the main access point, potentially limiting range. Because the technology uses radio waves, fixed wireless deployment also requires available spectrum, which is limited and increasingly scarce as the FCC seeks to support 5G networks and the increasing use of Wi-Fi devices.<sup>40</sup>

**Satellite:** Orbiting satellites can provide satellite wireless broadband. While satellite broadband is not bound by a wired tower and can thus offer expansive coverage and faster connection, cost to the provider and customer can be high.<sup>41,42</sup> Satellite technology is common for first responders as an alternative to cell communications. Increasingly, the private sector is deploying innovative new satellite networks with the potential to deliver broad and affordable service. In 2018, the FCC approved SpaceX’s Starlink venture and the company has since launched the first of its 12,000 satellite array.<sup>43</sup> In July 2020, Amazon’s Project Kuiper similarly received FCC approval to launch a global array of 3,236 low earth orbit satellites to connect unserved and underserved populations.<sup>44</sup>

## **Relevant Technological Concepts**

**Middle Mile:** Connects local, “last mile” networks to core broadband networks.<sup>45</sup> Middle mile infrastructure links large scale broadband infrastructure to a provider network service area or local anchor institutions so last mile technologies can connect end users to those local nodes.

**Last Mile:** Connects residences, businesses and other users to the internet backbone – most likely a physical fiber line. As fiber is an expensive and construction-heavy infrastructure project, other technologies like wireless options can help economically bridge the last mile between the main broadband infrastructure and individual user locations.

**Spectrum:** A range of electromagnetic frequencies for wireless communication that the FCC specifically designates for federal or commercial uses like broadcast television, public safety radio systems and the Broadband Radio Service and Educational Broadband Service.<sup>46</sup> The FCC leaves some spectrum open (unlicensed); Wi-Fi routers use spectrum to transmit data and the average person on Wi-Fi is using unlicensed spectrum.

**White space:** An available communications spectrum that currently functions as unused space between television station channels. Television stations are often geographically distanced, and some channels are unused, so new technologies could access this spectrum for broadband connectivity and deliver service. The FCC has previously authorized radio devices to access this spectrum without a license and in February 2020 proposed to modify white space rules including antenna height and transmission power to increase flexibility for devices in rural areas to expand coverage by accessing white space.<sup>47,48</sup>

## **Governors’ Solutions to Expand Broadband**

Recognizing the multiple benefits of connectivity, Governors are implementing a range of policies and programmatic solutions to expand access and increase affordability. While many of these efforts historically focused on expanding wired infrastructure, the growing ubiquity of internet-enabled mobile devices, along with the persistent difficulty of expanding fiber in many rural regions, has made wireless technologies a viable alternative. However, for the highest speeds and most reliable connection, fiber remains the gold standard. The COVID-19 pandemic has created a new urgency for these expansion efforts and, as a result, Governors are increasingly implementing nearer-term solutions to bridge coverage gaps and provide affordable access to those who lack it. However, ubiquitous fiber infrastructure remains a core objective.

Governors have many policy and programmatic tools at their disposal to provide both immediate and long-term access to broadband. The below strategies are marked to symbolize either solutions for service that can be deployed quickly and at lower cost, but may not provide full connectivity or the highest speeds (referred to as “nearer-term solutions”), or longer-term, more permanent solutions for technologies such as fiber





(referred to as “longer-term solutions”), or marked with both symbols for strategies that can be applied towards both objectives.



### Establish Robust, Cross-Cutting Governance Structures



Every state governs, creates, or communicates broadband policy through either a dedicated broadband office or designated staff within other agencies. While the governance structures and organizations vary, at least 20 states and territories have established dedicated broadband offices through executive action or legislation.

In addition to dedicated broadband offices, cross-cutting governance bodies, such as state broadband task forces and working groups, have historically been critical to Governors’ strategies to expand broadband. As of 2019, 27 states have organized or have previously utilized task forces, committees, or advisory councils that incorporate multiple sectors or cut across agencies and jurisdictions.<sup>49</sup> These governing or advisory bodies can create a vital platform to convene stakeholders and foster interagency collaboration. In **Maryland**, for example, the Rural Broadband Task Force includes internet service providers, state agency officials, state legislators, local representatives and broadband-related stakeholders.<sup>50</sup>

Similarly, one of the critical functions of the **Colorado** Broadband Office is to “provide a space and mechanism for all stakeholders, public and private, local, state and federal, to collaborate and address the challenges.”<sup>51</sup> The office also actively coordinates with state agencies, local organizations and stakeholders in the development of the state’s strategic plan. In 2019, **Minnesota** Governor Tim Walz issued an executive order to continue convening the Governor’s Task Force on Broadband, which by order consists of a multi-stakeholder body that issues an annual report, advising the state executive and legislative branches on the needs and barriers to broadband availability and accessibility.<sup>52</sup> Governor leadership has been critical for creating and prioritizing these cross-cutting governance structures and advisory groups.

## Initiate Strategic Partnerships To Kickstart Broadband Investments



As Governors seek to expand broadband coverage many are acting as convenors to forge creative partnerships beyond the formal broadband governance body to advance their connectivity agendas. Governors and state broadband leads can use grant programs and partnerships with state agencies, anchor institutions, the private sector, local government, educators and community organizations to connect their states and leverage relationships, resources and expertise to overcome obstacles.

In **North Carolina** Governor Roy Cooper created a Task Force on Connecting North Carolina with the Governor's Office, state agencies and industry partners, availing the state's broadband expansion campaign to outside expertise, funding streams, relationship networks and technical assistance capacity.<sup>53</sup> Through this multi-pronged approach, North Carolina has increased short-term internet access (Wi-Fi hotspots, Wi-Fi-enabled buses),<sup>54</sup> identified long-term coverage priorities (speed tests),<sup>55,56</sup> engaged a wider set of stakeholders to understand diverse needs (farmer listening sessions,<sup>57</sup> telehealth feasibility studies,<sup>58</sup> equity nonprofit partnerships, homework gap assessments and digital literacy workshops<sup>59</sup>), and built local capacity (community broadband strategy development).<sup>60</sup> This engagement improved the state's broadband coverage as connectivity increased 44 percent between 2014 and 2019.<sup>61</sup>

Other states have invested in local community capacity to drive broadband expansion through grants, technical assistance and locally-led governance structures. The **Indiana** Office of Community & Rural Affairs administers a Broadband Readiness Planning Grant to help communities assess their connectivity status and assets and execute a clear broadband deployment vision.<sup>62,63</sup> In **Vermont**, Governor Phil Scott signed legislation creating a Department of Public Service (DPS) Rural Broadband Technical Assistance Specialist role to provide technical assistance to Communications Union Districts (CUDs) – a conglomeration of towns building communications infrastructure as a joint municipality – and other groups like local units of government and cooperatives by updating broadband maps, assisting with state applications and connecting localities with ISPs.<sup>64,65,66,67</sup> In **Maine**, local communities may partner to create a regional municipal utility district for broadband,<sup>68</sup> and **New Hampshire** Governor Chris Sununu signed legislation authorizing municipalities and counties to issue bonds for publicly-owned broadband infrastructure after soliciting providers for coverage data and proposals to create public-private partnerships to reach unserved areas.<sup>69</sup>

States are also leveraging private partnerships to deliver rapid broadband connectivity during the coronavirus public health emergency. In April 2020, **Vermont** Gov. Scott and the DPS announced a partnership with Microsoft and a local provider and IT service to provide public Wi-Fi hotspots to towns identified by the state's mapping tool as part of the Microsoft Airband Initiative.<sup>70</sup> The **New Mexico** Department of Information Technology released a *State of New Mexico Broadband Strategic Plan and Rural Broadband Assessment* identifying critical broadband coverage needs and highlighting a gap in service for tribal and rural areas. The report identified a need for additional support



for tribal and local governments to apply for funding.<sup>71</sup> To fill the identified coverage gaps, New Mexico is leveraging millions in state-funded projects for fiber-to-the-home including \$2.1 million for unserved rural Sierra County residents, businesses and critical community facilities in conjunction with a \$6.1 million award from the USDA ReConnect program for a partnership between Sacred Winds Communications Telesolutions and Sierra Electric Cooperative,<sup>72</sup> \$2.9 million in an Inter-Governmental Agreement to the Pueblo of Cochiti with funds released through executive order by Governor Lujan Grisham,<sup>73</sup> and \$3 million for a broadband capital outlay to the Navajo Nation.<sup>74,75,76</sup>

---

### **Leverage Anchor Institutions To Provide Rapid Community Internet Service**



Historically, community anchor institutions (such as schools, libraries, medical facilities and government buildings) have served as critical connection points for last mile fiber development to communities. During COVID-19, these anchor institutions have also taken on the role of providing wireless connections through a combination of innovative services. Public libraries across the country have expanded Wi-Fi signals to reach outside of the building to cover surrounding parking lots and established mobile hotspot lending programs.<sup>77</sup> School districts have also played a critical role in connecting students for remote learning by distributing mobile hotspots to homes, as well as equipping school buses with mobile hotspots and deploying buses in underserved communities.

In **South Carolina**, the state Department of Education has procured additional mobile hotspots, deployed hundreds of internet-equipped school buses to communities, and directed school districts to identify students that lack internet access, including providing internet access for 100,000 households under the federal poverty line.<sup>78</sup> In **Maine**, Governor Janet Mills acquired nearly 15,000 hotspot devices for all students who lacked connectivity at home, as identified through school surveys. For this procurement, Maine utilized a combination of philanthropic contributions and federal funds, including \$9.3 million allocated through the CARES Act.<sup>79</sup>

**Missouri** Governor Mike Parson announced in July 2020 that \$10 million of the state's CARES Act allocated funds would be dedicated to reimbursing school districts for expanded internet connectivity efforts, which is estimated to allow for internet connections for 250,000 students.<sup>80</sup> Similarly, a portion of the **Tennessee** coronavirus relief fund has been dedicated to the Tennessee Emergency Broadband Fund, which offers grants for a variety of projects including public Wi-Fi access at community locations and on public buses.<sup>81</sup> Through the program, \$61 million in grants has been awarded across 61 projects, including \$40 million to electric co-ops to provide rural broadband services.<sup>82</sup>

Importantly, anchor institutions can also support longer-term broadband deployment. In 2019, **Illinois** Governor JB Pritzker launched a \$400 million grant program, Connect Illinois, to support broadband infrastructure projects, including a \$20 million capital program to repair and expand the state's Illinois Century Network, which connects schools, libraries and government facilities, and the Connected Communities grants for strategic broadband planning.<sup>83,84</sup> In 2020, the first cohort of Connected Communities grant recipients included four school districts, two community-based organizations, two local governments, two county-level organizations and two economic development groups.<sup>85</sup>

The **New Mexico** Public Education Department has issued a request for quotes from local ISPs for cost savings through volume pricing of broadband solutions for approximately 12,000 unserved student residential addresses. The resulting quotes will be displayed in a custom online portal for participating public schools and school districts to access when procuring future services.<sup>86</sup>

---

### **Leverage Existing Infrastructure Projects With Dig-Once Coordination**



Over the past decades, states have increasingly explored the potential for broadband infrastructure deployment cost reductions by enhancing agency coordination and coordination with stakeholders in the planning, construction and maintenance of infrastructure assets. Broadly, this coordination is referred to as a dig-once policy, with the central premise that during the construction or repair of a road or a water pipe, agencies can leverage rights-of-way to simultaneously install conduit or run fiber at a lower cost.<sup>87</sup> As of 2019, 11 states have adopted dig-once policy frameworks or similar policies.<sup>88</sup>

Public rights-of-way, particularly along highways and other transportation infrastructure, are commonly used to accommodate public utilities, and can be a useful tool for states and local governments to expand broadband infrastructure. In **Utah**, the state Department of Transportation has played a key role in expanding broadband infrastructure across the state by coordinating the lease of rights-of-way along state highways in public private partnerships with internet service providers.<sup>89</sup> Between 2000 and 2018, Utah DOT has deployed or facilitated the deployment of nearly 2,800 miles of fiber infrastructure.

**California** couples state infrastructure investments with wired broadband deployment by requiring state-led highway construction projects to communicate with broadband deployment companies when projects present opportunities for accompanying broadband conduit installation. The state's Governor-appointed broadband council convenes stakeholders from multiple agencies, including the California State Transportation Authority, to identify and collaborate on deployment opportunities.<sup>90</sup>

The **Indiana** Department of Transportation's broadband corridors program seeks to advance broadband infrastructure deployment by allowing private broadband providers to pay a fee or

enter a resource sharing agreement to occupy a public right-of-way and install fiber along an interstate or highway.<sup>91</sup>

In May 2019, **North Carolina** Governor Roy Cooper signed an executive order requiring the North Carolina Department of Transportation to work with the Department of Information Technology's Broadband Infrastructure Office to develop a new policy focused on open trench excavations along state-maintained, non-National Highway System roads.<sup>92</sup>

---

### **Leverage Electric Utilities' Infrastructure And Services To Facilitate Broadband Network Deployments**



Governors can work with broadband service providers and utilities, including investor-owned utilities and rural electric cooperatives, through public-private partnerships and grant programs to extend broadband coverage by using existing infrastructure backbones and rights-of-way, leasing capacity to other providers and reaching unserved rural cooperative customer bases. The high cost of connecting individual customers in areas with geographic challenges or low population density can impede universal broadband goals, but some states deliver broadband to challenging areas by diversifying their partnerships and broadening broadband service provider eligibilities.

Several states are looking to these partners to boost broadband availability. Borne out of Governor calls for broadband investment and coverage expansion, **Alabama**,<sup>93</sup> **Arizona**,<sup>94,95</sup> **North Carolina**,<sup>96</sup> **Tennessee**,<sup>97</sup> **Virginia**<sup>98</sup> and **West Virginia**<sup>99</sup> passed legislation including various provisions allowing electric utilities and cooperatives to deploy broadband through their services or existing fiber networks and easements or work with an affiliate or local providers in their service areas, and to operate and maintain their own broadband infrastructure.

The states also targeted expanding delivery through co-location requirements and designating state grant funds to subsidize commercial telecommunications provider broadband efforts. States including **Vermont**,<sup>100</sup> **Virginia** (see case study below), and **West Virginia**<sup>101</sup> have used legislation and state grant programs to conduct feasibility studies to consider the capacity for electric utilities and cooperatives in their state to provide broadband service.

In July 2020, **Mississippi** Governor Tate Reeves signed the Mississippi Electric Cooperatives Broadband COVID-19 Act creating a grant program and designating \$65 million of the state's CARES Act relief funds for grants to electric cooperatives (and \$10 million for other broadband providers) for broadband access expansion as a necessary response to the COVID-19 public health emergency.<sup>102,103</sup> Estimates expected this investment to make broadband service available to more than 35,000 rural homes.<sup>104</sup>

While states are incorporating electric utilities into their broadband deployment strategies, a policy study by R Street notably found several potential challenges to broadband delivery through electric cooperatives, including impacts to market competition and future investment from cost-advantaged utilities using their own infrastructure to deliver broadband and impacts to electric ratepayers as cooperatives price services to cover broadband infrastructure investments. Potential best practices to avoid these impacts could include instituting governance and accounting measures to limit local electric service monopolies from cross-subsidizing broadband services and ensuring the charging of fair market price affiliate asset use fees.<sup>105</sup>

### **Case Study: Virginia Engages Utility and Cooperative Providers**

In Virginia, Governor Ralph Northam announced a goal to achieve universal broadband coverage in the state by 2028. The Virginia Commonwealth Connect broadband report encouraged substantive engagement and cooperation among the Commonwealth's broadband team, the Commonwealth and local governments and both private and public regional authority, cooperative and investor-owned utility broadband providers.<sup>106</sup> The 2019 report highlights the role cooperatives and other private sector partners can play in last mile broadband deployment, laying fiber networks, leasing fiber capacity to local governments and multiplying state grant program funds through their own investments.<sup>107</sup>

Commonwealth legislation helped increase broadband partnerships with cooperatives and utilities:

- The Grid Transformation and Security Act of 2018 codified tax credits for the Commonwealth of Virginia's investor-owned utilities (IOU), Dominion Energy and Appalachian Power, to make investments in smart metering and grid modernization technologies, and directed the utilities to examine possible avenues to extend broadband coverage to the unserved using their infrastructure. Investor-owned electric utilities would work with the State Communications Commission (SCC) to evaluate options to provide broadband or lease capacity to a commercial provider, identify any necessary infrastructure improvements and report findings to the SCC, the Governor, the Broadband Advisory Council and relevant House and Senate committee chairs.<sup>108</sup>
- The 2019 HB 2691 declared broadband access to be in the public interest and required the State Communications Commission to create pilot programs for Dominion and Appalachian Power to either provide or make broadband capacity available to non-governmental ISPs to offer to unserved areas, and authorizing the utilities to own or lease broadband capacity equipment (the ISP must offer the actual broadband service; the IOU may not). The utilities were authorized to recover pilot program costs (proposals capped at \$60 million) through customer rate adjustments.<sup>109</sup>
- In 2020, Gov. Northam signed legislation allowing easements for electric and communications facilities to be accessed for broadband delivery.<sup>110</sup> Electric cooperative representative groups supported the adjustment as it would make electric cooperatives' participation in broadband expansion efforts easier by reducing costs and allowing cooperatives to access electric easements to deploy broadband instead of having to obtain their own easements.<sup>111</sup>

Virginia's executive and legislative branches and broadband program administrators worked together to involve electric utilities in broadband expansion. The Governor set a Commonwealth-wide broadband coverage goal, the legislature authorized practical steps and the Commonwealth broadband program planned partnerships accordingly. As a result, in 2020 Dominion Energy and Appalachian Power each announced initiatives to deliver fiber broadband to unserved areas by providing the middle mile fiber network and partnering with an ISP (Dominion partnered with a rural electric cooperative) to target customers in a specific county.<sup>112,113</sup>

### Coordinate and Expand Affordability Programs



The cost of broadband services can be a significant barrier to increasing statewide adoption. Beyond monthly service rates, factors contributing to affordability can also include contract length, activation or installation fees and equipment costs. In response to the COVID-19 pandemic, 16 states ordered the suspension of utility shutoffs as a result of nonpayment to include telecom services.<sup>114</sup> Further, many internet service providers have enacted new or improved low-cost service options for low-income households, those recently unemployed, or discounted services for essential workers.<sup>115</sup>

Several state broadband offices have compiled and maintained lists of the affordable service plans that are relevant for their residents, as well as the federal resources, including the FCC's Lifeline program, which provides a monthly discount for low-income households.<sup>116</sup> For example, **Wisconsin's** Public Service Commission has published a list of provider plans with their associated service maps, locations of public Wi-Fi spots, and the information for a dedicated helpline.<sup>117</sup> Similarly, the **Colorado** Broadband Office maintains lists of affordable or discounted broadband resources for the general public, schools and libraries, health care providers and first responders.<sup>118</sup> In **North Carolina**, the Department of Information Technology's Broadband Infrastructure Office convenes a group of digital equity leaders and inclusion-focused organizations to share best practices and coordinate on strategies to close the state's digital divide, including promoting existing low-cost programs.<sup>119</sup> Several states have also incorporated affordability components into their broadband grant scoring and award process.

---

### Deploy Innovative Procurement Strategies



In a time where state budgets are increasingly strained, it is critical to take advantage of innovative procurement solutions to reduce barriers for new project deployments and to identify cost effective providers. States are interested in shortening the purchasing process, building partnerships with suppliers, and perhaps most importantly, keeping costs down. Strategies to streamline the procurement processes can include cooperative purchasing, umbrella contracts and bulk purchasing agreements, among others.

In **North Dakota**, Governor Doug Burgum has aggressively embraced the digital era and connected nearly the entire state to broadband. One program overcame privacy challenges to map students lacking internet access in their households. A network of state agencies, utilities and the Governor's office identified 2,000 rural households lacking connectivity. The state acted as a procurement vehicle, having network service providers bid on these selected locations to increase competition and affordability. This cooperative agreement, along with a strong commitment to connecting rural areas, has ensured that 99.8 percent of North Dakota's rural students have internet access in their households.<sup>120</sup>

**Michigan** operates the MiDEAL program to allow localities, schools and hospitals to purchase goods and services at reduced rates while cutting time soliciting bids.<sup>121</sup> Existing contracts include commercial broadband services for local governments. Many states include broadband in bulk purchasing agreements to leverage economies of scale. Alternatively, states may enter umbrella contracts with retailers to set a general negotiating framework for future procurement. Generally, these agreements are more flexible and responsive to current conditions, while reducing the need for immediate contracts. **New York** has an umbrella contract for certain hardware and software devices, expediting procurement on competitively priced information technology.<sup>122</sup>

### Improve Broadband Coverage Maps



The collection of data on current broadband availability and provided service speeds is critical in prioritizing expansion efforts. This data is currently collected and mapped by the FCC, but as the FCC acknowledges, the data collected twice per year from broadband providers via Form 477 is imperfect, only capturing service provided at a census-block level and only establishing where minimum speeds are being met. To create a more accurate representation of the level of broadband service being provided, states have developed alternative mapping strategies that provide more data at higher granularity. In 2018, **Georgia** launched the Georgia Broadband Deployment Initiative to provide residential level broadband availability data. The Georgia initiative's 2020 map showed significantly more areas of the state lacked broadband coverage than had been identified by the 2019 FCC Form 477 map, by setting the threshold for labeling each census-block as served or underserved at 80 percent of the locations (residences or businesses) having speeds of 25 Mbps down and 3 Mbps up.<sup>123</sup>

Figure 1. Georgia Broadband Availability, Comparing FCC Data to State Map

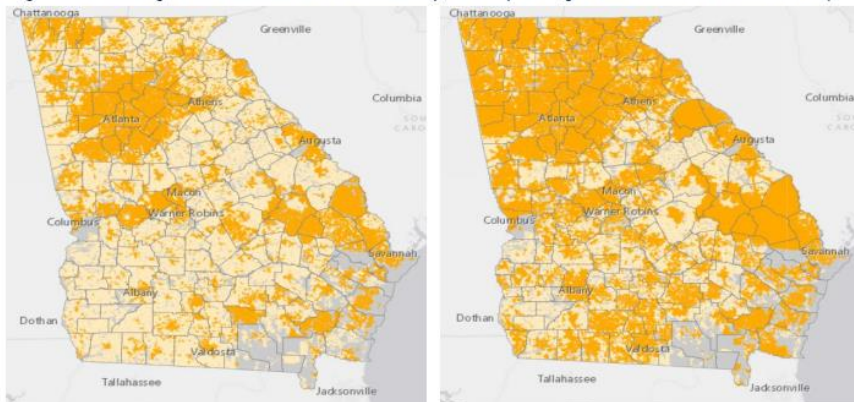

Georgia map on the left, FCC map on the right, “served” locations in the darker color and “unserved” locations in the lighter color.

Importantly, the success of mapping efforts can hinge on the level of engagement of the internet provider companies that operate in each state. Insufficient engagement or participation can directly result in incomplete maps. In **Minnesota**, the Office of Broadband Development maintains a state-wide service map by collecting data from service providers, which are reviewed and verified by a third party.<sup>124</sup> Alternatively, several states have also created surveys to bolster their availability data and better target expansion efforts. The state of **Washington** recently released a speed test survey tool and has received more than 18,000 responses, showing 92.3 percent of respondents have broadband access.<sup>125</sup> In a partnership between the **North Carolina** Department of Information Technology's Broadband Infrastructure Office and the Friday Institute for Educational Innovation at North Carolina State University, the state conducts an internet access and speed test survey, which has to date received more than 36,000 responses.<sup>126</sup>

These data mapping efforts have been repeatedly used to challenge the FCC Form 477 in applications for additional federal support (*see Appendix*). Acknowledging the need to update the FCC broadband data collection process, in 2018 Congress directed NTIA, in coordination with the FCC, to incorporate mapping data that is being collected by states, other federal agencies and third-party organizations to create a new National Broadband Availability Map. As of July 2020, 22 states are participating with NTIA's updated mapping process.<sup>127</sup>

More accurate maps of the availability, quality and cost of broadband services in each state and territory provide Governors with an important tool to better inform residents and measure the progress of state programs. In response to the COVID-19 pandemic, many of these mapping efforts have also incorporated interactive layers displaying publicly available Wi-Fi hotspot locations.

---

### Identify Funding and Financing Sources for Broadband Deployment



Broadband expansion is expensive and inadequate funds or the lack of economic payback for broadband expansion in some situations remains a barrier. Many states have dedicated state funding mechanisms to address middle mile and last mile broadband expansion. These are often supplemented by federal programs that offer grants to states, municipalities and other entities to accelerate broadband deployment, including FCC programs such as the Universal Service Fund or Rural Digital Opportunity Fund, which are targeted toward specific regions like underserved census blocks or rural areas.

The FCC is not the only major federal funder for broadband expansion and further delineation of funding can be seen in the *Appendix*. Many federal agencies understandably focus on specific policy priorities, therefore segmenting resource allocations. This can create gaps in broadband coverage, especially if funds have

restricted uses. Governors may consider how to use multiple funding sources to leverage economies of scale in deployments, for example coordinating funding for broadband to anchor institutions such as schools with funding for extending last mile connectivity to nearby homes and businesses. To maximize federal funds, state participants at NGA's roundtable highlighted the need for flexible, unrestricted state funding through programs such as federal block grants.

Apart from leveraging federal funds, states have their own funding programs, albeit of lesser scope than federal programs. State funding mechanisms include supplemental universal service fund spending, grants to individuals, businesses, or communities, loans or loan guarantee programs and more. As of 2018, 42 states operate their own versions of universal service funds to supplement federal programs.<sup>128</sup> These funds support a variety of needs including services for deaf and hard of hearing individuals, phone devices and equipment, discounts for high-cost installations, and additional funding for the Lifeline program. States spent nearly \$82 million of USF funding in 2017 to support high cost corridors, low-income assistance, rural health care, schools and libraries.

Finally, states are taking different approaches to increase broadband services. The Commonwealth of **Kentucky** is building a 3,000-mile fiber optic middle mile network to connect every county. The program is state owned and expects to lease half of the fiber cables to private companies to offset costs. While the program does not directly improve end users' internet speeds, it will allow public and private ISPs to more easily connect communities to last mile infrastructure.<sup>129</sup> **Indiana** Governor Eric Holcomb announced \$100 million in funding for last mile service as part of the Next Level Connections program. The program is making grant awards of up to \$5 million and recently awarded \$51 million to 50 projects, while also receiving \$53 million in matching funds from ISP applicants.<sup>130</sup> **Illinois** and **New York** are respectively offering one-time commitments of \$400 million and \$500 million for broadband deployment.<sup>131, 132</sup> Notably, the size of these investments is not financially feasible for every state.

Other states spread out more limited state funding over several years. **Minnesota** has appropriated \$110 million for broadband expansion through its Border to Border Grant Program in \$20 million annual allocations.<sup>133</sup> **North Carolina** similarly offers \$15 million annually over the next 10 years through state funds.<sup>134</sup> **Vermont** is offering \$10.8 million in state grants and loans, targeting rural customers, providing funding for alternative providers and building technical assistance capacity.<sup>135</sup> Both upfront and long-term investments advance state efforts to expand affordable broadband coverage. However, additional funding will be required to fully connect each household, which has become an increasingly urgent objective during the COVID-19 pandemic.

### ***CARES Act State Spending Uses***

On March 27, 2020, the Coronavirus Aid, Relief, and Economic Security Act (CARES Act) was signed into law, bringing with it more than \$2 trillion in economic stimulus. The CARES Act included funding provisions for individuals, the private sector and state



and local governments. States are rapidly determining how to spend funding allocations, working toward an end-of-year allocation deadline. Where allowable under U.S. Treasury guidelines, broadband investments have been a priority for multiple states, such as investments to upgrade distanced learning capacity. Many states are funding device purchases for students and teachers and Wi-Fi routers in school buses, prioritizing rural and low-income individuals. The below table describes selected examples of how Governors are deploying CARES Act funding on broadband. Since new allocations continue to be made, this table should be considered a snapshot in time.

**Select State Investments in Broadband Leveraging CARES Act Funding**

**Alabama:** Allocated up to \$300 million for expenditures related to remote learning, \$53 million for remote work, and established a broadband working group to guide CARES Act funding toward relevant broadband projects.<sup>136</sup>

**Arkansas:** Allocated \$10 million to seven telecommunications companies to expand broadband access in rural communities.<sup>137</sup>

**Delaware:** \$20 million for broadband infrastructure, with \$13 million directed toward wireless vouchers and devices for underserved families with school-age children.<sup>138</sup>

**Idaho:** \$50 million for broadband infrastructure – directing funding to private companies to make broadband investments.<sup>139</sup>

**Iowa:** \$85 million for expanding telework, telehealth and remote learning through broadband expansion. Opened \$50 million in CARES act funding to award grants for broadband infrastructure expansion. The program is run through the existing Empower Rural Iowa Broadband Grant Program.<sup>140</sup>

**Kansas:** Allocated more than \$130 million toward coronavirus response. While broadband expansion is not the entirety of these relief funds, it is an eligible activity. One grant supports telework and telehealth needs, while a separate grant funds remote learning needs for low-income households.<sup>141</sup>

**Michigan:** \$25 million to support connectivity for school children and their families. Fund to cover several device-purchasing options to support remote learning expansion in the next 3-6 months. More incentives are made towards communities with higher poverty rates.<sup>142</sup>

**Mississippi:** Allocating \$275 million in federal funding toward broadband – \$65 million to state’s electric co-ops for rural broadband expansion. Program matches federal funding with broadband expansion costs borne by the utilities. Pandemic Response Broadband Availability Act set up a \$50 million special fund in state treasury to grants for school districts in compliance with CARES Act. \$150 million is allocated to school districts to purchase laptops for students and boost distanced learning capabilities.<sup>143</sup>

## ***Governor Strategies to Expand Affordable Broadband Access***

**Missouri:** \$10 million for remote K-12 learning – reimburses school districts for increasing student connectivity and campus Wi-Fi networks. \$10 million for higher ed distanced learning needs. \$5.25 million for telehealth, with plans to install more than 12,500 hotspots. \$20 million to reimburse broadband providers. \$2.5 million for library resources that will support hotspots and Wi-Fi access for telehealth and higher ed resources. Additional funding available for broadband technical assistance requests.<sup>144</sup>

**Nevada:** \$50 million for K-12 schools to create alternative intensive instruction. This program targets students “likely to develop the largest deficits in education attainment” from a lack of in-school learning. Students include English as Second Language students, low-income students, those with low test scores or at low performing schools, among others.<sup>145</sup>

**New Hampshire:** \$50 million for broadband – seeking applications for enhancing remote learning, remote work and telehealth. Again, this application is on an accelerated time scale, with the application open for two weeks and notifications two weeks later. All projects must be completed by December 15.<sup>146</sup>

**New Mexico:** \$1.5 million in CARES Act funds for broadband technical assistance for local and tribal governments and other groups to advance broadband deployment and help communities prepare for Federal funding opportunities.<sup>147,148,149</sup> Partnered with the N.M. Public Education Department and others to identify, promote and support broadband solutions for K-12 students that reside in unserved or underserved areas of the state. As of June 2020, this collaborative has used CARES Act funding to purchase and distribute 700 residential hotspots (Navajo Nation), thousands of Chromebooks and numerous other fixed and mobile hotspot devices for Tribal communities.<sup>150</sup>

**North Carolina:** \$672,000 for telework capabilities. Gov. Cooper signed legislation to provide \$56 million for distanced learning activities including installing Wi-Fi routers in school buses, providing home internet access points, purchases computers for K-12 students and teachers, as well as providing funding for cybersecurity infrastructure.<sup>151</sup>

**North Dakota:** \$23.9 million for telework, \$17 million for cybersecurity and \$26.8 million for digital government services.<sup>152</sup>

**Puerto Rico:** \$40 million for telework program, \$40 million for telemedicine program.<sup>153</sup>

**South Carolina:** Allocating \$50 million to broadband programs. One program targets all students to provide mobile hotspots in 100,000 qualifying households. Funding will also support identified areas of need and a mapping program.<sup>154</sup>

**South Dakota:** Governor Kristi Noem announced CARES Act funds would support the K-12 Connect program to provide internet service at no cost to eligible K-12 students in their homes for the remainder of the 2020-21 school year.<sup>155</sup>

**Tennessee:** Governor Bill Lee announced \$61 million to be allocated for emergency broadband funds to support telehealth, remote learning and telework services. The state allocated \$60 million of general funds towards broadband and this new funding will potentially support projects that were previously denied due to a lack of program funding.<sup>156</sup>

**Vermont:** \$17.5 million to a new COVID-Response Accelerated Broadband Connectivity Program, supplements lifeline program, telehealth services, remote learning or telework needs, with \$2.5 million segmented out to separately address telecommunications services, telehealth, connected Communications Union Districts.<sup>157</sup>

**Virginia:** \$30 million in CARES Act funding for broadband projects. Localities are encouraged to apply with projects that “creatively address the digital divide, including projects that address infrastructure or the cost of broadband services.”<sup>158</sup>

**West Virginia:** \$50 million for general broadband development.<sup>159</sup>

**Wyoming:** Coordination between Governor Mark Gordon and the state Business Council identified several broadband expansion projects and deployed \$55 million of CARES Act funding.<sup>160</sup>

---

## **Remaining Challenges**

While this white paper offers many solutions to broadband expansion challenges, there are additional remaining hurdles Governors may need to address. First, many federal funding sources are program specific, constraining state or local spending to specific priorities, regions or end uses, such as rural health care or education. These funds designated for one end use can often have broader benefits (for example, Wi-Fi for educational purposes can be used for telehealth visits) so it can be important to consider the full range of benefits of individual investments. These single end-uses may also be limiting, as a small incremental cost to expand the scope of a program for greater community benefit may be unallowable. Ensuring cross-sector linkages are made can help to ensure the better utilization of limited funds.

State broadband expansion also faces financial challenges that may bar potential internet providers access to the market and reduce competition. In rural areas, low population densities may make new investment uneconomic for traditional providers. In low income urban areas, there may be a lack of incentive for new entrants to compete, resulting in monopolies or duopolies that keep prices high. Governors can consider how investments may reduce these barriers for new and alternative providers to enter those markets. Further, Governors may wish to explore any policy or regulatory barriers that prohibit new market entrants from competing.

## **Conclusion**

Expanding broadband access and increasing affordability have been top policy priorities for Governors. As the necessity of internet access has rapidly grown over the past three decades, states have established and modified a variety of best practices to increase the deployment of broadband infrastructure. The COVID-19 pandemic has added an immediate urgency to provide internet access so that people can continue to work, attend school, and access critical services virtually while abiding by telework requirements, required distance learning, and stay at home orders necessitated by public health guidance. This rapid mobilization has taxed systems and agencies, creating a tension between the need to balance short-term fixes with longer-term investments and more permanent infrastructure projects. The strategies laid out in this paper demonstrate how Governors are tackling these challenges and the emerging best practices for expanding affordable broadband access.

## **Acknowledgements**

The National Governors Association Center for Best Practices (NGA) and this report's authors thank the state officials and other experts who attended the virtual Experts' Roundtable in May 2020 that informed this paper. NGA appreciates the additional experts and NGA Partners who offered insights and feedback. NGA also thanks Western Governors University (WGU) for its support of the roundtable and publication of this paper. To support affordable broadband access, WGU has announced the Online Access Scholarship Program to cover the cost of high-speed internet access and provide devices to students who need and cannot afford them. For more information visit: [WGU.edu](http://WGU.edu).

## **Authors**

National Governors Association Center for Best Practices

- ❖ Matthew Rogotzke - Policy Analyst
- ❖ Timothy Schoonhoven - Policy Analyst
- ❖ Jake Varn - Policy Analyst
- ❖ Dan Lauf - Program Director

## **Recommended Citation Format**

Rogotzke, M., Schoonhoven, T., Varn, J., & Lauf, D. (2020, October). *Governor Strategies to Expand Affordable Broadband Access*. Washington, D.C.: National Governors Association Center for Best Practices.

Appendix: Federal Broadband Programs and Funding Resources

Agency/Branch	Program Name	Program Description	Total Funding	Individual Funding Awards	Additional Funding through the CARES Act
U.S. Department of Agriculture (USDA) – Rural Utilities Service (RUS)	<a href="#">Reconnect Loan and Grant</a>	Provides loans and grants to cover broadband construction costs in eligible rural areas	\$550 million	Loan up to \$50 million, with 2 percent interest. Combo loan/grant \$25 million each. Grants available up to \$25 million with a 25 percent match	\$100 million
USDA – RUS	<a href="#">Rural Broadband Access Loan and Loan Guarantee</a>	Offers loans to construct facilities and acquire equipment for providing broadband service in eligible rural areas.	NA – Not currently funded	Loans made and authorized through the Farm Bill	N/A
USDA – RUS	<a href="#">Community Connect</a>	Funds broadband deployment in communities lacking economic viability with private providers	NA – Not currently funded	Grants were made up to \$1.5 million with a 15 percent match requirement.	N/A
USDA – RUS	<a href="#">Telecommunications Infrastructure Loans and Loan Guarantees</a>	Provides financing support to expand telephone and broadband access in rural areas with fewer than 5,000 people	\$690 million	Cost-of-Money loans available directly, as well as loan guarantees to private lenders to connect local borrowers	N/A
USDA – RUS	<a href="#">Distance Learning and Telemedicine</a>	Helps remote learning and telehealth telecommunications needs in rural areas	\$50 million	Grants are awarded with a 15 percent match requirement. Awards range from \$50,000 to \$1 million	\$25 million

Agency/Branch	Program Name	Program Description	Total Funding	Individual Funding Awards	Additional Funding through the CARES Act
Federal Communications Commission (FCC) – Universal Service Fund (USF)	<a href="#">Connect America Fund – High Cost</a>	The program funds broadband service in unserved and underserved areas by funding ISP connection plans	The phase II auction funded nearly \$1.5 billion over 10 years	103 bidders are splitting the awards to serve more than 700,000 locations in 45 states	N/A
FCC – USF	<a href="#">Lifeline – Low Income</a>	Assists low income individuals to help pay phone and connections charges	\$2.385 billion	Allocates \$9.25 per household in broadband support per month	N/A
FCC – USF	<a href="#">Schools and Libraries – E-Rate</a>	Eligible schools and libraries receive discounts on costs of telecommunications services	\$4.15 billion in FY2019	Discounts range from 20 to 90 percent, based on the poverty level of the school, with rural schools and libraries potentially receiving higher discounts	N/A
FCC – USF	<a href="#">Rural Health Care</a>	Reduces costs for rural health care providers to make telecommunication services more competitive to urban provider costs	Funding cap for FY2020 is \$605 million	Eligible providers may receive a 65 percent flat discount on telecommunications services	\$42.19 million as well as \$200 million for telehealth in general
FCC	<a href="#">Rural Digital Opportunity Fund</a>	Targets completely unserved areas to be followed by partially served areas by funding ISP broadband deployment in eligible census blocks	\$20.4 billion over 10 years	The first auction to award up to \$16 billion for unserved areas was held in October 2020	N/A
FCC	<a href="#">5G Fund for Rural America</a>	Deploying 5G services to eligible rural communities	\$9 billion	Currently seeking public comment on how to distribute project funds	N/A

Agency/Branch	Program Name	Program Description	Total Funding	Individual Funding Awards	Additional Funding through the CARES Act
U.S. Department of Commerce– National Telecommunications and Information Administration (NTIA)	<a href="#">BroadbandUSA</a>	Not funding focused, provides technical assistance, resource guides and broadband maps. NTIA also hosts a state broadband working group	N/A	N/A	N/A
U.S. Department of Education	<a href="#">Elementary and Secondary Relief Fund</a>	K-12 emergency funding to respond to COVID crisis growing need for remote learning	N/A	States are awarded funds in proportion to the Elementary and Secondary Education Act (ESEA)	\$13.2 billion
U.S. Department of Education	<a href="#">Higher Education Emergency Relief Fund</a>	Reimburses students and teachers for technology needs	N/A	The funds will be awarded to higher education institutions on a formula outlined by Congress	\$14.25 billion
U.S. Department of Education	<a href="#">Governor’s Emergency Relief Fund</a>	Block grants for educational entities most impacted by COVID. The grants are largely flexible to cover current student and school needs.	NA	Funds are awarded to Governors’ offices 60 percent based on relative school-aged population and 40 percent based on children counted under ESEA	\$3 billion
U.S. Department of Education	<a href="#">Title I, Part A</a>	Provides financial assistance to schools with high percentages of low-income students.	\$16.31 billion	States are awarded funds on a formula basis	
U.S. Department of Education	<a href="#">Title IV, Part A</a>	Improves technology accessibility and digital literacy for all students	\$1.21 billion	States are awarded funds on a formula basis	

Agency/Branch	Program Name	Program Description	Total Funding	Individual Funding Awards	Additional Funding through the CARES Act
U.S. Department of Housing and Urban Development	<a href="#">Community Development Block Grants</a>	Block grants are provided annually on a formula to states for primarily low- and moderate-income assistance projects. Funds may be used to install broadband infrastructure to benefit eligible communities.	\$3.4 billion	While funds are not exclusively focused on broadband infrastructure, states may flexibly allocate funding toward broadband. West Virginia has utilized these funds toward broadband expansion.	\$5 billion
U.S. Department of Transportation	<a href="#">INFRA Grants</a>	Provides Federal financial assistance to highway and freight projects of national or regional significance, encourages applicants to include the deployment of innovative technology and expanded access to broadband.	\$906 million	Large projects of at least \$25 million, small project grant awards of \$5 million for both construction and project development.	N/A

---

## Endnotes

- <sup>1</sup> Federal Communications Commission (FCC). (2020, April 24). *2020 Broadband Deployment Report*. Federal Communications Commission. <https://docs.fcc.gov/public/attachments/FCC-20-50A1.pdf>
- <sup>2</sup> U.S. Census Bureau. (2020, July). *Week 12 Household Pulse Survey: July 16 - July 21*. U.S. Census Bureau. <https://www.census.gov/data/tables/2020/demo/hhp/hhp12.html>
- <sup>3</sup> Busby, J., Tanberk, J., & BroadbandNow Team. (2020, February). *FCC Reports Broadband Unavailable to 21.3 Million Americans, BroadbandNow Study Indicates 42 Million Do Not Have Access*. BroadbandNow Research. <https://broadbandnow.com/research/fcc-underestimates-unserved-by-50-percent>
- <sup>4</sup> Tanberk, J. (2020, July 28). *The State of Broadband in America, Q2 2020*. BroadbandNow Research. <https://broadbandnow.com/research/q2-broadband-report-2020>
- <sup>5</sup> Ibid.
- <sup>6</sup> Broadband Commission for Sustainable Development. (2019, September). *The State of Broadband: Broadband as a Foundation for Sustainable Development*. International Telecommunications Commission. [https://www.itu.int/dms\\_pub/itu-s/opb/pol/S-POL-BROADBAND.20-2019-PDF-E.pdf](https://www.itu.int/dms_pub/itu-s/opb/pol/S-POL-BROADBAND.20-2019-PDF-E.pdf)
- <sup>7</sup> Anderson, M. (2019, June 13). *Mobile Technology and Home Broadband*. Pew Research Center. <https://www.pewresearch.org/internet/2019/06/13/mobile-technology-and-home-broadband-2019/>
- <sup>8</sup> U.S. Department of Commerce, National Telecommunications and Information Administration. (2020, June). *Internet Use Survey*. U.S. Department of Commerce, National Telecommunications and Information Administration. <https://www.ntia.doc.gov/data/digital-nation-data-explorer#sel=noNeedInterestMainReason&demo=&pc=prop&disp=chart>
- <sup>9</sup> U.S. Department of Commerce, National Telecommunications and Information Administration. (2020, June). *Internet Use Survey*. U.S. Department of Commerce, National Telecommunications and Information Administration. <https://www.ntia.gov/data/digital-nation-data-explorer#sel=homeInternetUser&demo=race&pc=prop&disp=chart>
- <sup>10</sup> Pew Research Center. (2019, June). *Internet/Broadband Fact Sheet (Surveys conducted 2000-2019)*. Pew Research Center. <https://www.pewresearch.org/internet/fact-sheet/internet-broadband/>
- <sup>11</sup> Lee, E. (2008). *State Efforts to Expand Broadband Access*. National Governors Association. <https://www.nga.org/wp-content/uploads/2020/06/0805BROADBANDACCESS.pdf>
- <sup>12</sup> Guyot, K., & Sawhill, I. (2020, April). *Telecommuting will likely continue long after the pandemic*. The Brookings Institution. <https://www.brookings.edu/blog/up-front/2020/04/06/telecommuting-will-likely-continue-long-after-the-pandemic/>
- <sup>13</sup> U.S. Congress Joint Economic Committee. (2017, September). *America's Digital Divide*. U.S. Congress Joint Economic Committee. [https://www.jec.senate.gov/public/\\_cache/files/ff7b3d0b-bc00-4498-9f9d-3e56ef95088f/the-digital-divide-.pdf](https://www.jec.senate.gov/public/_cache/files/ff7b3d0b-bc00-4498-9f9d-3e56ef95088f/the-digital-divide-.pdf)
- <sup>14</sup> FAIR Health. (2020, April). *Monthly Telehealth Regional Tracker*. FAIR Health. <https://s3.amazonaws.com/media2.fairhealth.org/infographic/telehealth/apr-2020-national-telehealth.pdf>
- <sup>15</sup> Mehrotra, A., Chermew, M., Linetsky, D., Hatch, H., and Cutler, D. (2020, June 25). *The Impact of the COVID-19 Pandemic on Outpatient Visits: Practices Are Adapting to the New Normal*. The Commonwealth Fund. <https://doi.org/10.26099/2v5t-9v63>
- <sup>16</sup> United States Department of Agriculture. (2019, April). *A Case for Rural Broadband*. United States Department of Agriculture. <https://www.usda.gov/sites/default/files/documents/case-for-rural-broadband.pdf>
- <sup>17</sup> Stephens, E. C., Martin, G., van Wijk, M., Timsina, J., & Snow, V. (2020). *Editorial: Impacts of COVID-19 on agricultural and food systems worldwide and on progress to the sustainable development goals. Agricultural systems*, 183, 102873. <https://doi.org/10.1016/j.agsy.2020.102873>
- <sup>18</sup> Utility Broadband Alliance. (2020). *Power Grids, Meet Strong Networks*. Utility Broadband Alliance. <https://www.ubba.com/power-grids-meet-strong-networks/>
- <sup>19</sup> National Oceanic and Atmospheric Administration. (2020). *Billion-Dollar Weather and Climate Disasters: Overview*. National Oceanic and Atmospheric Administration. <https://www.ncdc.noaa.gov/billions/>

- <sup>20</sup> Office of Arkansas Governor Asa Hutchinson. (2019, May 15). *Arkansas State Broadband Plan*. Office of Arkansas Governor Asa Hutchinson. [https://governor.arkansas.gov/images/uploads/Arkansas\\_State\\_Broadband\\_Plan\\_Final\\_5.15.19\\_.pdf](https://governor.arkansas.gov/images/uploads/Arkansas_State_Broadband_Plan_Final_5.15.19_.pdf)
- <sup>21</sup> FCC. (2020). *Getting Broadband Q&A*. FCC. <https://www.fcc.gov/consumers/guides/getting-broadband-qa>
- <sup>22</sup> Cooper, T. (2020). *DSL vs Cable vs Fiber: Comparing Internet Options*. BroadbandNow. <https://broadbandnow.com/guides/dsl-vs-cable-vs-fiber>
- <sup>23</sup> FCC. (2014). *Types of Broadband Connections*. FCC. <https://www.fcc.gov/general/types-broadband-connections>
- <sup>24</sup> NCTA. (2020). *Tracking Cable's Top Internet Speeds* [Data Graphic]. NCTA. <https://www.ncta.com/sites/default/files/inline-images/Artboard%201051518.png>
- <sup>25</sup> NCTA. (2020). *Industry Data* [Infographic]. NCTA. [https://www.ncta.com/industry-data?field\\_industry\\_data\\_categories\\_target\\_id\[84\]=84](https://www.ncta.com/industry-data?field_industry_data_categories_target_id[84]=84)
- <sup>26</sup> FCC. (2020). *Getting Broadband Q&A*. FCC. <https://www.fcc.gov/consumers/guides/getting-broadband-qa>
- <sup>27</sup> Cooper, T. (2020). *Fiber-Optic Internet in the United States*. BroadbandNow. <https://broadbandnow.com/Fiber>
- <sup>28</sup> FCC. (2020, April 24). *2020 Broadband Deployment Report*. FCC. <https://docs.fcc.gov/public/attachments/FCC-20-50A1.pdf>
- <sup>29</sup> USDA Rural Development. (2020). *ReConnect Program*. USDA. <https://www.usda.gov/reconnect>
- <sup>30</sup> FCC. (2014). *Types of Broadband Connections*. FCC. <https://www.fcc.gov/general/types-broadband-connections>
- <sup>31</sup> National Research Council. (2002). *Broadband: Bringing Home the Bits*. Washington, DC: The National Academies Press. <https://doi.org/10.17226/10235>
- <sup>32</sup> Iowa Communications Network. (2020). *What are the Wireless Broadband Technologies?* Broadbandmatters.com. <https://broadbandmatters.com/what-are-wireless-broadband-technologies>
- <sup>33</sup> Ibid.
- <sup>34</sup> FCC. (2020). *5G FAQs*. FCC. <https://www.fcc.gov/5g-faqs>
- <sup>35</sup> NextCentury Cities. (2017, February 2). *Small Cells – What You Need to Know*. NextCentury Cities. <https://nextcenturycities.org/small-cells-fact-sheet/#:~:text=Small%20cells%20are%20a%20new,previously%20unserved%20or%20underserved%20areas>
- <sup>36</sup> City of San Jose. (2020). *Broadband Strategy and Small Cell Deployment*. City of San Jose. <https://www.sanjoseca.gov/your-government/department-directory/office-of-the-city-manager/civic-innovation/broadband-strategy-and-small-cell-deployment-5147>
- <sup>37</sup> General Assembly of North Carolina. (2019). *SB355: An Act to Clarify, Consolidate, and Reorganize the Land-Use Regulatory Laws of the State*. State of North Carolina. <https://www.ncleg.gov/Sessions/2019/Bills/Senate/PDF/S355v6.pdf>
- <sup>38</sup> Georgia General Assembly. (2019-2020). *SB66: Streamlining Wireless Facilities and Antennas Act*. State of Georgia. <http://www.legis.ga.gov/legislation/en-US/Display/20192020/SB/66>
- <sup>39</sup> West Virginia Legislature. (2020). *Enrolled Committee Substitute for SB 364*. State of West Virginia. [http://www.wvlegislature.gov/Bill\\_Text\\_HTML/2020\\_SESSIONS/RS/bills/SB364%20SUB1%20ENR.pdf](http://www.wvlegislature.gov/Bill_Text_HTML/2020_SESSIONS/RS/bills/SB364%20SUB1%20ENR.pdf)
- <sup>40</sup> Cooper, T. (2020). *Fixed Wireless Internet in the USA*. BroadbandNow. <https://broadbandnow.com/Fixed-Wireless>
- <sup>41</sup> FCC. (2014). *Types of Broadband Connections*. FCC. <https://www.fcc.gov/general/types-broadband-connections>
- <sup>42</sup> National Research Council. (2002). *Broadband: Bringing Home the Bits*. Washington, DC: The National Academies Press. <https://doi.org/10.17226/10235>
- <sup>43</sup> FCC. (2018, March 29). *FCC Authorizes SpaceX to Provide Broadband Satellite Services*. FCC. <https://www.fcc.gov/document/fcc-authorizes-spacex-provide-broadband-satellite-services>
- <sup>44</sup> FCC. (2020, July 30). *FCC Authorizes Kuiper Satellite Constellation*. FCC. <https://www.fcc.gov/document/fcc-authorizes-kuiper-satellite-constellation>
- <sup>45</sup> Massachusetts Broadband Institute. (2020). *Middle Mile Program*. Massachusetts Broadband Institute. <https://broadband.masstech.org/middle-mile-program>



- <sup>46</sup> FCC. (2020). *Broadband Radio Service & Education Broadband Service*. FCC. <https://www.fcc.gov/wireless/bureau-divisions/broadband-division/broadband-radio-service-education-broadband-service>
- <sup>47</sup> FCC. (2020). *White Space*. FCC. <https://www.fcc.gov/general/white-space>
- <sup>48</sup> FCC. (2020, February 7). *FCC Notice of Proposed Rulemaking, Unlicensed White Space Device Operations in the Television Bands*. FCC. <https://docs.fcc.gov/public/attachments/DOC-362361A1.pdf>
- <sup>49</sup> Pew Charitable Trusts. (2019, July). *No One Approach Fits All States in Efforts to Expand Broadband Access*. Pew Charitable Trusts. [https://www.pewtrusts.org/-/media/assets/2019/07/bri\\_agencies\\_v1.pdf](https://www.pewtrusts.org/-/media/assets/2019/07/bri_agencies_v1.pdf)
- <sup>50</sup> Maryland Rural Broadband Task Force. (2017, May 26). *Governor Signs Connecting Rural Maryland Act of 2017*. Rural Maryland Council. <https://rural.maryland.gov/2017/05/26/governor-signs-connecting-rural-maryland-act-of-2017/>
- <sup>51</sup> Colorado Broadband Office. (2020). *Policy*. State of Colorado. <https://broadband.co.gov/resources/policy/>
- <sup>52</sup> Minnesota Department of Employment and Economic Development, Office of Broadband Development. (2020). *Broadband Task Force*. State of Minnesota. <https://mn.gov/deed/programs-services/broadband/task-force/>
- <sup>53</sup> Office of North Carolina Governor Roy Cooper. (2019, May 14). *EO No. 91*. State of North Carolina. [https://files.nc.gov/governor/documents/files/EO91\\_BROADBAND-TASK\\_FORCE\\_ON\\_CONNECTING\\_NC.pdf](https://files.nc.gov/governor/documents/files/EO91_BROADBAND-TASK_FORCE_ON_CONNECTING_NC.pdf)
- <sup>54</sup> North Carolina Department of Information Technology (NCDIT) Broadband Information Office. (2019, May 21) *State Agencies Partner to Improve Broadband Access in Rural Communities*. State of North Carolina. <https://www.ncbroadband.gov/news/press-releases/2019/05/21/state-agencies-partner-improve-broadband-access-rural-communities>
- <sup>55</sup> NCDIT Broadband Infrastructure Office. (2020, July 15). *North Carolina State IT Department and Broadband Office Announce Broadband Survey and Encourage Statewide Participation*. State of North Carolina. <https://www.ncbroadband.gov/news/press-releases/2020/07/15/north-carolina-state-it-department-and-broadband-office-announce>
- <sup>56</sup> NC OneMap. (2020). *North Carolina Broadband Mapping Applications*. State of North Carolina. <https://www.nconemap.gov/pages/broadband>
- <sup>57</sup> NC Cooperative Extension. (2020, January 27). *Internet Connectivity Survey for NC Farmers*. North Carolina State University. <https://lee.ces.ncsu.edu/2020/01/internet-connectivity-survey-for-nc-farmers-3/>
- <sup>58</sup> NCDIT Broadband Information Office. (2020, July 24). *Feasibility Study Recommends Ways to Increase Access to Broadband, Telehealth Services in Western NC*. State of North Carolina. <https://www.ncbroadband.gov/news/press-releases/2020/07/24/feasibility-study-recommends-ways-increase-access-broadband>
- <sup>59</sup> NCDIT State Broadband Office. (2020, January 3). *Expanded Broadband Access, Worked to Close the Digital Divide in 2019*. State of North Carolina. <https://it.nc.gov/news/press-releases/2020/01/03/state-broadband-office-expanded-broadband-access-worked-close-digital>
- <sup>60</sup> NCDIT Broadband Information Office. (2018, March 28). *State Broadband Office Releases Community Playbook*. State of North Carolina. <https://www.ncbroadband.gov/news/press-releases/2018/03/28/state-broadband-office-releases-community-playbook>
- <sup>61</sup> Sural, J. (2020, January 29). *Testimony of North Carolina Broadband Information Office Director Jeff Sural*. United States House of Representatives Committee on Energy and Commerce, Subcommittee on Communications and Technology. <https://docs.house.gov/meetings/IF/IF16/20200129/110416/HHRG-116-IF16-Wstate-SuralJ-20200129.pdf>
- <sup>62</sup> Indiana Office of Community & Rural Affairs. (2019, July). *Rural Broadband*. State of Indiana. <https://www.in.gov/ocra/2336.htm>
- <sup>63</sup> Indiana Office of Community & Rural Affairs. (2020). *CDBG Planning Grant Minimum Plan Requirements*. State of Indiana. *Broadband Readiness Plan*. Indiana Office of Community & Rural Affairs. [https://www.in.gov/ocra/files/Broadband\\_Readiness\\_Plan.pdf](https://www.in.gov/ocra/files/Broadband_Readiness_Plan.pdf)
- <sup>64</sup> Vermont General Assembly. (2020, November). *Title 30: Public Service Chapter 82: Communications Unions Districts*. State of Vermont. <https://legislature.vermont.gov/statutes/chapter/30/082>
- <sup>65</sup> Vermont Department of Public Service. (2020, November). *Rural Broadband Technical Assistance*. State of Vermont. <https://publicservice.vermont.gov/content/rural-broadband-technical-assistance>

- <sup>66</sup> Vermont Department of Public Service. (2020, November). *Vermont Communications Union Districts*. State of Vermont. <https://publicservice.vermont.gov/content/vermont-communications-union-districts>
- <sup>67</sup> Vermont General Assembly. (2020). *H.513. An act relating to broadband deployment throughout Vermont*. State of Vermont. <https://legislature.vermont.gov/Documents/2020/Docs/ACTS/ACT079/ACT079%20As%20Enacted.pdf>
- <sup>68</sup> Maine Legislature. (2015). *HP 632, LD912: An Act To Allow the Establishment of Regional Municipal Utility Districts To Support Telecommunications, Broadband Communications and Energy Infrastructure*. State of Maine. [https://legislature.maine.gov/legis/bills/bills\\_127th/billtexts/HP063201.asp](https://legislature.maine.gov/legis/bills/bills_127th/billtexts/HP063201.asp)
- <sup>69</sup> New Hampshire Legislature. (2018). *SB 170: An act relative to the authority of towns to issue bonds for the expansion of broadband infrastructure*. State of New Hampshire. [https://legiscan.com/NH/text/SB170/id/1789739/New\\_Hampshire-2018-SB170-Enrolled.html](https://legiscan.com/NH/text/SB170/id/1789739/New_Hampshire-2018-SB170-Enrolled.html)
- <sup>70</sup> Office of Vermont Governor Phil Scott. (2020, April 16). *Businesses Partnering with the State of Vermont to Address Rural Broadband Gap*. State of Vermont. <https://governor.vermont.gov/press-release/businesses-partnering-state-vermont-address-rural-broadband-gap>
- <sup>71</sup> New Mexico Department of Information Technology. (2020, June). *State of New Mexico Broadband Strategic Plan and Rural Broadband Assessment*. State of New Mexico. [https://www.doit.state.nm.us/broadband/reports/nmbbp\\_strategic20200616Rev2Final.pdf](https://www.doit.state.nm.us/broadband/reports/nmbbp_strategic20200616Rev2Final.pdf)
- <sup>72</sup> Senator Tom Udall. (2020, October 21). *N.M. Delegation Hails Over \$20 Million in Funding to Connect Over 2800 Rural Homes, Farms and Businesses with Broadband Internet Across Seven Counties*. Office of Senator Tom Udall. <https://www.tomudall.senate.gov/news/press-releases/nm-delegation-hails-over-20-million-in-funding-to-connect-over-2800-rural-homes-farms-and-businesses-with-broadband-internet-across-seven-counties>
- <sup>73</sup> New Mexico Department of Information Technology. (2020, June 3). *N.M. awards Cochiti Pueblo \$2.9 million for broadband*. State of New Mexico. <https://www.newmexico.gov/2020/06/03/n-m-awards-cochiti-pueblo-2-9-million-for-broadband/>
- <sup>74</sup> New Mexico Public Education Department. (2020, June 25). *Internet Connectivity Concerns on Tribal Lands: Guidance Document*. State of New Mexico. [https://webnew.ped.state.nm.us/wp-content/uploads/2020/04/Revised-Tribal-Guidance-Document\\_FINAL\\_6.25.2020.pdf](https://webnew.ped.state.nm.us/wp-content/uploads/2020/04/Revised-Tribal-Guidance-Document_FINAL_6.25.2020.pdf)
- <sup>75</sup> New Mexico Department of Information Technology. (2020, October 9). *New Mexico Department of Information Technology Awarded \$1.5 Million in CARES Act Recovery Funding*. State of New Mexico. [https://www.doit.state.nm.us/docs/news/newsreleases/2020-10-09\\_cares\\_broadband\\_grant.pdf](https://www.doit.state.nm.us/docs/news/newsreleases/2020-10-09_cares_broadband_grant.pdf)
- <sup>76</sup> The Navajo Nation Office of the President and Vice President. (2020, March 12). *Nation's leaders work together to secure \$14.7 million in Capital Outlay Funds in New Mexico*. Navajo Nation. [https://www.navajonnsn.gov/News%20Releases/OPVP/2020/Mar/FOR%20IMMEDIATE%20RELEASE%20-%20Nation%20leaders%20work%20together%20to%20secure\\$14.7%20million%20in%20Capital%20Outlay%20Funds%20in%20New%20Mexico.pdf](https://www.navajonnsn.gov/News%20Releases/OPVP/2020/Mar/FOR%20IMMEDIATE%20RELEASE%20-%20Nation%20leaders%20work%20together%20to%20secure$14.7%20million%20in%20Capital%20Outlay%20Funds%20in%20New%20Mexico.pdf)
- <sup>77</sup> Ohio Library Council. (2020, April 16). *Ohio's Public Libraries Improve, Expand Services During COVID-19 Pandemic*. Ohio Library Council. <http://olc.org/blog/2020/04/16/ohios-public-libraries-improve-expand-services-during-covid-19-pandemic/>
- <sup>78</sup> State of South Carolina, Department of Education. (2020, July 7). *Memorandum: Update on Act 142 on Free Hotspots and Service Plans*. State of South Carolina. <https://ed.sc.gov/newsroom/school-district-memoranda-archive/update-on-act-142-on-free-hotspots-and-service-plans/update-on-act-142-on-free-hotspots-and-service-plans-memo/>
- <sup>79</sup> Office of Maine Governor Janet T. Mills. (2020, May 15). *Mills Administration Secures Wi-Fi & Learning Devices for 100 Percent of Maine Students Reporting a Need In Face of COVID-19's Impacts on Schools*. State of Maine. <https://www.maine.gov/governor/mills/news/mills-administration-secures-wifi-learning-devices-100-percent-maine-students-reporting-need>
- <sup>80</sup> Williams, K. (2020, July 6). *Missouri K-12 education receives roughly \$55M of CARES Act funding*. KSHB. <https://www.kshb.com/news/coronavirus/missouri-k-12-education-receives-roughly-55m-of-cares-act-funding>
- <sup>81</sup> Tennessee Department of Economic & Community Development. (2020). *Tennessee Emergency Broadband Fund*. State of Tennessee. <https://www.tn.gov/ecd/rural-development/tennessee-broadband-grant-initiative/tennessee-emergency-broadband-fund.html>

- <sup>82</sup> Scott, T. (2020, August). *Tennessee Electric Co-ops Awarded \$40 Million in Broadband Grants*. Tennessee Electric Cooperative Association. <https://www.tnelectric.org/2020/08/21/tennessee-electric-co-ops-awarded-40-million-in-broadband-grants/>
- <sup>83</sup> Illinois Department of Commerce and Economic Opportunity. (2020). *Connect Illinois*. State of Illinois. <https://www2.illinois.gov/dceo/ConnectIllinois/Pages/default.aspx>
- <sup>84</sup> Illinois Department of Commerce and Economic Opportunity. (2020, June). *Connect Illinois 2020 Round 1 Projects*. State of Illinois. <https://www2.illinois.gov/dceo/ConnectIllinois/Documents/Connect%20Illinois%20Rd%201%20Project%20Summaries.pdf>
- <sup>85</sup> Illinois Department of Commerce and Economic Opportunity. (2020). *Connect Illinois, Illinois Connected Communities*. State of Illinois. <https://www2.illinois.gov/dceo/ConnectIllinois/Pages/ConnectedCommunities.aspx>
- <sup>86</sup> New Mexico Department of Information Technology. (2020, September). *Internet Services Provider Request for Quotes*. New Mexico Department of Information Technology.
- <sup>87</sup> United States Department of Transportation, Federal Highways Administration. (2013, October). *Dig Once Policy Brief: Minimizing Excavation Through Coordination*. FHWA. [https://www.fhwa.dot.gov/policy/otps/policy\\_brief\\_dig\\_once.pdf](https://www.fhwa.dot.gov/policy/otps/policy_brief_dig_once.pdf)
- <sup>88</sup> Cooper, T. (2019, August). *Dig Once: The Digital Divide Solution Congress Squandered And Policy That Could Save \$126 Billion On Broadband Deployment*. BroadbandNow. <https://broadbandnow.com/report/dig-once-digital-divide/>
- <sup>89</sup> Utah Legislature. (1999, February). *S.B. 150, Relocation of Utilities in Highway Rights-of-way Task Force*. State of Utah. <https://le.utah.gov/~1999/html/doc/sbillhtm/SB0150.htm>
- <sup>90</sup> Caltrans. (2020). *Wired Broadband Facilities on State Highway Right of Way*. State of California. <https://dot.ca.gov/programs/design/wired-broadband>
- <sup>91</sup> Indiana Department of Transportation. (2020). *Broadband Corridors*. State of Indiana. <https://www.in.gov/indot/3685.htm>
- <sup>92</sup> Office of North Carolina Governor Cooper. (2020, May 14). *Governor Cooper Launches Initiative to Increase Broadband Connectivity, Executive Order No. 91*. State of North Carolina. <https://governor.nc.gov/news/governor-cooper-launches-initiative-increase-broadband-connectivity>
- <sup>93</sup> Alabama Legislature. (2019, May 23). *HB400: Telecommunications, Broadband Using Electric Easement Accessibility Act*. State of Alabama. <https://legiscan.com/AL/text/HB400/id/2049810/Alabama-2019-HB400-Enrolled.pdf>
- <sup>94</sup> Office of Arizona Governor Doug Ducey. (2020, January 13). *New: Governor Ducey Announces Major New Investments in Rural Broadband*. State of Arizona. <https://azgovernor.gov/governor/news/2020/01/new-governor-ducey-announces-major-new-investments-rural-broadband>
- <sup>95</sup> State of Arizona Senate. (2020). SB 1460. Fifty-fourth legislature. <https://www.azleg.gov/legtext/54leg/2R/laws/0084.pdf>
- <sup>96</sup> North Carolina Electric Cooperatives. (2020). *Rural Broadband*. North Carolina Electric Cooperatives. <https://www.ncelectriccooperatives.com/in-the-community/broadband/>
- <sup>97</sup> State of Tennessee Legislature. (2017, May 3). *Senate Bill No. 1215: Tennessee Broadband Accessibility Act*. LegiScan. <https://legiscan.com/TN/text/HB0529/id/1801985/Tennessee-2017-HB0529-Chaptered.pdf>
- <sup>98</sup> General Assembly of Virginia. (2020, April 10). *S. 794, Chapter 1131*. Code of Virginia. <https://leg1.state.va.us/cgi-bin/legp504.exe?201+ful+CHAP1131>
- <sup>99</sup> West Virginia Legislature. (2020, March 7). *House Bill 4619*. Code of West Virginia. [http://www.wvlegislature.gov/Bill\\_Status/bills\\_text.cfm?billdoc=HB4619%20SUB%20ENR.htm&yr=2020&sesstype=RS&billtype=B&houseorig=H&i=4619](http://www.wvlegislature.gov/Bill_Status/bills_text.cfm?billdoc=HB4619%20SUB%20ENR.htm&yr=2020&sesstype=RS&billtype=B&houseorig=H&i=4619)
- <sup>100</sup> General Assembly of the State of Vermont. (2019). *H. 513: An act relating to broadband deployment throughout Vermont*. State of Vermont. <https://legislature.vermont.gov/Documents/2020/Docs/ACTS/ACT079/ACT079%20As%20Enacted.pdf>
- <sup>101</sup> West Virginia Legislature. (2020, March 7). *House Bill 4619*. Code of West Virginia. [http://www.wvlegislature.gov/Bill\\_Status/bills\\_text.cfm?billdoc=HB4619%20SUB%20ENR.htm&yr=2020&sesstype=RS&billtype=B&houseorig=H&i=4619](http://www.wvlegislature.gov/Bill_Status/bills_text.cfm?billdoc=HB4619%20SUB%20ENR.htm&yr=2020&sesstype=RS&billtype=B&houseorig=H&i=4619)

- <sup>102</sup> Mississippi Legislature. (2020). *SB 3046*. Mississippi Senate. <http://billstatus.ls.state.ms.us/documents/2020/pdf/SB/3000-3099/SB3046SG.pdf>
- <sup>103</sup> Mississippi Public Service Commission. (2020). *Broadband COVID-19 Grant Program*. State of Mississippi. <https://www.mpus.ms.gov/covid19grant>
- <sup>104</sup> North East Mississippi Electric Power Association. (2020, July 28). *Mississippi Electric Cooperatives Broadband COVID-19 Grant Program*. NEMEPA. <https://www.nemepa.org/broadband-update/>
- <sup>105</sup> Kavulla, T. and Lacey, F. (2019, September). *Financial And Governance Protections For Electric Cooperatives, R Street Policy Study No. 181*. R Street. <https://www.rstreet.org/wp-content/uploads/2019/09/Final-No.-181.pdf>
- <sup>106</sup> Commonwealth Connect. (2020). *Report on Commonwealth Connect 2.0: Governor Northam's 2020 Plan to Connect Virginia*. State of Virginia. <https://www.commonwealthconnect.virginia.gov/sites/default/files/CIT%20Documents/Commonwealth%20Connect%20Report.pdf>
- <sup>107</sup> Commonwealth Connect. (2019). *Report on Commonwealth Connect: Governor Northam's Plan to Connect Virginia*. State of Virginia. <https://rga.lis.virginia.gov/Published/2019/RD109/PDF>
- <sup>108</sup> Virginia's Legislative Information System. (2018, March 9). *S. 966: An Act...relating to electric utility regulation; grid modernization; energy efficiency programs*. State of Virginia. <https://lis.virginia.gov/cgi-bin/legp604.exe?181+ful+CHAP0296>
- <sup>109</sup> Virginia's Legislative Information System. (2019, March 19). *H 2691: An Act to amend the Code of Virginia by adding a section numbered 56-585.1:8, relating to a pilot program for the provision of broadband capacity to unserved areas of the Commonwealth by certain electric utilities*. State of Virginia. <https://lis.virginia.gov/cgi-bin/legp604.exe?191+ful+CHAP0619>
- <sup>110</sup> General Assembly of Virginia. (2020, April 4). *S. 794: An Act to amend and reenact § 55.1-306 of the Code of Virginia and to amend the Code of Virginia by adding a section numbered 55.1-306.1, relating to utility easements; broadband and other communications services*. State of Virginia. <https://leg1.state.va.us/cgi-bin/legp504.exe?201+ful+CHAP1131>
- <sup>111</sup> Cash, C. (2020, June 9). *New Virginia Easement Law Reduces Costs, Delays for Co-op Broadband*. Cooperative.com. <https://www.cooperative.com/news/pages/new-virginia-law-aids-electric-co-ops-building-broadband.aspx>
- <sup>112</sup> Dominion Energy. (2020, February 21). *Thousands of Rural Virginians Could Get Broadband Access through Dominion Energy, Prince George Electric Cooperative Partnership*. Dominion Energy. <https://investors.dominionenergy.com/news/press-release-details/2020/Thousands-of-Rural-Virginians-Could-Get-Broadband-Access-through-Dominion-Energy-Prince-George-Electric-Cooperative-Partnership/default.aspx>
- <sup>113</sup> Appalachian Power. (2020, May 14). *Virginia SCC approves Appalachian Power's broadband pilot program*. Appalachian Power. <https://www.appalachianpower.com/info/news/viewRelease.aspx?releaseID=5556>
- <sup>114</sup> National Energy Assistance Directors' Association. (August 20, 2020). *Summary of State Utility Shut-off Moratoriums due to COVID-19*. NEADA. <https://neada.org/utilityshutoffsuspensions/>
- <sup>115</sup> National Digital Inclusion Alliance. (2020). *Free and Low-Cost Internet Plans*. NDIA. <https://www.digitalinclusion.org/free-low-cost-internet-plans/>
- <sup>116</sup> Federal Communications Commission. (August 12, 2020). *Lifeline Support for Affordable Communications*. FCC. <https://www.fcc.gov/consumers/guides/lifeline-support-affordable-communications>
- <sup>117</sup> Wisconsin Public Service Commission. (2020). *Internet Resources for Wisconsin Residents during Public Health Emergency*. State of Wisconsin. <https://psc.wi.gov/Pages/Programs/BroadbandEmergencyInternetResources.aspx>
- <sup>118</sup> Colorado Broadband Office. (2020, July 15). *COVID-19 Broadband Resources and Updates*. State of Colorado. <https://broadband.co.gov/covid-19/>
- <sup>119</sup> North Carolina Department of Information Technology, Broadband Infrastructure Office. (2020). *Digital Equity Collaborative*. State of North Carolina. <https://www.ncbroadband.gov/digital-divide/digital-equity-collaborative>
- <sup>120</sup> Digital Bridge K-12. (2020). *How North Dakota Bridged the Home Access Gap*. EducationSuperhighway. <https://digitalbridgek12.org/states/how-north-dakota-bridged-the-home-access-gap/>

- <sup>121</sup> Michigan Department of Technology, Management and Budget. (2020). *State of Michigan MIDEAL*. State of Michigan. [https://www.michigan.gov/dtmb/0,5552,7-358-82550\\_85753---,00.html](https://www.michigan.gov/dtmb/0,5552,7-358-82550_85753---,00.html)
- <sup>122</sup> New York State Office of Government Services. (2020, October 19). *Information Technology Umbrella Contract – (Distributor Based Statewide)*. State of New York. <https://online.ogs.ny.gov/purchase/snt/awardnotes/7360022876can.htm>
- <sup>123</sup> Georgia Broadband Deployment Initiative. (2020, June). *FCC vs GBDI Broadband Comparison*. State of Georgia. <https://broadband.georgia.gov/fcc-vs-gbdi-broadband-comparison>
- <sup>124</sup> Minnesota Office of Broadband Deployment. (2020). *Maps and Data*. State of Minnesota. <https://mn.gov/deed/programs-services/broadband/maps/>
- <sup>125</sup> Washington State Department of Commerce. (2020). *Broadband Access and Speed Survey*. State of Washington. <https://www.commerce.wa.gov/building-infrastructure/washington-statewide-broadband-act/speedtestsurvey/>
- <sup>126</sup> North Carolina Department of Information Technology, Broadband Infrastructure Office. (2020). *North Carolina Broadband Survey*. State of North Carolina. <https://www.ncbroadband.gov/broadband-nc/north-carolina-broadband-survey>
- <sup>127</sup> U.S. Department of Commerce, National Telecommunications Information Administration. (2020, July 23). *National Broadband Availability Map Adds Indiana and Georgia*. Department of Commerce. <https://www.ntia.doc.gov/blog/2020/national-broadband-availability-map-adds-indiana-and-georgia>
- <sup>128</sup> Lichtenberg, S. (2019, April). *State Universal Service Funds 2018: Updating the Numbers*. National Regulatory Research Institute. <https://pubs.naruc.org/pub/3EA33142-00AE-EBB0-0F97-C5B0A24F755A>
- <sup>129</sup> Kentucky Wired, Kentucky Communications Network Authority. (2020). *Kentucky Wired*. Kentucky Communications Network Authority. <https://kentuckywired.kv.gov/Pages/index.aspx>
- <sup>130</sup> Office of Indiana Governor Eric J. Holcomb. (2020, September 3). *Gov. Holcomb announces more than \$51 million for broadband expansion*. State of Indiana. <https://calendar.in.gov/site/gov/event/gov-holcomb-announces-more-than-51-million-for-broadband-expansion/>
- <sup>131</sup> Illinois Department of Commerce and Economic Opportunity. (2020). *Connect Illinois: Broadband Grants*. State of Illinois. <https://www2.illinois.gov/dceo/ConnectIllinois/Pages/BroadbandGrants.aspx>
- <sup>132</sup> Rachfal, C. (2020, April). *State Broadband Initiatives: Selected State and Local Approaches as Potential Models for Federal Initiatives to Address the Digital Divide*. Congressional Research Service. <https://crsreports.congress.gov/product/pdf/R/R46307>
- <sup>133</sup> Minnesota Department of Employment and Economic Development, Broadband Grant Program. (2020). State of Minnesota. <https://mn.gov/deed/programs-services/broadband/grant-program/>
- <sup>134</sup> North Carolina Department of Information Technology, Broadband Infrastructure Office. (2020). *Growing Rural Economies with Access to Technology (GREAT) Grant Program*. State of North Carolina. <https://www.ncbroadband.gov/grants/great-grant>
- <sup>135</sup> General Assembly of the State of Vermont. (2019). *H. 513: No. 79 An act relating to broadband deployment throughout Vermont*. State of Vermont. <https://legislature.vermont.gov/Documents/2020/Docs/ACTS/ACT079/ACT079%20As%20Enacted.pdf>
- <sup>136</sup> Office of Alabama Governor Kay Ivey. (2020, May 18). *Executive Amendment to Senate Bill 161*. State of Alabama. <https://governor.alabama.gov/assets/2020/05/Executive-Amendment-to-Senate-Bill-161.pdf>
- <sup>137</sup> Office of Arkansas Governor Asa Hutchinson. (2020, August 14). *Leveling the Broadband Playing Field*. State of Arkansas. <https://governor.arkansas.gov/news-media/weekly-address/leveling-the-broadband-playing-field/>
- <sup>138</sup> Office of Delaware Governor John Carney. (2020, August 24). *Governor Carney Announces \$20 Million for Broadband Infrastructure*. State of Delaware. <https://news.delaware.gov/2020/08/24/governor-carney-announces-20-million-for-broadband-infrastructure/>
- <sup>139</sup> Idaho Department of Commerce. (2020, June 29). *Idaho Department of Commerce Opens Applications for Idaho Broadband Grant Program*. State of Idaho. <https://commerce.idaho.gov/press-releases/idaho-department-of-commerce-opens-applications-for-idaho-broadband-grant-program/>
- <sup>140</sup> Iowa Office of the Chief Information Officer. (2020, July 20). *Notice of Funding Availability #003 – Federally-Funded Opportunity*. State of Iowa. <https://ocio.iowa.gov/notice-funding-availability-003-federal-funding-opportunity>
- <sup>141</sup> Kansas Department of Commerce. (2020). *Economic Development & Connectivity*. State of Kansas. <https://www.kansascommerce.gov/covidrelief/>

<sup>142</sup> State of Michigan Legislature. (2020, July 1). *SB 690: An act to make, supplement, and adjust appropriations for various state departments and agencies for the fiscal year ending September 30, 2020; and to provide for the expenditure of the appropriations*. State of Michigan 100<sup>th</sup> Legislature.

<http://www.legislature.mi.gov/documents/2019-2020/publicact/pdf/2020-PA-0123.pdf>

<sup>143</sup> Office of Mississippi Lieutenant Governor Delbert Hosemann. (2020, August 20). *Legislature Champions Expanding High Speed Internet, Uses Relief Funds to Expand Access*. State of Mississippi. <https://ltgovhosemann.ms.gov/legislature-champions-expanding-high-speed-internet-uses-relief-funds-to-expand-access/>

<sup>144</sup> Missouri Department of Economic Development. (2020, July 2). *Governor Parson directs nearly \$50 million in relief funds to aid in broadband expansion and COVID-19 response*. State of Missouri.

<https://ded.mo.gov/content/governor-parson-directs-nearly-50-million-relief-funds-aid-broadband-expansion-and-covid-19>

<sup>145</sup> State of Nevada Legislature. (2020). *AB3*. Nevada Legislature 31<sup>st</sup> Special Session.

<https://www.leg.state.nv.us/App/NELIS/REL/31st2020Special/Bill/7127/Overview>

<sup>146</sup> Office of New Hampshire Governor Chris Sununu. (2020, June 18). *State seeks bids for Connecting NH – Emergency Broadband Expansion Program*. State of New Hampshire.

<https://www.governor.nh.gov/news-and-media/state-seeks-bids-connecting-nh-emergency-broadband-expansion-program>

<sup>147</sup> New Mexico Department of Information Technology. (2020, June). *State of New Mexico Broadband Strategic Plan and Rural Broadband Assessment*. State of New Mexico.

[https://www.doit.state.nm.us/broadband/reports/nmbbp\\_strategic20200616Rev2Final.pdf](https://www.doit.state.nm.us/broadband/reports/nmbbp_strategic20200616Rev2Final.pdf)

<sup>148</sup> State of New Mexico Public Education Department. (2020, June 25). *Internet Connectivity Concerns on Tribal Lands: Guidance Document*. State of New Mexico. [https://webnew.ped.state.nm.us/wp-content/uploads/2020/04/Revised-Tribal-Guidance-Document\\_FINAL\\_6.25.2020.pdf](https://webnew.ped.state.nm.us/wp-content/uploads/2020/04/Revised-Tribal-Guidance-Document_FINAL_6.25.2020.pdf)

<sup>149</sup> New Mexico Department of Information Technology. (2020, October 9). *New Mexico Department of Information Technology Awarded \$1.5 Million in CARES Act Recovery Funding*. State of New Mexico.

[https://www.doit.state.nm.us/docs/news/newsreleases/2020-10-09\\_cares\\_broadband\\_grant.pdf](https://www.doit.state.nm.us/docs/news/newsreleases/2020-10-09_cares_broadband_grant.pdf)

<sup>150</sup> State of New Mexico Public Education Department. (2020, June 25). *Internet Connectivity Concerns on Tribal Lands: Guidance Document*. State of New Mexico. [https://webnew.ped.state.nm.us/wp-content/uploads/2020/04/Revised-Tribal-Guidance-Document\\_FINAL\\_6.25.2020.pdf](https://webnew.ped.state.nm.us/wp-content/uploads/2020/04/Revised-Tribal-Guidance-Document_FINAL_6.25.2020.pdf)

<sup>151</sup> General Assembly of North Carolina. (2020). *HB 1043*. Special Session 2020-4.

<https://www.ncleg.gov/Sessions/2019/Bills/House/PDF/H1043v7.pdf>

<sup>152</sup> Office of North Dakota Governor Doug Burgum. (2020, May 12). *Emergency Commission approves using over \$500M in federal funds for COVID-19 response and recovery*. State of North Dakota.

<https://www.governor.nd.gov/news/emergency-commission-approves-using-over-500m-federal-funds-covid-19-response-and-recovery>

<sup>153</sup> Office of Puerto Rico Governor Wanda Vázquez Garced. (2020, May 14). *Governor Vazquez Garced announces plan for the disbursement of the \$2.2 billion granted to Puerto Rico by the CARES Act*. Territory of Puerto Rico. <https://www.fortaleza.pr.gov/content/gobernadora-v-zquez-garced-anuncia-plan-para-el-desembolso-de-los-22-mil-millones-otorgados>

<sup>154</sup> South Carolina Office of Regulatory Staff. (2020). *Coronavirus Aid, Relief, and Economic Security or “CARES Act.”* State of South Carolina. <https://ors.sc.gov/broadband/coronavirus-aid-relief-and-economic-security-or-cares-act>

<sup>155</sup> Office of South Dakota Governor Kristi Noem. (2020, October 27). *Governor Noem Announces K-12 Connect*. State of South Dakota. <https://news.sd.gov/newsitem.aspx?id=27423>

<sup>156</sup> Office of Tennessee Governor Bill Lee. (2020, August 21). *Gov. Lee Announces \$61 Million in Emergency Broadband Grants*. State of Tennessee. <https://www.tn.gov/governor/news/2020/8/21/gov-lee-announces-61-million-in-emergency-broadband-grants.html>

<sup>157</sup> General Assembly of the State of Vermont. (2020) *H.966: An act relating to COVID-19 funding and assistance for broadband connectivity, housing, and economic relief*. State of Vermont.

<https://legislature.vermont.gov/Documents/2020/Docs/BILLS/H-0966/H-0966%20As%20Passed%20by%20Both%20House%20and%20Senate%20Unofficial.pdf>

## Governor Strategies to Expand Affordable Broadband Access

---

<sup>158</sup> Office of Virginia Governor Ralph Northam. (October 2020). *Governor Northam Allocates \$30 Million in CARES Act Funding to Fast-Track Broadband Projects*. Commonwealth of Virginia.

<https://www.governor.virginia.gov/newsroom/all-releases/2020/october/headline-860746-en.html>

<sup>159</sup> Office of West Virginia Governor Jim Justice. (2020). *CARES ACT Funding Allocation*. State of West Virginia. <https://governor.wv.gov/Pages/CARES-Act-Funding-Allocation.aspx>

<sup>160</sup> Office of Wyoming Governor Mark Gordon. (2020, August 14). *Gov. Gordon and Business Council use CARES Act to expand broadband to address COVID-19 impacts*. Wyoming Business Council.

<https://wyomingbusiness.org/news/gov-gordon-and-business-council-use-/12056>

- 
- i Federal Communications Commission, Fact Sheet: FCC Chairman: More Competition Needed in a High-Speed Broadband Market 1 (2014), [https://apps.fcc.gov/edocs\\_public/attachmatch/DOC-329160A1.pdf](https://apps.fcc.gov/edocs_public/attachmatch/DOC-329160A1.pdf).
- ii Allan Holmes and Chris Zubak-Skees, *U.S. Internet Users Pay More and Have Fewer Choices than Europeans*, Center for Public Integrity (Apr. 1, 2015), <http://www.publicintegrity.org/2015/04/01/16998/us-internet-users-pay-more-and-havefewer-choices-europeans>.
- iii *Id.*
- iv *Id.*
- v Jon Brodtkin, *One Big Reason We Lack Internet Competition: Starting an ISP is Really Hard*, ARS Technica (Apr. 6, 2014), <http://arstechnica.com/business/2014/04/one-big-reason-welack-internet-competition-starting-an-isp-is-really-hard/>. The FCC found that installation costs were the largest cost element to deploying broadband via fiber. U.S. Dept. of Transp., Fed. Highway Admin., Office of Policy and Governmental Affairs, Executive Order: Accelerating Broadband Infrastructure Development 16 (2012), <http://www.fhwa.dot.gov/policy/otps/workplan.pdf>. The percentage cost of conduit as compared to the excavation project itself is only 0.1% to 4.3%. Gigabit Communities: Technical Strategies for Facilitating Public or Private Broadband Construction in Your Community, <http://www.ctcnet.us/wp-content/uploads/2014/01/GigabitCommunities.pdf>
- vi Eshoo, Walden Introduce “Dig Once” Broadband Deployment Bill, Eshoo.House.Gov (Oct. 22, 2015), <https://eshoo.house.gov/issues/economy/eshoo-walden-introduce-Dig-Oncebroadband-deployment-bill/>.
- vii See U.S. Gov’t Accountability Off., GAO-12-168R, Broadband Conduit Deployment 5 (2012), <http://www.gao.gov/assets/600/591928.pdf>; San Francisco, Cal., Ordinance 220-14 (Oct. 6, 2014) (codified in various provisions of the S.F. Public Works Code), <http://www.sfbos.org/ftp/uploadedfiles/bdsupvrs/ordinances14/o0220-14.pdf>. In addition, the Utah Department of Transportation estimated cost savings of 15.5% per mile when conduit and fiber are installed at the time a road is being constructed versus installing the conduit and fiber at a later time. U.S. Gov’t Accountability Off., GAO-12-168R, Broadband Conduit Deployment 5 (2012), <http://www.gao.gov/assets/600/591928.pdf>. It is worth noting that the cost savings here are largely due to no longer having to re-excavate; laying conduit is enough to reap the benefits of the cost savings, as stringing the fiber generally does not require re-excavation. *Id.*
- viii *Id.*
- ix U.S. Gov’t Accountability Off., GAO-12-168R, Broadband Conduit Deployment 5 (2012), <http://www.gao.gov/assets/600/591928.pdf>.
- x See, e.g., Cal. Gov’t Code § 4216.2(a)(1); Ga. Code Ann. § 25-9-6(a); 220 Ill. Comp. Stat. 50/4; Kan. Stat. Ann. § 66-1804(a); Mo. Rev. Stat. § 319.026; Or. Admin. R. § 952-001- 0050; Tex. Util. Code Ann. § 251.151(a).
- xi CommScope, Broadband Applications and Construction Manual 8.2 (2014) [http://www.commscope.com/Docs/Fiber\\_Optics\\_Const\\_Manual\\_CO-107147.pdf](http://www.commscope.com/Docs/Fiber_Optics_Const_Manual_CO-107147.pdf) (“high consideration” is given to locates marks when determining excavation damages).
- xii U.S. Gov’t Accountability Off., GAO-12-168R, Broadband Conduit Deployment (2012), <http://www.gao.gov/assets/600/591928.pdf>.
- xiii See, e.g., Mass. Gen. Laws ch. 81, § 21 (“No state highway shall be dug up ... without written permit of the department ...”); 605 Ill. Comp. Stat. 5/9-113 (“No ... equipment of any public utility company, municipal corporation or other public or private corporation, association, or person shall be located ... under or along any highway, or upon any township or district road, without first obtaining written consent of the appropriate highway authority...”).
- xiv California Environmental Quality Act, Cal. Pub. Res. Code § 21000 et seq. This statute, and others like it, requires an in-depth environmental impact report for all activities for which private entities receive a government-issued permit.



- 
- xv U.S. Gov't Accountability Off., GAO-12-168R, Broadband Conduit Deployment 6 (2012), <http://www.gao.gov/assets/600/591928.pdf>.
- xvi *Id.* at 5.
- xvii Cf. Edison Electric Institute, Out of Sight, Out of Mind 2012: An Updated Study on the Undergrounding of Overhead Power Lines (2012), <http://www.eei.org/issuesandpolicy/electricreliability/undergrounding/documents/undergroundreport.pdf>
- xviii *Id.* at 25.
- xix Edison Electric Institute, Out of Sight, Out of Mind 2012: An Updated Study on the Undergrounding of Overhead Power Lines 5 (2012), <http://www.eei.org/issuesandpolicy/electricreliability/undergrounding/documents/undergroundreport.pdf>
- xx See Jason Koebler, *The 21 Laws States Use to Crush Broadband Competition*, Motherboard (Jan. 14, 2015), <http://motherboard.vice.com/read/the-21-laws-states-use-to-crushbroadband-competition>.
- xxi Dig Once ideas—including Dig Smart—tend to be politically popular, supported by Democrats and Republicans. The federal Dig Once House bill, sponsored by Rep. Eshoo (DCalif.) and Rep. Walden (R-Or.), received praise from both sides of the aisle, along with endorsements from FCC Commissioners Rosenworcel (a Democrat) and Pai (a Republican). See Moriah, Mensah, “*Dig Once*” Could Lead to Smarter Broadband, R Street (Jan. 14, 2016), <http://www.rstreet.org/2016/01/14/dig-once-could-lead-to-smarter-broadband/>. See also Amir Nasr, *Widely Supported ‘Dig Once’ Bill Faces Procedural Hurdles*, Morning Consult (Nov. 18, 2015), <http://morningconsult.com/2015/11/widely-supported-dig-oncebill-faces-procedural-hurdles/>; Alisha Green, *Bipartisan “Dig Once” Legislation Provides Hope for Broadband Expansion*, Government Technology (Nov. 2, 2015), <http://www.govtech.com/network/Bipartisan-Dig-Once-Legislation-Provides-Hope-forBroadband-Expansion.html> (“At least one issue on Capitol Hill brings together Republicans, Democrats, the tech industry, and the White House: legislation to expand high-speed Internet access nationwide, especially for rural, tribal, and other remote areas.”).
- xxii U.S. Dept. of Transp., Fed. Highway Admin., Office of Policy and Governmental Affairs, Executive Order: Accelerating Broadband Infrastructure Development 16 (2012), <http://www.fhwa.dot.gov/policy/otps/workplan.pdf> (“[T]he largest cost element for deploying broadband via fiber optic cable is the cost of placement, such as burying the fiber in the ground, rather than the cost of the fiber itself.”).
- xxiii Data from discussions with BHC Rhodes, civil engineering firm: <http://ibhc.com/>
- xxiv *Gigabit Community: Technical Strategies for Facilitating Public or Private Broadband Construction in Your Community*, <http://www.ctcnet.us/blog/gigabit-communities-how-localgovernments-can-facilitate-private-investment-in-new-gigabit-networks/>.
- xxv Data from discussions with BHC Rhodes, civil engineering firm: <http://ibhc.com/>
- xxvi Data from discussions with BHC Rhodes, civil engineering firm: <http://ibhc.com/>
- xxvii This is not meant to be an exact number on how much installation of conduit would cost, but rather, an approximation, with an illustration on how such a policy could be profitable over time.
- xxviii See Minn. Stat. § 237.90; Fla. Stat. § 364.0135.
- xxix See, e.g., Santa Monica, Cal., Mun. Code, § 7.06.300(b); Minn. Stat. § 161.462.
- xxx See, e.g., 30-092 Vt. Code R. § 8091; Ocala, Florida, Mun. Code, § 58.136.
- xxxi See, e.g., Los Angeles Department of Public Works, Joint Trench Utility Permit Guidelines (2015), <http://dpw.lacounty.gov/general/forms/download/2175.pdf>.
- xxxii See Houston, Texas, Mun. Code, § 40-145.